



XENIOS®
GLOBAL-FITNESS.ES *USA*

FUNCTIONAL



WORKBOOK 01/2015



EQUIPMENT FOR THE FITTEST,

This is our goal! Xenios USA® is a company focus on development, production and marketing of professional workout tools for those who like to play with the Sport of Fitness: Crossfit®, Functional Training, Weight Lifting, Power Lifting, Strength and Conditioning are just some of field our products are employed in.

The road to the fittest is made of heavy duty workouts and so the equipment needs to be able to bear such kind of severe training sessions.

Xenios USA® was born on 2009, gathering all the ideas, training methods, trends, and new ways of the worldwide workout markets: learning from the legacy of gym training and surfing the new wave of the Functional Training and Performance Training methods. Xenios USA® hired a team of experienced master trainers, biomechanical engineers, product managers, and marketing managers in order to build and then keep updated a full range of products that could really match the new workout trends.

Xenios USA® products were originally developed, and so they keep being developed, by a joint venture team of American and Italian product designers.

The Xenios USA® main mission is headed to provide as more as possible reliable tools to those who need to really stress them without having to fight with faults and breakages of the equipment.

All Xenios USA® products are drawn, tested and then manufactured by Xenios USA®. The process to let an idea come true, is strictly ruled by highest standards of product quality. Each mass production batch is made under a close quality control and all products that can't match the Xenios USA® requirements are rejected.

All raw materials and production processes, like steel welding and bending or steel coating are made according to the Xenios USA® data sheets and most of the times they need to match over-the-standard parameters.

Most of the Xenios USA® products are furthermore tested and certified by experts of products safety, like, for example the TUV-SUD® that was chosen to test all the XRIG™ products.

At Xenios USA® we believe in the future of the Sport of Fitness: we believe most of people will sooner or later approach the Functional Training classes, falling in love with the incredible performance goals that can be achieved. That is the reason we keep investing all of our time and efforts by the research and development of new training tools able to satisfy from time to time new Coaches' needs.

We are proud to have been chosen by many Affiliate Owners as their equipment source and we are furthermore proud to equip some of the most famous Throw Down Contest. Both help us to learn either from the daily use of our products and from their behavior while stressed by professional athletes. Our challenge keep going on day by day.

Stay tuned with us and the Sport of Fitness!

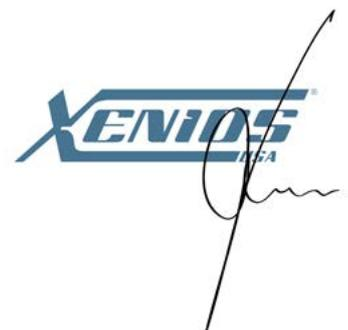

CrossFit® is a registered trademark of Crossfit Inc.(USA). The Xenios USA company and registered trademarks are not affiliated and/or associated with and/or endorsed and/or sponsored by Crossfit Inc. The Xenios USA products and services are not endorsed, tested, sponsored by and/or associated with Crossfit Inc. and/or with any of the registered trademarks, products and services of Crossfit Inc.



MORE THAN A WORKOUT TOOL

At Xenios USA® we couldn't consider our mission accomplished by just developing and manufacturing high-end workout tools. Since we operate within a brand-new kind of sport market, we have thought to those who are new to these markets as well, and so those who need to be supported at the beginning, or, even all along their path. Xenios USA® consultant services were thought as a value-added of Xenios USA® products and they can be purchased either as an add-on for a first installation order, or while an Affiliate Box business is already running. Ask any further to the Xenios USA® Team.



R2B it stands for "Road to the Box". It is a kind of training course for those who are going to become an Affiliate owner or manager. Most of Coaches or Athletes who want to switch their sport passion in to a business opportunity, stuck at the entrance door of the business: how to set the business up? What are the main rules to be followed? How to draft a business plan to know when I will start earning? How to lay down the equipment within the layout of the floor? What's the perfect list of equipment I may need? What else? Am I sure to be ready to organize and to schedule the classes? These are just some of the questions we are going to answer at, thru the R2B program. R2B is a program developed and managed by an experienced team of Coaches and Box owners outsourced by Xenios USA.*



XENIOS USA ACADEMY the Academy of Xenios USA® was born as a kind of container of specialty workshops held by professional coaches. The Academy doesn't aim to be a school or a certified workout method, but just a gateway for coaches and athletes, to participate to workshops thought to deepen several workout subjects and aspects: Weightlifting and Powerlifting techniques, Kettlebell training, Clubbell® training, mobility and rehab, advanced gymnastic movements, are just some of the topics the Xenios USA® Academy seminars will carry on. The Xenios USA® Academy calendar and team of coaches may change from Country to Country and all the seminars' venues are selected just among the full-equipped Xenios USA® Flagship Workout sites. Stay tuned with our social media to keep being informed about dates to be saved!



BOX BUILDING When an Affiliate Box is about to be set-up, one of the heaviest lorry to bear for the new owner is just the first installation of all the purchased workout tools, stations and facility outfitting. At Xenios USA® we have built a team of experienced workers that could be hired by our clients in order to provide them a ground-up installation. By purchasing the "Box Building" service (where available), the Xenios USA's clients could be assisted on items unpacking, floor laying, Rig and Rack mounting and more, up to the rubbish collection and disposal while all job will be done. The "Box Building" could be purchased as an add-on of a Xenios USA® full-equipped Box order and prices may vary according to the several options the customers could tick in or out.



FLAGSHIP BOX at Xenios USA® we believe that those who really want to trust our brand and products, need to have the chance to be more than a client. So we have thought to the Xenios USA® Flagship contract: if you really intend to full-equip your Box with all Xenios USA® gear, from ground up, we can provide you a special package, made of products, services and advantages, that we use to call "really all-inclusive". The whole lay-out of your Affiliate will be thought and drawn by our designers and it will be fully decorated with our brand image. Flagships will be just few per each Country. They will need to match some facility requirements and they will be a kind of special team of Boxes where new items will be tested, or where workshops of the Xenios USA Academy will be held, or where tools will be always kept updated. The Xenios USA® Flagship program was thought to offer our best to those who really want to be Xenios USA®.

Attention: some of the above services may not be available within some Countries.



FLAGSHIP BOX at Xenios USA® we believe that those who really want to trust our brand and products, need to have the chance to be more than a client. So we have thought to the Xenios USA® Flagship contract: if you really intend to full-equip your Box with all Xenios USA® gear, from ground up, we can provide you a special package, made of products, services and advantages, that we use to call "really all-inclusive". The whole lay-out of your Affiliate will be thought and drawn by our designers and it will be fully decorated with our brand image. Flagships will be just few per each Country. They will need to match some facility requirements and they will be a kind of special team of Boxes where new items will be tested, or where workshops of the Xenios USA Academy will be held, or where tools will be always kept updated. The Xenios USA® Flagship program was thought to offer our best to those who really want to be Xenios USA®. Attention: some of the above services may not be available within some Countries.

FLAGSHIP PROGRAM



WE REALLY CONCERN ABOUT SAFETY

At Xenios USA® we believe that a good and powerful marketing is not the only way to let a workout tool be really trustable, durable and safe. A serious and as longer as possible products' warranty chart is one more evidence to let clients believe, but it is not yet the ultimate key-point. At Xenios USA® we develop and draw our products by ourselves, we always work by prototypes that need to be tested in order to confirm that an idea can be really come true and so goes in to a mass-manufacturing process. We seriously control the quality of the production processes and the finished goods, by rejecting all items that can't match our high quality requirements. We care about packaging and carrying. We listen to all after-sales claims and we take all clients reports in serious consideration: customers' feed-back is the best way to make all products fitting the true needs of those who buy and use them.

So, what else? The Certifications: at Xenios USA® we like to overstress our products and we also like to let professionals of products' safety to do it. We like our quality to be also tested by third-parts. Furthermore, we do not just follow the rules about products' safety. We like to go beyond in testing, and to be able to give to our clients a really safe and severe tested range of products. A tested and certified product is not just a good purchase that could last as longer as possible, or bear severe workouts. A tested product can be also a kind of insurance for those who are going to be an owner or a manager of an Affiliate, a Gym, a Training Center. Headache-less products could be the right way to offer to members a safe workout environment.



TUV-SUD: most of our products (such as benches, racks, Crossfit® stations etc..) are tested and certified by the TUV-SUD®, that is one of the worldwide most affordable product testing company. All products are tested in order to comply with the latest products safety regulations (E.G: in Europe the EN-ISO 20957-1, EN-ISO 957-2 and EN-ISO 957-4)*. All along the catalogue we have mentioned which products are tested according to TUV-SUD® safety specs.

We furthermore care about the safety of the electronic products we carry. Either for the Xenios USA® items and for any third-brand product, we make sure they feature all needed certification, such as, for example, the CE and the ROHS ones*.

In order to make really reliable products, we also concern about safety and quality certifications of raw materials (such as, for example, the steel tubes used to make the whole XRIG™ range of items), painting and coating materials and processes, hardware, welding process and welder's certified skills. A product making process involve dozens of matters, from raw materials selection up to the packaging of the

finished goods, and our R&D and Product Team is just formed by experienced technicians and engineers that can let us be proud to label a workout tool with our logo.

**Some of the mentioned products' safety regulations and/or safety marks may not be valid for some Countries.*

CrossFit® is a registered trademark of Crossfit Inc.(USA). The Xenios USA company and registered trademarks are not affiliated and/or associated with and/or endorsed and/or sponsored by Crossfit Inc. The Xenios USA products and services are not endorsed, tested, sponsored by and/or associated with Crossfit Inc. and/or with any of the registered trademarks, products and services of Crossfit Inc.



At Xenios USA® we have thought to those who really need to face severe workout. The Magnum™ series was born as a kind of next-level version of some of the items commonly employed within heavy duty WOD.

Our R&D team has oversized some of our tools in order to switch them in to a tank-like series. Any of those products is headed to the Strongmen or to the Boxes where big guys are working out. Magnum™ products are almost unbreakable.

At Xenios USA® we have thought to the best way to let some products be also manufactured following a kind of next-level bill of specifications. There are some workout tools, such as the Squat Stand, or the Yoke and Sled, or the Utility Flat Bench, or many parts and pre-set configurations of the XRIG™ series, that may be employed to bear tough workouts or quite heavy body-weights, such as the ones of the Strongmen. Due to those reasons, all mentioned items have been also drawn bigger and stronger: they have been drawn in order to comply with the serious overloading tests performed on to all the products that aim to belong to the MAGNUM™ series. All products made to belong to the MAGNUM™ series are made with an industrial grade of steel tubes. All square

steel tubes are bigger in size - switched from the standard 6x6 cm. to the oversized 8x8 cm. - and in thickness – switched from the standard 10 Gauge (3 mm.) or 11 Gauge (3.5 mm) to the oversized 8 Gauge (4.2 mm.).

All MAGNUM™ series products are welded by using a special certified kind of welding-robots, commonly involved with the construction of industrial machines like big cranes.

All Steel plates and sheets used to manufacture the MAGNUM™ products are thicker than the standard ones. Furthermore, the MAGNUM™ products are tested in order to bear heavier weights: three times higher than their “younger” brothers. E.G.: a Magnum Squat Stand is tested to bear up to 1500 Kg. so we can say it is almost unbreakable.

Xenios USA®

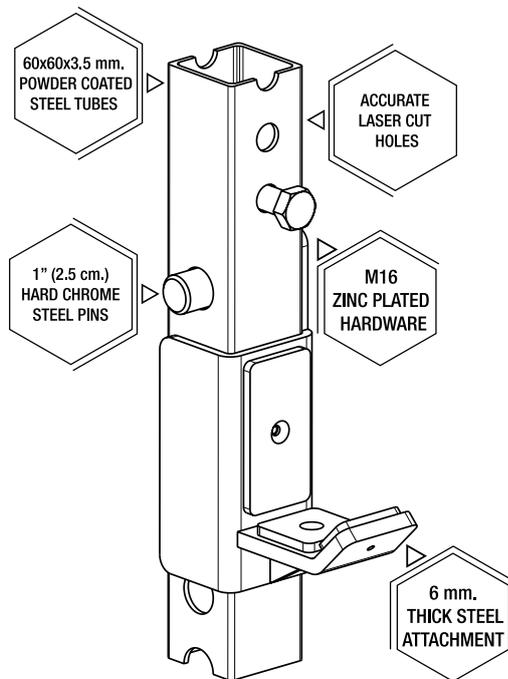

Xenios USA®

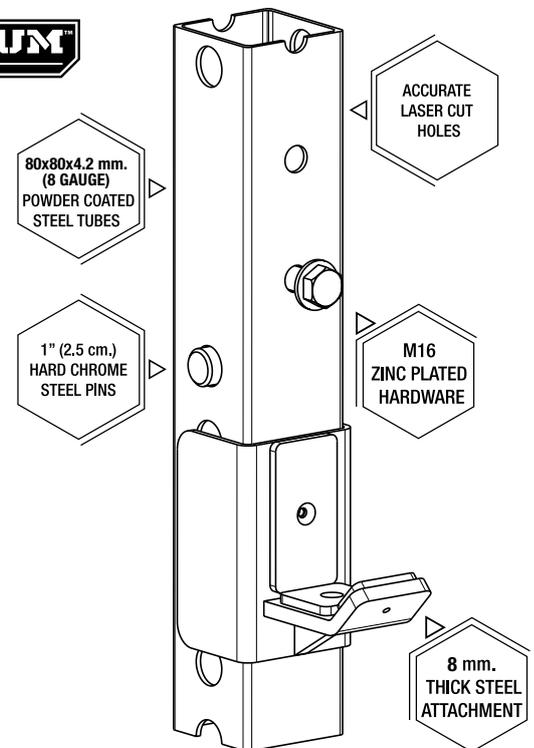

All MAGNUM™ products parts are made by using industrial grade steel tubes so to really be ready to bear “oversized” workouts. The steel used to make the MAGNUM™ tubes is normally employed in industrial machine constructions, such as the building cranes. All square tubes are 8x8 cm. sized and 4.2 mm. thickness (8 Gauges), while all the round tubes are 32 mm. diameter by 4 mm. thickness. All steel plates and brackets are made using no-lower than 8 mm. thickness steel sheets. All main steel parts are bolted together just by using M16 bolts, coupled with M16 self-locking nuts: up to 300 Nm in tightening strength. All bolts feature safety pvc end-caps so to avoid any chance of injury with the offset of the same bolts out of the nuts after being tightened. All hardware is zinc plated so to be rust-proof.



FUNCTIONAL INDEX

WEIGHT PLATES

Pg. 9



GYMNASTIC AND BODYWEIGHT GEAR

Pg. 65



DUMBBELLS

Pg. 12



UNCONVENTIONAL GEAR

Pg. 78



BARS

Pg. 16



WEIGHT AND POWER LIFTING

Pg. 83



BARS ACCESSORIES

Pg. 25



STRONGMEN GEAR

Pg. 89



KETTLEBELLS

Pg. 30



CARDIO ENDURANCE

Pg. 97



TACFIT® CLUBBELLS®

Pg. 34



FIGHTER GEAR

Pg. 100



TRAINING BAGS

Pg. 35



WORKOUT GEAR

Pg. 101



TRAINING BALLS

Pg. 37



RE-HAB AND MOBILITY

Pg. 106



TRAINING ROPES

Pg. 44



FACILITY OUTFITTING

Pg. 115



TRAINING SLEDS

Pg. 48



XRIG™ STATIONS

Pg. 125



PLYOMETRIC GEAR

Pg. 55



XRIG™ - PARTS AND OPTIONS

Pg. 147



ACCELERATION AND AGILITY GEAR

Pg. 58



#TO BE XENIOS USA

Pg. 174

JUMP ROPES

Pg. 64



Some of the products of this catalogue may not be available within some Countries. Ask to the Xenios USA Team in order to know exactly what are the workout tools that can be purchased within each Country.





WEIGHT PLATES



COMPETITION BUMPER PLATE

- PSBPCRBPL5 White Rubber Competition Bumper Plate w/stainless steel inner plate - 5 Kg.

- PSBPCRBPL10 Green Rubber Competition Bumper Plate w/stainless steel inner plate - 10 Kg.

- PSBPCRBPL15 Yellow Rubber Competition Bumper Plate w/stainless steel inner plate - 15 Kg.

- PSBPCRBPL20 Blue Rubber Competition Bumper Plate w/stainless steel inner plate - 20 Kg.

- PSBPCRBPL25 Red Rubber Competition Bumper Plate w/stainless steel inner plate- 25 Kg.

△ 10.000 UNBROKEN DROPS TESTED



CONTEST BUMPER PLATES

- PSBPRBPL5 Light Grey Rubber Contest Bumper Plate w/stainless steel inner ring - 5 Kg.

- PSBPRBPL10 Green Rubber Contest Bumper Plate w/stainless steel inner ring - 10 Kg.

- PSBPRBPL15 Yellow Rubber Contest Bumper Plate w/stainless steel inner ring - 15 Kg.

- PSBPRBPL20 Blue Rubber Contest Bumper Plate w/stainless steel inner ring - 20 Kg.

- PSBPRBPL25 Red Rubber Contest Bumper Plate w/stainless steel inner ring - 25 Kg.

△ 8.000 UNBROKEN DROPS TESTED



TRAINING BUMPER PLATES

- XSBPRBPL5 Black Rubber Training Bumper Plate w/stainless steel inner ring - 5 Kg.

- XSBPRBPL10 Black Rubber Training Bumper Plate w/stainless steel inner ring - 10 Kg.

- XSBPRBPL15 Black Rubber Training Bumper Plate w/stainless steel inner ring - 15 Kg.

- XSBPRBPL20 Black Rubber Training Bumper Plate w/stainless steel inner ring - 20 Kg.

- XSBPRBPL25 Black Rubber Training Bumper Plate w/stainless steel inner ring - 25 Kg.

△ 5.000 UNBROKEN DROPS TESTED

EXTRA HARDNESS ON 5 KG.: > 92°

*1 BUMPER PLATES Limited Warranty covers just plates breakages.

2 Year: COMPETITION, CONTEST and HEAVY DUTY Bumper Plates (all sizes but 5 Kg.) when used on to a professional weightlifting platform (such as the Xenios USA® one) or equivalent kind of flooring.

1 Year: COMPETITION, CONTEST, HEAVY DUTY Bumper Plates (5 Kg. variant), and TRAINING Bumper Plates (all sizes but 5 Kg.) when used on to a professional weightlifting platform (such as the Xenios USA® one) or equivalent kind of flooring.

6 Month: COMPETITION, CONTEST, HEAVY DUTY Bumper Plates (all sizes), and TRAINING Bumper Plates (all sizes but 5 Kg.), when used on to any other kind of rubber flooring. TRAINING Bumper Plates (5 Kg. variant). All kind and size of Bumper Plates against inner steel ring loosening and/or breakage.

No Warranty: all kind and size of Bumper Plates used on to not-rubber coated floorings. For any further about Xenios USA® products' warranty, please refer to the Xenios USA® Warranty Chart, available at www.xeniosusa.com



WEIGHT PLATES



HEAVY DUTY BUMPER PLATES

▲ 15.000 UNBROKEN DROPS TESTED

XSBPRBPLS5 Black Rubber Heavy Duty Bumper Plates - 5 Kg.

SBR GRANULATE

XSBPRBPLS10 Black Rubber Heavy Duty Bumper Plates - 10 Kg.

XSBPRBPLS15 Black Rubber Heavy Duty Bumper Plates - 15 Kg.

XSBPRBPLS20 Black Rubber Heavy Duty Bumper Plates - 20 Kg.

UP TO 20 Db. LESS
WHEN DROPPED

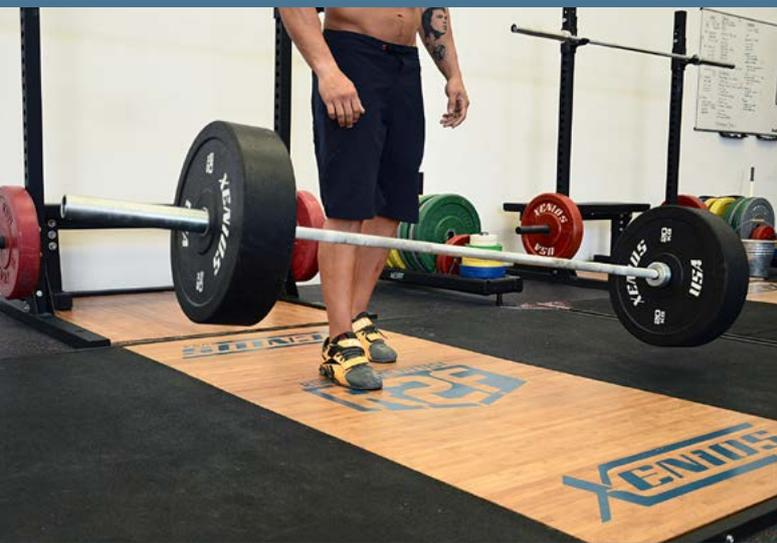

TECHNIQUE PLATES

XSTCPL01 PE Technique Plate - 2.5 kg.



FRACTIONAL PLATES

XSSTFRPL0.125 Black Mini-Rubber Bumper Plate - 0.125 Kg.

XSSTFRPL0.25 Grey Mini-Rubber Bumper Plate - 0.25 Kg.

XSSTFRPL0.5 White Mini-Rubber Bumper Plate - 0.5 Kg.

XSSTFRPL1 Green Mini-Rubber Bumper Plate - 1 Kg.

XSSTFRPL1.5 Yellow Mini-Rubber Bumper Plate - 1.5 Kg.

XSSTFRPL2 Blue Mini-Rubber Bumper Plate - 2 Kg.

XSSTFRPL2.5 Red Mini-Rubber Bumper Plate - 2.5 Kg.



*1 BUMPER PLATES Limited Warranty covers just plates breakages.

2 Year: COMPETITION, CONTEST and HEAVY DUTY Bumper Plates (all sizes but 5 Kg.) when used on to a professional weightlifting platform (such as the Xenios USA® one) or equivalent kind of flooring.

1 Year: COMPETITION, CONTEST, HEAVY DUTY Bumper Plates (5 Kg. variant), and TRAINING Bumper Plates (all sizes but 5 Kg.) when used on to a professional weightlifting platform (such as the Xenios USA® one) or equivalent kind of flooring.

6 Month: COMPETITION, CONTEST, HEAVY DUTY Bumper Plates (all sizes), and TRAINING Bumper Plates (all sizes but 5 Kg.), when used on to any other kind of rubber flooring. TRAINING Bumper Plates (5 Kg. variant). All kind and size of Bumper Plates against inner steel ring loosening and/or breakage.

No Warranty: all kind and size of Bumper Plates used on to not-rubber coated floorings. For any further about Xenios USA® products' warranty, please refer to the Xenios USA® Warranty Chart, available at www.xeniosusa.com



WEIGHT PLATES

PLATES RACKS

RKPL01 Spider Plates Rack- 6 sleeves

WEIGHT (Kg./Lbs)	L (cm.)	W (cm.)	H (cm.)
41.5 / 91.5	94	94	106

- N° Plates support: 6 - Color: Matte Black
- Max. load: 1200 kg.
- Steel tubes thickness: 3 mm.

⚠ Plates are not included



RKBMPL01 Bumper Plates Trolley - 8 slugs

WEIGHT (Kg./Lbs)	L (cm.)	W (cm.)	H (cm.)
25 / 55	142	42	76

- N° Plates support: 1 PC to 19 PCs - Color: Matte Black
- Max. load: 500 kg.
- Steel tubes thickness: 2.5 mm.

⚠ Plates are not included

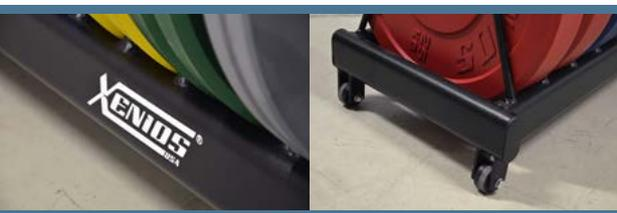

RKBMPL03 Bumper Plates Stacker w/wheels

WEIGHT (Kg./Lbs)	L (cm.)	W (cm.)	H (cm.)
15 / 33	45	45	100

- N° Plates support: 25 PCs (5 Kg. plates) - Color: Matte Black
- Max. load: 300 kg.

⚠ Plates are not included

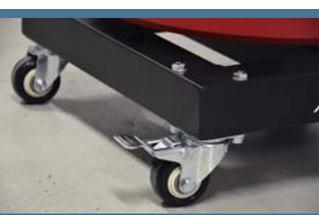

DUMBBELLS

RUBBER OCTAGONAL DUMBBELLS

ORBDB1	Black Rubber Octagonal Dumbbell w/ contoured handle - 1 Kg.
ORBDB2	Black Rubber Octagonal Dumbbell w/ contoured handle - 2 Kg.
ORBDB3	Black Rubber Octagonal Dumbbell w/ contoured handle - 3 Kg.
ORBDB4	Black Rubber Octagonal Dumbbell w/ contoured handle - 4 Kg.
ORBDB5	Black Rubber Octagonal Dumbbell w/ contoured handle - 5 Kg.
ORBDB6	Black Rubber Octagonal Dumbbell w/ contoured handle - 6 Kg.
ORBDB7	Black Rubber Octagonal Dumbbell w/ contoured handle - 7 Kg.
ORBDB8	Black Rubber Octagonal Dumbbell w/ contoured handle - 8 Kg.
ORBDB9	Black Rubber Octagonal Dumbbell w/ contoured handle - 9 Kg.
ORBDB10	Black Rubber Octagonal Dumbbell w/ contoured handle - 10 Kg.
ORBDB12.5	Black Rubber Octagonal Dumbbell w/ contoured handle - 12.5 Kg.
ORBDB15	Black Rubber Octagonal Dumbbell w/ contoured handle - 15 Kg.
ORBDB17.5	Black Rubber Octagonal Dumbbell w/ contoured handle - 17.5 Kg.
ORBDB20	Black Rubber Octagonal Dumbbell w/ contoured handle - 20 Kg.
ORBDB22.5	Black Rubber Octagonal Dumbbell w/ contoured handle - 22.5 Kg.
ORBDB25	Black Rubber Octagonal Dumbbell w/ contoured handle - 25 Kg.
ORBDB27.5	Black Rubber Octagonal Dumbbell w/ contoured handle - 27.5 Kg.
ORBDB30	Black Rubber Octagonal Dumbbell w/ contoured handle - 30 Kg.
ORBDB32.5	Black Rubber Octagonal Dumbbell w/ contoured handle - 32.5 Kg.
ORBDB35	Black Rubber Octagonal Dumbbell w/ contoured handle - 35 Kg.
ORBDB37.5	Black Rubber Octagonal Dumbbell w/ contoured handle - 37.5 Kg.
ORBDB40	Black Rubber Octagonal Dumbbell w/ contoured handle - 40 Kg.
ORBDB42.5	Black Rubber Octagonal Dumbbell w/ contoured handle - 42.5 Kg.
ORBDB45	Black Rubber Octagonal Dumbbell w/ contoured handle - 45 Kg.
ORBDB47.5	Black Rubber Octagonal Dumbbell w/ contoured handle - 47.5 Kg.
ORBDB50	Black Rubber Octagonal Dumbbell w/ contoured handle - 50 Kg.

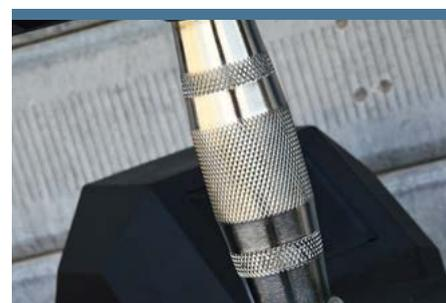

DUMBBELLS

FULL RUBBER HEX-DUMBBELLS

XSORBDB12.5	Black Full Rubber HEX Dumbbell w/ contoured handle - 12,5 Kg.
XSORBDB15	Black Full Rubber HEX Dumbbell w/ contoured handle - 15 Kg.
XSORBDB17.5	Black Full Rubber HEX Dumbbell w/ contoured handle - 17,5 Kg.
XSORBDB20	Black Full Rubber HEX Dumbbell w/ contoured handle - 20 Kg.
XSORBDB22.5	Black Full Rubber HEX Dumbbell w/ contoured handle - 22,5 Kg.
XSORBDB25	Black Full Rubber HEX Dumbbell w/ contoured handle - 25 Kg.
XSORBDB27.5	Black Full Rubber HEX Dumbbell w/ contoured handle - 27,5 Kg.
XSORBDB30	Black Full Rubber HEX Dumbbell w/ contoured handle - 30 Kg.
XSORBDB32.5	Black Full Rubber HEX Dumbbell w/ contoured handle - 32,5 Kg.
XSORBDB35	Black Full Rubber HEX Dumbbell w/ contoured handle - 35 Kg.
XSORBDB37.5	Black Full Rubber HEX Dumbbell w/ contoured handle - 37,5 Kg.
XSORBDB40	Black Full Rubber HEX Dumbbell w/ contoured handle - 40 Kg.
XSORBDB42.5	Black Full Rubber HEX Dumbbell w/ contoured handle - 42,5 Kg.
XSORBDB45	Black Full Rubber HEX Dumbbell w/ contoured handle - 45 Kg.
XSORBDB47.5	Black Full Rubber HEX Dumbbell w/ contoured handle - 47,5 Kg.
XSORBDB50	Black Full Rubber HEX Dumbbell w/ contoured handle - 50 Kg.



OVERSIZE RUBBER HEX DUMBBELLS

HRBDB55	Strongman Black Rubber Hex Dumbbell w/ contoured handle - 55 Kg.
HRBDB60	Strongman Black Rubber Hex Dumbbell w/ contoured handle - 60 Kg.
HRBDB65	Strongman Black Rubber Hex Dumbbell w/ contoured handle - 65 Kg.
HRBDB70	Strongman Black Rubber Hex Dumbbell w/ contoured handle - 70 Kg.



DUMBBELLS

DUMBBELLS RACKS

RKMSVSTDB03 Massive Storage Rack - Multistorage Unit for: Dumbbells

- Massive Storage Rack - Side Upright w/wheels - x2PCs
- Massive Storage Rack - Dumbbells Tier - x3PCs

WEIGHT (Kg./Lbs)	L (cm.)	W (cm.)	H (cm.)
55 / 121	201	50	123

- Material: Powder coated steel - steel tube thickness = 3,5 mm
- Color: Matte black

⚠ * Fractional Plates and Loop Bands Storages are sold as an option





BARS



COMPETITION BARS

READY FOR OLYMPIC LIFTING



XSBOBAR01 PRO BEARING - 86" Man Olympic Bar

WEIGHT (Kg./Lbs)	L (cm.)
20 / 44	220

- 86" Hard Chrome plated 1665Mpa-Heat Treated-Spring Steel Man Olympic Bar w/8 bearings (4xdouble-case needle + 4xball) and dual snap ring closing system - 240.000+ PSI - 2000 Lbs max. load - 220 cm. - 28 mm. 20 Kg. - Olympic IWF & IPF marks w/o center mark

- ⚠ Equipped with special heavy duty needle bearings. Double thickness; Longer Needles; Self-Lubricating channel.
- ⚠ All Xenios USA® bars are not pre-equipped with collars.

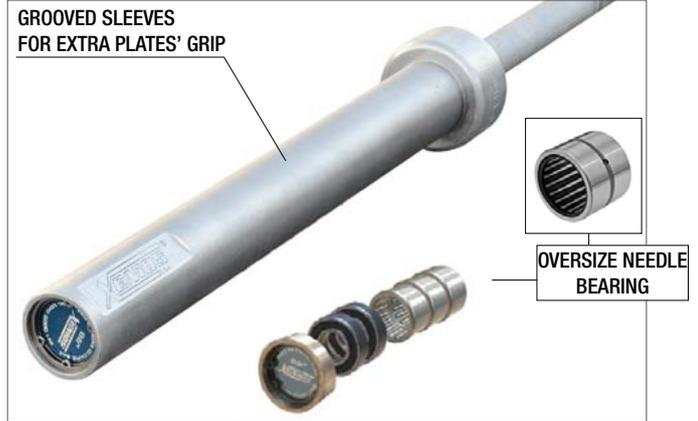

COMPETITION BARS

READY FOR OLYMPIC LIFTING



XSBOBAR02 ELITE BEARING - 86" Man Olympic Bar

WEIGHT (Kg./Lbs)	L (cm.)
20 / 44	220

- 86" Hard Chrome finished 1665Mpa-Heat-Treated-Spring Steel Man Olympic Bar w/6 bearings (2xdouble-case needle + 4xball) and dual snap ring closing system - 240.000+ PSI - 1500 Lbs max. load - 220 cm. - 28 mm. 20 Kg. - Olympic IWF & IPF marks w/o center mark

- ⚠ Equipped with special heavy duty needle bearings. Double thickness; Longer Needles; Self-Lubricating channel.
- ⚠ All Xenios USA® bars are not pre-equipped with collars.

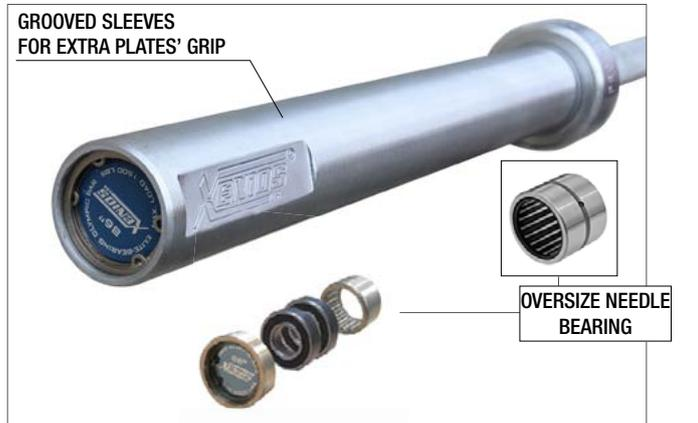

*1 COMPETITION AND PROFESSIONAL BARS Lifetime Warranty covers just bar's shaft breakages. Bar's shaft bents warranty is just 1 year time limited.

Bar's shaft breakages and/or bents warranty main terms: it is valid just when COMPETITION and/or PROFESSIONAL bars are used on a professional weightlifting platform (such as the Xenios USA® one) or equivalent kind of flooring, and loaded with the Xenios USA® rubber Bumper Plates or equivalent quality.

2 Year: on to all bar and sleeves construction parts.

1 Year: on to all bar and sleeves finishing. Rust due to proven missing maintenance and cleaning or misuse (e.g.: due to storage on to bare steel racks) is not covered under warranty.

All Warranties on COMPETITION and PROFESSIONAL bars are void in case of negligent or faulty use, alteration, maintenance, storage or handling by the user. Negligent or faulty use includes abusive dropping of the bar (i.e., dropping the bar on to a not proper floor (10 mm. thick rubber flooring and lower are considered not proper), a box, bench, spotter arms or pins in a power rack, excessive dropping with insufficient or damaged bumpers, or dropping with iron plates, and similar usage). For any further about Xenios USA® products' warranty, please refer to the Xenios USA® Warranty Chart, available at www.xeniosusa.com



BARS



PROFESSIONAL BARS



XSOBAR01 POWERLIFTING BAR - 86" Man Power Lifting Bar

WEIGHT (Kg./Lbs)	L (cm.)
20 / 44	220

- 86" Hard Chrome Plated 60Mn-Heat Treated-Spring Steel Man Power Lifting Bar w/ self lubricate oversize bronze bushings and dual snap ring closing system - 180.000+ PSI - 2000 Lbs max. load - 220 cm. - 29 mm. - 20 Kg. - IPF and Squat marks

⚠ All Xenios USA® bars are not pre-equipped with collars.

GROOVED SLEEVES FOR EXTRA PLATES' GRIP

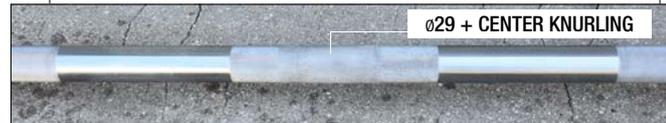
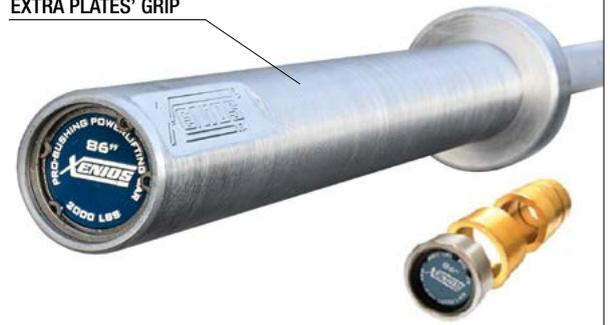

PROFESSIONAL BARS

READY FOR OLYMPIC LIFTING



XSOBAR10 PRO BUSHING BAR - 86" Man Olympic Bar

WEIGHT (Kg./Lbs)	L (cm.)
20 / 44	220

- 86" Bright Zinc plated "1665Mpa-Heat Treated-Spring Steel" Man Olympic Bar w/ oversize Sintered self-lubricated bronze bushings and Safe-Lock sleeve closing system - 240.000+ PSI - 1500 Lbs max. load 220 cm. - 28 mm. - 20 Kg. - Olympic IWF & IPF marks w/o center mark

⚠ All Xenios USA® bars are not pre-equipped with collars.

SEALED SLEEVES MAINTENANCE FREE

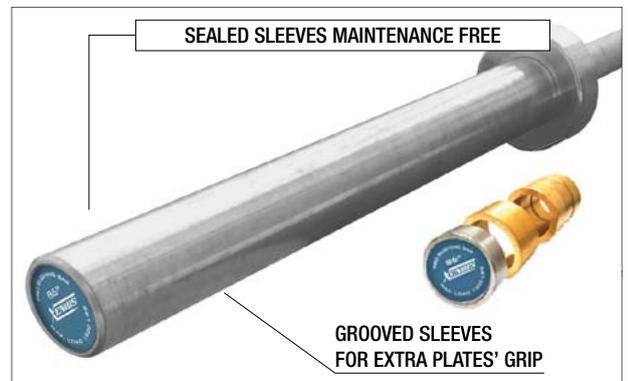

*1 COMPETITION AND PROFESSIONAL BARS Lifetime Warranty covers just bar's shaft breakages. Bar's shaft bents warranty is just 1 year time limited.

Bar's shaft breakages and/or bents warranty main terms: it is valid just when COMPETITION and/or PROFESSIONAL bars are used on a professional weightlifting platform (such as the Xenios USA® one) or equivalent kind of flooring, and loaded with the Xenios USA® rubber Bumper Plates or equivalent quality.

2 Year: on to all bar and sleeves construction parts.

1 Year: on to all bar and sleeves finishing. Rust due to proven missing maintenance and cleaning or misuse (e.g.: due to storage on to bare steel racks) is not covered under warranty.

All Warranties on COMPETITION and PROFESSIONAL bars are void in case of negligent or faulty use, alteration, maintenance, storage or handling by the user. Negligent or faulty use includes abusive dropping of the bar (i.e., dropping the bar on to a not proper floor (10 mm. thick rubber flooring and lower are considered not proper), a box, bench, spotter arms or pins in a power rack, excessive dropping with insufficient or damaged bumpers, or dropping with iron plates, and similar usage). For any further about Xenios USA® products' warranty, please refer to the Xenios USA® Warranty Chart, available at www.xeniosusa.com



BARS



PROFESSIONAL BARS

READY FOR OLYMPIC LIFTING



XSOBAR02 ELITE BUSHING BAR - 86" Man Olympic Bar

WEIGHT (Kg./Lbs)	L (cm.)
20 / 44	220

- 86" Nickel-Phosphor plated 1665Mpa-Heat Treated-Spring Steel Man Olympic Bar w/ oversize self-lubricated bronze bushings and dual snap ring closing system - 240.000+ PSI - 1500 Lbs max. load 220 cm. - 28 mm. - 20 Kg. - Olympic IWF & IPF marks w/o center mark

⚠ All Xenios USA® bars are not pre-equipped with collars.

GROOVED SLEEVES FOR EXTRA PLATES' GRIP



PROFESSIONAL BARS

READY FOR OLYMPIC LIFTING



XSBOBAR06 PRO LADY'S BAR - 79" Woman Olympic Bar

WEIGHT (Kg./Lbs)	L (cm.)
15 / 33	201

- 79" Bright Zinc Plated - 60Mn-Heat Treated Spring Steel Woman Olympic Bar w/6 bearings (2xdouble-case needle + 4xballs) and dual snap ring closing system - 180.000+ PSI - 500 Lbs max. load - 201 cm. - 25 mm. - 15 Kg. - Olympic IWF & IPF marks w/o center mark

⚠ Equipped with special heavy duty needle bearings. Double thickness; Longer Needles; Self-Lubricating channel.

⚠ All Xenios USA® bars are not pre-equipped with collars.

GROOVED SLEEVES FOR EXTRA PLATES' GRIP

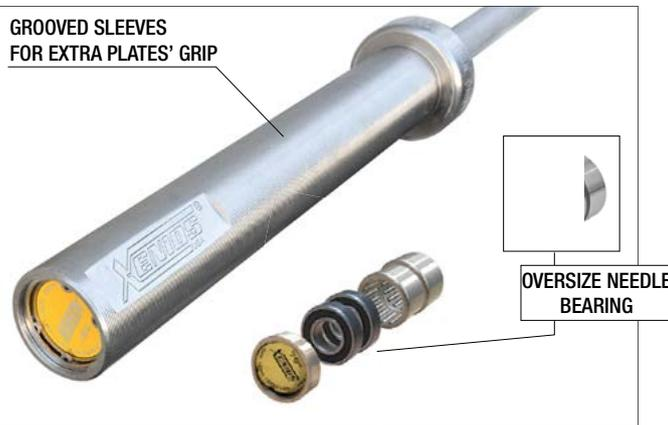

*1 COMPETITION AND PROFESSIONAL BARS Lifetime Warranty covers just bar's shaft breakages. Bar's shaft bents warranty is just 1 year time limited.

Bar's shaft breakages and/or bents warranty main terms: it is valid just when COMPETITION and/or PROFESSIONAL bars are used on a professional weightlifting platform (such as the Xenios USA® one) or equivalent kind of flooring, and loaded with the Xenios USA® rubber Bumper Plates or equivalent quality.

2 Year: on to all bar and sleeves construction parts.

1 Year: on to all bar and sleeves finishing. Rust due to proven missing maintenance and cleaning or misuse (e.g.: due to storage on to bare steel racks) is not covered under warranty.

All Warranties on COMPETITION and PROFESSIONAL bars are void in case of negligent or faulty use, alteration, maintenance, storage or handling by the user. Negligent or faulty use includes abusive dropping of the bar (i.e., dropping the bar on to a not proper floor (10 mm. thick rubber flooring and lower are considered not proper), a box, bench, spotter arms or pins in a power rack, excessive dropping with insufficient or damaged bumpers, or dropping with iron plates, and similar usage). For any further about Xenios USA® products' warranty, please refer to the Xenios USA® Warranty Chart, available at www.xeniosusa.com



BARS



TRAINING BARS

READY FOR OLYMPIC LIFTING



XSOBAR08 R2F TRAINING BAR - 86" Man Olympic Bar

WEIGHT (Kg./Lbs)	L (cm.)
20 / 44	220

- 86" Bronze Oxide finished (shaft) + Hard Chrome finished (sleeves) - 1665Mpa Heat Treated-Spring Steel - Man Olympic Bar w/oversize bronze bushings and dual snap ring closing system - 240.000 PSI - 1500 Lbs max. load 220 cm. - 28 mm. - 20 Kg. - Olympic IWF & IPF marks w/o center mark

- ⚠ Equipped with special heavy duty needle bearings. Double thickness; Longer Needles; Self-Lubricating channel.
- ⚠ All Xenios USA® bars are not pre-equipped with collars.



TRAINING BARS

READY FOR OLYMPIC LIFTING



XSOBAR07 TRAINING BAR - 86" Man Olympic Bar

WEIGHT (Kg./Lbs)	L (cm.)
20 / 44	220

- 86" Bright Zinc Plated + Black E-coating (shaft) & Bright Zinc Plated (sleeves) - 60Mn Heat Treated-Spring Steel Man Olympic Bar w/bronze bushings and dual snap ring closing system - 180.000+ PSI - 1000 Lbs max. load 220 cm. - 28 mm. - 20 Kg. - Olympic IWF & IPF marks w/o center mark

- ⚠ All Xenios USA® bars are not pre-equipped with collars.



BARS



TRAINING BARS

READY FOR OLYMPIC LIFTING



XSOBAR09 TRAINING LADY'S BAR - 79" Woman Olympic Bar

WEIGHT (Kg./Lbs)	L (cm.)
15 / 33	201

- 79" Bright Zinc Plated + E-coated surface (shaft) w/Bright Zinc Plated sleeves - 60Mn-Heat Treated Spring Steel Woman Olympic Bar w/bronze bushings and dual snap ring closing system - 180.000+ PSI - 500 Lbs max. load - 201 cm. - 25 mm. - 15 Kg. - Olympic IWF & IPF marks w/o center mark

⚠ All Xenios USA® bars are not pre-equipped with collars.

GROOVED SLEEVES FOR EXTRA PLATES' GRIP



COMING SOON



ALUMINUM TECHNIQUE BARS



PSAOBAR01 ALU TECHNIQUE BAR - 86" Olympic Bar

WEIGHT (Kg./Lbs)	L (cm.)
10 / 22	220

- 86" Aluminum Olympic Bar w/6 bearings (2xdouble-case needle + 4xball) and dual snap ring closing system - 220 cm. - 28 mm. - 10 Kg. - Olympic IWF & IPF marks w/o center mark

⚠ Equipped with special heavy duty needle bearings. Double thickness; Longer Needles; Self-Lubricating channel.

⚠ All Xenios USA® bars are not pre-equipped with collars.

⚠ 100 Lbs (50 Kg.) max.load.

GROOVED SLEEVES FOR EXTRA PLATES' GRIP



OVERSIZE NEEDLE BEARING

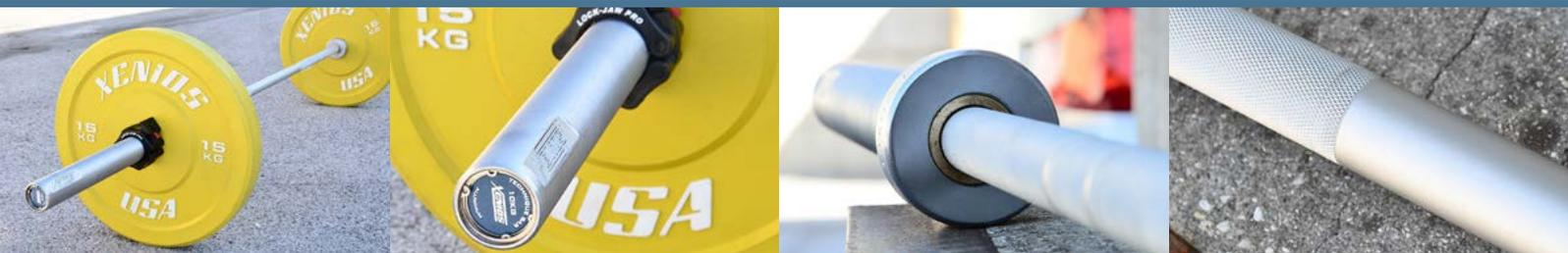

BARS

ALUMINUM TECHNIQUE BARS



PSAOBAR02 ALU JUNIOR TECHNIQUE BAR - 72" Junior Bar

WEIGHT (Kg./Lbs)	L (cm.)
5 / 11	180

- 72" Aluminum Junior Bar - 60 Lbs (30 Kg.) max.load - 180 cm. - 25 mm. - 5 Kg. - Olympic IWF marks w/o center mark

- △ All Xenios USA® bars are not pre-equipped with collars.
- △ 60 Lbs (30 Kg.) max.load.



CHROMED OVERSIZE BARS



PSO0BAR01 86" Chromed finish Oversize Olympic Bar

WEIGHT (Kg./Lbs)	L (cm.)
32 / 70	220

- 500 Kg./1100 Lbs max. load - Material: steel - Finishing: chrome

- △ All Xenios USA® bars are not pre-equipped with collars.



PSO0BAR02 47" Chromed finish Oversize Olympic Bar

WEIGHT (Kg./Lbs)	L (cm.)
15 / 33	120

- 200 Kg./450 Lbs max. load - Material: steel - Finishing: chrome

- △ All Xenios USA® bars are not pre-equipped with collars.



BARS

SPECIALITY BARS

XSLEARNBAR01 PE - Learning Bar - 59" x 28.5 mm.

WEIGHT (Kg./Lbs)	L (cm.)
0.3 / 0.66	150

- IN/OUT Markers for Weight and Olympic Lifting Technique Learning
- Material: PE - Color: black



SPECIALITY BARS

PSearthQK THE EARTHQUAKE BAR by Bandbell® - 77"

WEIGHT (Kg./Lbs)	L (cm.)
14 / 30	195

- 50 Kg./110 Lbs max. load - Grip diameter: 38 mm
- Material: bamboo

⚠ All Xenios USA® bars are not pre-equipped with collars.



COMING SOON

PSOHQBAR02 SHORT FLAT HEXAGONAL BAR - 59" x 24" x 24" Single Handle

WEIGHT (Kg./Lbs)	L (cm.)	W (cm.)
20 / 44	150	60

- 250 Kg./550 Lbs max. load - Grip diameter: 25 mm
- Material: steel - Finishing: NP plated

⚠ All Xenios USA® bars are not pre-equipped with collars.



PSOHQBAR01 HEXAGONAL BAR - 71" x 24" x 24" Double-Handle

WEIGHT (Kg./Lbs)	L (cm.)	W (cm.)
30 / 66	180	60

- 450 Kg./1000 Lbs max. load - Grip diameter: 25 mm
- Material: steel - Finishing: NP plated

⚠ All Xenios USA® bars are not pre-equipped with collars.



PSOHQBAR03 STRONGMAN HEXAGONAL BAR - 63" x 24" x 24" Double-Handle



WEIGHT (Kg./Lbs)	L (cm.)	W (cm.)
38 / 84	160	64

- 450 Kg./1000 Lbs max. load - Grip diameter: 32 mm
- Material: Steel - Finishing: NP plated

⚠ All Xenios USA® bars are not pre-equipped with collars.



BARS

SPECIALITY BARS

PSSQBAR01 CAMBERED SQUAT BAR - 89.7" x 51.5"



WEIGHT (Kg./Lbs)	L (cm.)	W (cm.)
22.5 / 49.5	228	45

- 350 Kg./771 Lbs max. load - 30 mm. grip dia. - 3 bar's pads included
- Can fit gym racks
- Material: steel - Finishing: NP plated

⚠ All Xenios USA® bars are not pre-equipped with collars.



PSSWBAR01 SWISS BAR - 84"



WEIGHT (Kg./Lbs)	L (cm.)	W (cm.)
22 / 48.5	215	19

- 450 Kg./1000 Lbs max. load - 30 mm. grip dia. - 4 grasping positions
- Can fit gym racks
- Material: steel - Finishing: NP plated

⚠ All Xenios USA® bars are not pre-equipped with collars.

⚠ Plates are not included.



SPECIALITY BARS

PSAXLBAR01 82.6" Black Coated Long Axle

WEIGHT (Kg./Lbs)	L (cm.)
12 / 26	210



- 300 Kg./660 Lbs max. load
- Can fit gym racks
- Material: Powder coated steel
- Color: matte black
- Grip diameter: 50 mm

⚠ All Xenios USA® bars are not pre-equipped with collars.

PSAXLBAR02 60" Black Coated Short Axle

WEIGHT (Kg./Lbs)	L (cm.)
9 / 20	152



- 150 Kg./330 Lbs max. load
- Material: Powder coated steel
- Color: matte black
- Grip diameter: 50 mm

⚠ All Xenios USA® bars are not pre-equipped with collars.



2" GRIP (50 mm)



BARS ACCESSORIES

COLLARS

VSOSCL01 2" Olympic Spring collar w/ 90° grip

- Center hole diameter 50 mm.
- Material: steel - Color: chrome



WEIGHT LIFTING COLLARS

READY FOR OLYMPIC LIFTING

XSOSSCL01 Chromed finish steel Olympic Spring Loaded Weight Lifting Collar - 2.5 kg.

- Center hole diameter 50 mm.
- Material: steel - Color: chrome



LOCK-JAW®

LJC-PRO 2" Pro Lock-Jaw® Olympic Barbell Collar

- Equipped with safety locking system



LJC-ELI 2" ELITE Lock-Jaw® Olympic Barbell Collar

- Inner steel grid to reinforce the whole collar
- Equipped with safety locking system



EXTRA
STRENGTHNESS
STEEL-WIRE
INNER CAGE FOR
INFINITY DROPS

LOCK-JAW® is a Patented Design and a Registered Trademark used by and under license from Avus Design LLC - CA(USA).

GYM CHAINS

VSPGGC01 59" Progressive Gym Chain w/ Olympic Collar - 6 kg.

VSPGGC02 59" Progressive Gym Chain w/ Olympic Collar - 8 kg.

VSPGGC03 59" Progressive Gym Chain w/ Olympic Collar - 12 kg.

VSPGGC04 91" Progressive Gym Chain w/ Olympic Collar - 9 kg.

VSPGGC05 91" Progressive Gym Chain w/ Olympic Collar - 12 kg.

VSPGGC06 91" Progressive Gym Chain w/ Olympic Collar - 15 kg.



BARS ACCESSORIES

POWER RESISTANCE LOOPS

CAN BE STRETCHED UP TO 8 TIMES THE REST-LENGTH

XSSQESLP01 BLACK Squat Power Resistance Loop - Extra Light

- 41" (104 cm. dia.) - 1/2" (1.25 cm.) width - 4.5 mm. thick
- 16 Kg./35 Lbs max resistance

XSSQESLP02 RED Squat Power Resistance Loop - Light

- 41" (104 cm. dia.) - 3/4" (2.05 cm.) width - 4.5 mm. thick
- 23 Kg./50 Lbs max resistance

XSSQESLP03 PURPLE Squat Power Resistance Loop - Medium

- 41" (104 cm. dia.) - 1.125" (2.85 cm.) width - 4.5 mm. thick
- 36 Kg./80 Lbs max resistance

XSSQESLP04 GREEN Squat Power Resistance Loop - Heavy

- 41" (104 cm. dia.) - 1.75" (4.5 cm.) width - 4.5 mm. thick
- 55 Kg./120 Lbs max resistance

XSSQESLP05 BLUE Squat Power Resistance Loop - Extra Heavy

- 41" (104 cm. dia.) - 2.5" (6.4 cm.) width - 4.5 mm. thick
- 75 Kg./165 Lbs max resistance

XSBPESLP01 BLACK Bench Press Power Resistance Loop - Extra Light

- 20" (51 cm. dia.) - 1/2" (1.25 cm.) width - 3 mm. thick
- 7.5 Kg./16.5 Lbs max resistance

XSBPESLP02 RED Bench Press Power Resistance Loop - Light

- 20" (51 cm. dia.) - 3/4" (2.05 cm.) width - 3 mm. thick
- 10 Kg./22 Lbs max resistance

XSBPESLP03 PURPLE Bench Press Power Resistance Loop - Medium

- 20" (51 cm. dia.) - 1.125" (2.85 cm.) width - 3 mm. thick
- 20 Kg./44 Lbs max resistance

XSBPESLP04 GREEN Bench Press Power Resistance Loop - Heavy

- 20" (51 cm. dia.) - 1.75" (4.5 cm.) width - 3 mm. thick
- 30 Kg./66 Lbs max resistance

XSBPESLP05 BLUE Bench Press Power Resistance Loop - Extra Heavy

- 20" (51 cm. dia.) - 2.5" (6.4 cm.) width - 3 mm. thick
- 35 Kg./77 Lbs max resistance



BARBELL TOOLS

XSBARCLEAN Cleaning and Maintenance Kit for Bars' care - Suitable for: Hard Chromed - NP Plated - Black Oxide

- Cleaning and Maintenance Kit for Bars' care - Cleaning Steel Brush + Cleaning Fiber Brush + Cleaning Cloth + Lube Oil for mechanic parts + Silicon Grease for galvanized steel surfaces + Seeger Jaw for sleeve maintenance

XSBARLUBE01 Special Spray Oil to lube Bars, Bearings and Bushings - 125 ml.

- To lube shafts and sleeves
- To keep bushing and bearings lubricated

XSBARLUBE02 Special Silicon Spray Grease to lube and to protect Galvanized Steel Bars and Sleeves - 200 ml.

- To lube shafts and sleeves
- To keep bushing and bearings lubricated



BARBELLS RACKS

RKSPBR02 Vertical Bars Rack - 5 sleeves

WEIGHT (Kg./Lbs)	L (cm.)	W (cm.)	H (cm.)
15 / 33	70	37	26

- N° bars support: 1 PC to 5 PCs - Material: powder coated steel - Color: matte black
- Max. load: 200 kg.
- Steel tubes thickness: 2.5 mm.

⚠ Bars are not included

ANTI-TILT WEIGHTED
BASE



RKSPBR03 Vertical Bars Rack - 10 sleeves

WEIGHT (Kg./Lbs)	L (cm.)	W (cm.)	H (cm.)
25 / 55	125	37	26

- N° bars support: 1 PC to 10 PCs - Material: powder coated steel - Color: matte black
- Max. load: 400 kg.
- Steel tubes thickness: 2.5 mm.

⚠ Bars are not included

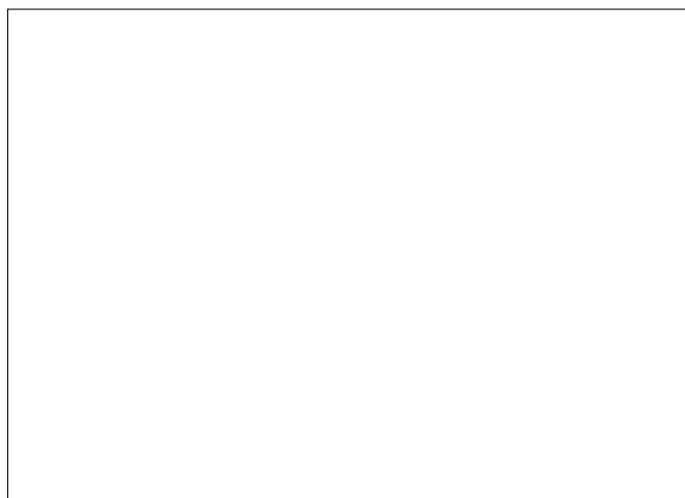

BARBELLS RACKS

RKSPBR05 Wall Mounted Bar Rack - Ready for Bars Care Option - 6 Bars

WEIGHT (Kg./Lbs)	L (cm.)	W (cm.)	H (cm.)
10 / 22	10.6	4.6	75

- N° bars support: 1 PC to 6 PCs - Material: powder coated steel - Color: matte black
- Width (per each support bar): 10 cm.
- Max. load: 120 kg.

⚠ Bars are not included



RKSPBR06 Bar's Care Option for Wall Mounted Bar Rack - 6 Bars

- Nylon support for bar long lasting

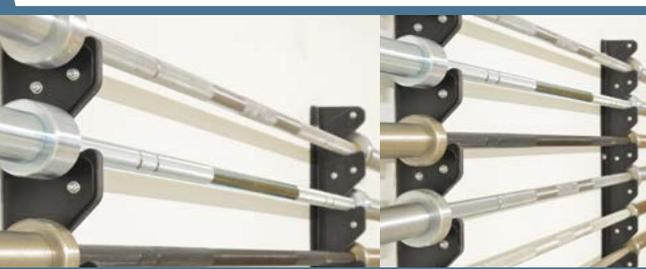

RKSPBR06





KETTLEBELLS

EVOLUTION CAST IRON KETTLEBELLS

- PSCIKBLH6 Evolution e-Coated Black Cast Iron Kettlebell - 6 Kg.
- PSCIKBLH8 Evolution e-Coated Black Cast Iron Kettlebell - 8 Kg.
- PSCIKBLH12 Evolution e-Coated Black Cast Iron Kettlebell - 12 Kg.
- PSCIKBLH16 Evolution e-Coated Black Cast Iron Kettlebell - 16 Kg.
- PSCIKBLH20 Evolution e-Coated Black Cast Iron Kettlebell - 20 Kg.
- PSCIKBLH24 Evolution e-Coated Black Cast Iron Kettlebell - 24 Kg.
- PSCIKBLH28 Evolution e-Coated Black Cast Iron Kettlebell - 28 Kg.
- PSCIKBLH32 Evolution e-Coated Black Cast Iron Kettlebell - 32 Kg.
- PSCIKBLH36 Evolution e-Coated Black Cast Iron Kettlebell - 36 Kg.
- PSCIKBLH40 Evolution e-Coated Black Cast Iron Kettlebell - 40 Kg.
- PSCIKBLH44 Evolution e-Coated Black Cast Iron Kettlebell - 44 Kg.
- PSCIKBLH48 Evolution e-Coated Black Cast Iron Kettlebell - 48 Kg.
- PSCIKBLH56 Strongman Evolution Black Powder Coated Cast Iron Kettlebell - 56 Kg.
- PSCIKBLH68 Strongman Evolution Black Powder Coated Cast Iron Kettlebell - 68 Kg.
- PSCIKBLH80 Strongman Evolution Black Powder Coated Cast Iron Kettlebell - 80 Kg.
- PSCIKBLH92 Strongman Evolution Black Powder Coated Cast Iron Kettlebell - 92 Kg.

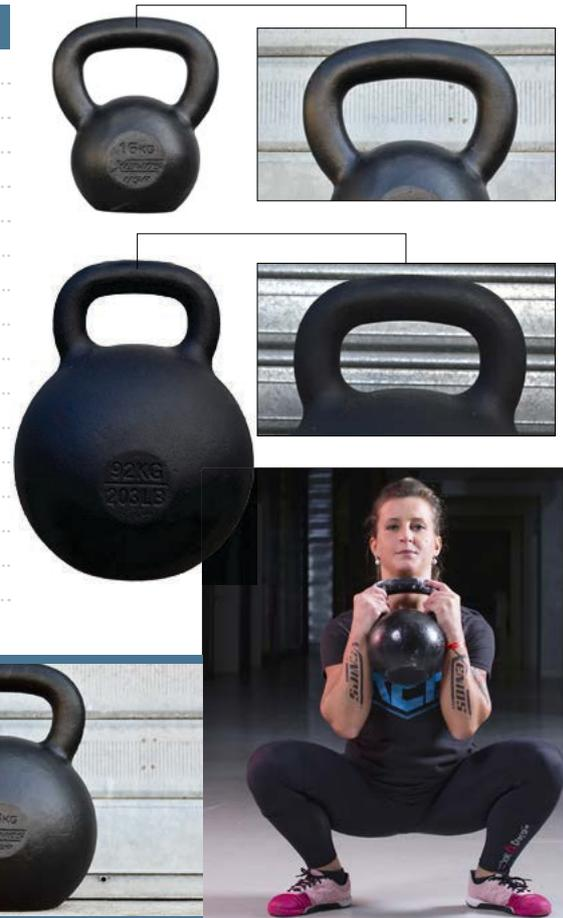

STEEL OLYMPIC KETTLEBELLS

- VSSTOKBL8 Light Blue Steel Olympic Kettlebell - 8 kg.
- VSSTOKBL12 Yellow Steel Olympic Kettlebell - 12 kg
- VSSTOKBL16 Dark Yellow Steel Olympic Kettlebell - 16 kg.
- VSSTOKBL18 Light Green Steel Olympic Kettlebell - 18 kg.
- VSSTOKBL20 Green Steel Olympic Kettlebell - 20 kg.
- VSSTOKBL24 Dark Green Steel Olympic Kettlebell - 24 kg.
- VSSTOKBL28 Red Steel Olympic Kettlebell - 28 kg.
- VSSTOKBL32 Dark Red Steel Olympic Kettlebell - 32 kg.
- VSSTOKBL36 Grey Steel Olympic Kettlebell - 36 kg.
- VSSTOKBL40 Bronze Steel Olympic Kettlebell - 40 kg.
- VSSTOKBL44 Gold Steel Olympic Kettlebell - 44 kg.



KETTLEBELLS

STEEL RUSSIAN GIREVOY COMPETITION KETTLEBELLS

- XSSTOKBL8** Pink Steel Russian Girevoy Competition Kettlebell - 8 Kg.

- XSSTOKBL12** Blue Steel Russian Girevoy Competition Kettlebell - 12 Kg.

- XSSTOKBL16** Yellow Steel Russian Girevoy Competition Kettlebell - 16 Kg.

- XSSTOKBL18** Purple/White Steel Russian Girevoy Competition Kettlebell - 18 Kg.

- XSSTOKBL20** Purple Steel Russian Girevoy Competition Kettlebell - 20 Kg.

- XSSTOKBL24** Green Steel Russian Girevoy Competition Kettlebell - 24 Kg.

- XSSTOKBL28** Orange Steel Russian Girevoy Competition Kettlebell - 28 Kg.

- XSSTOKBL32** Red Steel Russian Girevoy Competition Kettlebell - 32 Kg.

- XSSTOKBL36** Grey Steel Russian Girevoy Competition Kettlebell - 36 Kg.

- XSSTOKBL40** White Steel Russian Girevoy Competition Kettlebell - 40 Kg.

- XSSTOKBL44** Silver Steel Russian Girevoy Competition Kettlebell - 44 Kg.



NEOPRENE KETTLEBELLS

- XSNPKBL4** Light Green Neoprene Kettlebell - 4 Kg.

- XSNPKBL6** Light Blue Neoprene Kettlebell - 6 Kg.

- XSNPKBL8** Yellow Neoprene Kettlebell - 8 Kg.

- XSNPKBL10** Orange Kettlebell - 10 Kg.

- XSNPKBL12** Red Neoprene Kettlebell - 12 Kg.

- XSNPKBL16** Dark Green Neoprene Kettlebell - 16 Kg.

- XSNPKBL20** Dark Blue Neoprene Kettlebell - 20 Kg.



KETTLEBELLS

KETTLEBELL RACK

RKMSVSTKB04 Massive Storage Rack - Multistorage Unit for: Kettlebells

- Massive Storage Rack - Side Upright w/wheels - x2PCs
- Massive Storage Rack - Kettlebells Tier - x3PCs

WEIGHT (Kg./Lbs)	L (cm.)	W (cm.)	H (cm.)
75 / 165	201	50	123

- Material: Powder coated steel - steel tube thickness = 3,5 mm
- Color: Matte black

△ * Fractional Plates and Loop Bands Storages are sold as an option

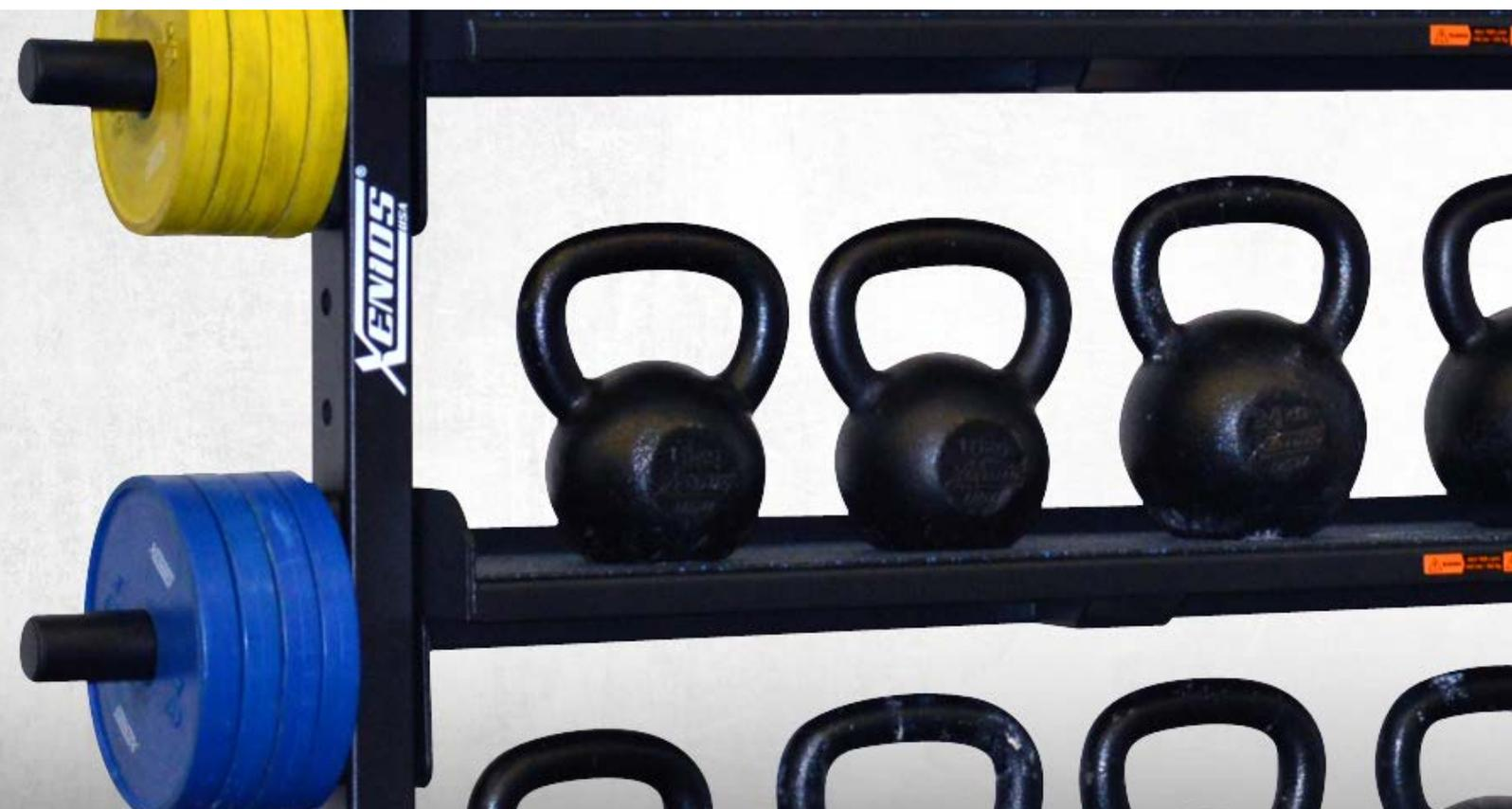
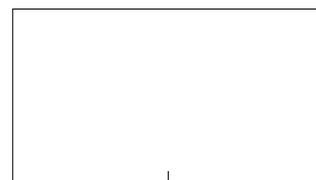

XENIOS[®]

USA



COACH ALBERTO GALLAZZI - European CST/TACFIT Headcoach & Military Division Chief



TACFIT® CLUBBELLS®

VSSTCB2.5 Tacfit® Clubbell® - 2.5 kg.

VSSTCB5 Tacfit® Clubbell® - 5 kg.

VSSTCB7 Tacfit® Clubbell® - 7 kg.

VSSTCB10 Tacfit® Clubbell® - 10 kg.

VSSTCB12 Tacfit® Clubbell® - 12 kg.

VSSTCB15 Tacfit® Clubbell® - 15 kg.

VSSTCB20 Tacfit® Clubbell® - 20 kg.

VSCICB2.5 Tacfit® Training Clubbell® - 2.5 kg.

VSCICB5 Tacfit® Training Clubbell® - 5 kg.

VSCICB7 Tacfit® Training Clubbell® - 7 kg.

VSCICB10 Tacfit® Training Clubbell® - 10 kg.

⚠ May be not available within all Countries



RKCB01 Tacfit Clubbells Rack - 14 slugs

WEIGHT (Kg./Lbs)	L (cm.)	W (cm.)	H (cm.)
20 / 44	102	40	12

- N° clubbells support: 2 PCs x sizes - Max. load: 72 kg./159 Lbs
 - Steel tubes thickness: 3 mm. - Material: powder coated steel - Color: matte black
 - 2x2,5 / 2x5 / 2x7 / 2x10 / 2x12 / 2x15 / 2x20

⚠ Clubbells are not included

⚠ The rack comes with the Training Set Adaptor so to store: (2pcs x 2.5Kg.)
 - (4pcs x 5Kg.) - (6pcs x 7Kg.) - (2pcs x 10Kg.)



RKCB02 Training Set Adaptor for Clubbells Rack (2x2.5 Kg. + 4x5 Kg. + 6x7 Kg. + 2x10 Kg.)

MATERIAL	FINISHING	WEIGHT (Kg./Lbs)	L (cm.)	W (cm.)	H (cm.)
NYLON	BLACK	1,4 / 3	102	40	0.6

⚠ Clubbells Rack is not included



* Tacfit® is a Registered Trademark used by and under license from RMAX.tv Productions and Secutor S.r.l. - (IT).

* Clubbell® is a Registered Trademark used by and under license from RMAX.tv Productions and Sconik International LLC - GA(USA).



TRAINING BAGS

TANK SAND-BAGS

XSSDBG01 Small Tank Sand-Bag 26" x 10" (66 cm. x 25,5 cm.) - w/2 Small Filler Bags 25.5" x 9.5" (65 cm. x 24 cm.) max.load 20 Lbs (10 Kg.) each - max.load 60 Lbs (30 Kg.)



MILITARY GRADE CORDURA®

XSSDBG02 Big Tank Sand-Bag 32" x 12" (82 cm. x 31 cm.) w/2 Big Filler Bags 32" x 12" (81 cm. x 30 cm.) - max.load 40 Lbs (20 Kg.) each - max.load 160 Lbs (80 Kg.)

XSFLBG01 Tank Sand-Bag - Small Filler bag 25.5" x 9.5" (65 cm. x 24 cm.) - max.load 20 Lbs (10 Kg.)

⚠ Tank Sand-Bags are sold empty



XSFLBG02 Tank Sand-Bag - Large Filler bag 32" x 12" (81 cm. x 30 cm.) - max.load 40 Lbs (20 Kg.)

⚠ Tank Sand-Bags are sold empty

SB-5KG Weighted bags dried-sand bag - 5 Kg.



SLAM SAND-BAGS

XSSDBG04 Medium Slam Sand-Bag - 19.7" x 7.8" (50 cm. x 20 cm.) w/ six handles - w/2 Filler Bags slam-proof 23.6" x 7.9" (60 cm. x 20 cm.) - 40 Lbs (20 Kg.) Max. load. each

⚠ Slam Sand-Bags are sold empty
⚠ May be not available within all Countries



SLAM PROOF BAGS



XSSDBG05 Big Slam Sand-Bag - 28" x 9.5" (72 cm. x 24 cm.) w/ six handles - w/2 Filler Bags slam-proof 32.2" x 8.7" (82 cm. x 22 cm.) - 70 Lbs (35 Kg.) Max. load. each

⚠ Slam Sand-Bags are sold empty
⚠ May be not available within all Countries



SB-5KG Weighted bags dried-sand bag - 5 Kg.



INNER FILLER BAGS WITH DOUBLE-VELCRO-SLAM-PROOF CLOSING SYSTEM



TRAINING BAGS

WATER BAGS

XSTWTBG01 Water Bag - Training 25 kg. max. (5" foot air pump included)

- Max Weight load: 20 kg./44 Lbs
- Total length: 75 cm.
- Diameter: 18 cm.



TRAINING BALLS

NO-BOUNCING SLAM BALLS

PSBCSBL5-1	5" No Bouncing Slam Ball - 1 kg. (13 cm.)
PSBCSBL5-2	5" No Bouncing Slam Ball - 2 kg. (13 cm.)
PSBCSBL5-3	5" No Bouncing Slam Ball - 3 kg. (13 cm.)
PSBCSBL9-4	9" No Bouncing Slam Ball - 4 kg. (23 cm.)
PSBCSBL9-5	9" No Bouncing Slam Ball - 5 kg. (23 cm.)
PSBCSBL9-6	9" No Bouncing Slam Ball - 6 kg. (23 cm.)
PSBCSBL9-8	9" No Bouncing Slam Ball - 8 kg. (23 cm.)
PSBCSBL9-10	9" No Bouncing Slam Ball - 10 kg. (23 cm.)
PSBCSBL9-12	9" No Bouncing Slam Ball - 12 kg. (23 cm.)
PSBCSBL10-15	10" No Bouncing Slam Ball - 15 kg. (25 cm.)
PSBCSBL10-20	10" No Bouncing Slam Ball - 20 kg. (25 cm.)
PSBCSBL10-25	10" No Bouncing Slam Ball - 25 kg. (25 cm.)
PSBCSBL12-30	12" No Bouncing Slam Ball - 30 kg. (30 cm.)

STRONGMAN MED BALLS

PSBCSBL14-30	14" Strongman Med Ball - 30 Kg. (65 Lbs - 35 cm.)
PSBCSBL14-40	14" Strongman Med Ball - 40 Kg. (90 Lbs - 35 cm.)
PSBCSBL14-50	14" Strongman Med Ball - 50 Kg. (110 Lbs - 35 cm.)
PSBCSBL14-60	14" Strongman Med Ball - 60 Kg. (130 Kbs - 35 cm.)
PSBCSBL14-70	14" Strongman Med Ball - 70 Kg. (150 Lbs - 35 cm.)
PSBCSBL14-80	14" Strongman Med Ball - 80 Kg. (180 Kbs - 35 cm.)
PSBCSBL14-90	14" Strongman Med Ball - 90 Kg. (200 Lbs - 35 cm.)
PSBCSBL14-100	14" Strongman Med Ball - 100 Kg. (220 Lbs - 35 cm.)



TRAINING BALLS

NO-BOUNCING WALL BALLS

XSBCWBL4 14" No Bouncing Wall Ball - 4 kg. (35 cm.)

XSBCWBL6 14" No Bouncing Wall Ball - 6 kg. (35 cm.)

XSBCWBL9 14" No Bouncing Wall Ball - 9 kg. (35 cm.)

XSBCWBL12 14" No Bouncing Wall Ball - 12 kg. (35 cm.)

DOUBLE CORD SEALING



TRAINING BALLS

NO-BOUNCING WALL BALLS

XSWBPSG01 Wall Ball Power Sling

⚠ No-Bouncing Wall Ball is not included



RKRWB05 Wall Ball 3-tiers Storage Rack w/wheels (12 pcs)

WEIGHT (Kg./Lbs)	L (cm.)	W (cm.)	H (cm.)
26 / 57	160	63	130

- N° Wall Ball support: 1 PC to 12 PCs
- Max. load: 180 kg./397 Lbs
- Steel tubes thickness: 1.5 mm.
- Material: Powder coated steel - Finishing: Matte black

⚠ No-Bouncing Wall Ball is not included



TRAINING BALLS

NO-BOUNCING WALL BALLS

RKMSVSTWB05 Massive Storage Rack - Multistorage Unit for: Wallballs

- Massive Storage Rack - Side Upright w/wheels - x2PCs
- Massive Storage Rack - WallBalls Tier - x2PCs
- Massive Storage Rack - Bumpers and WallBalls Tier - x1PC

WEIGHT (Kg./Lbs)	L (cm.)	W (cm.)	H (cm.)
50 / 110	201	50	123

- Material: Powder coated steel - steel tube thickness = 3,5 mm
- Color: Matte black

⚠ * Fractional Plates and Loop Bands Storages are sold as an option



TRAINING BALLS

BOUNCING MED BALLS

XSSMBL3	Standard Med Ball - 3 kg.
XSSMBL4	Standard Med Ball - 4 kg.
XSSMBL5	Standard Med Ball - 5 kg.
XSSMBL6	Standard Med Ball - 6 kg.
XSSMBL7	Standard Med Ball - 7 kg.
XSSMBL8	Standard Med Ball - 8 kg.
XSSMBL9	Standard Med Ball - 9 kg.
XSSMBL10	Standard Med Ball - 10 kg.



DOUBLE GRIP MED BALLS

XSDGMBL3	Double Grip Med Ball - 3 kg.
XSDGMBL4	Double Grip Med Ball - 4 kg.
XSDGMBL5	Double Grip Med Ball - 5 kg.
XSDGMBL6	Double Grip Med Ball - 6 kg.
XSDGMBL7	Double Grip Med Ball - 7 kg.
XSDGMBL8	Double Grip Med Ball - 8 kg.
XSDGMBL9	Double Grip Med Ball - 9 kg.
XSDGMBL10	Double Grip Med Ball - 10 kg.



ROPE MED BALLS

PSRPMBL1	Rope Med Ball - 1 kg.
PSRPMBL2	Rope Med Ball - 2 kg.
PSRPMBL3	Rope Med Ball - 3 kg.
PSRPMBL4	Rope Med Ball - 4 kg.
PSRPMBL5	Rope Med Ball - 5 kg.
PSRPMBL6	Rope Med Ball - 6 kg.
PSRPMBL7	Rope Med Ball - 7 kg.

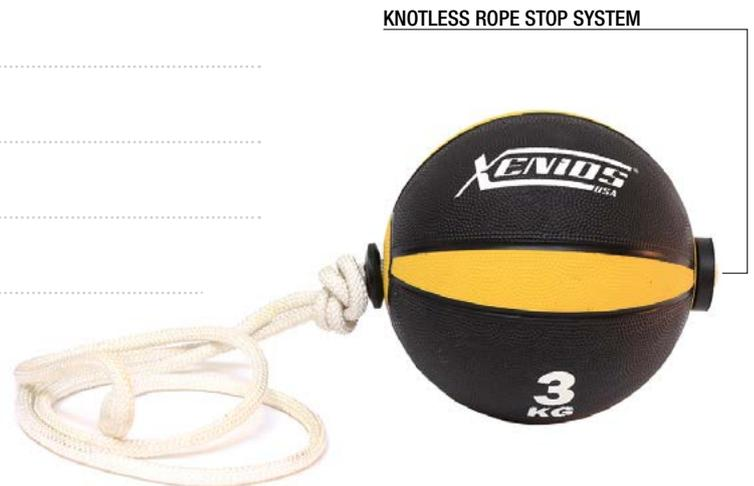

TRAINING BALLS

MED BALLS TOOLS

XSMBRB01 Med Balls Rebounder

WEIGHT (Kg./Lbs)	Net dia. (cm.)	H (cm.)
15 / 33	100	60

- Material: Powder coated steel - Color: Grey/Black

ADJUSTABLE GRADE



UP TO 12 KG MED-BALLS



MED BALLS RACKS

RKMDBL01 Vertical single side Med Balls Rack - 5 balls

WEIGHT (Kg./Lbs)	L (cm.)	W (cm.)	H (cm.)
10 / 22	65	35	162

- N° Ball support: 1 PC to 5 PCs
 - Max. load: 50 kg./110 Lbs
 - Steel tubes thickness: 1.5 mm.
 - Material: Powder coated steel - Color: Silver



RKMDBL03 Medicine Balls Rack w/ wheels - 3 tiers

WEIGHT (Kg./Lbs)	L (cm.)	W (cm.)	H (cm.)
23 / 51	150	63	103

- N° Ball support: 1 PC to 21 PCs (1 kg.)
 - Max. load: 180 kg./397 Lbs
 - Steel tubes thickness: 1.5 mm.
 - Material: Powder coated steel - Color: Silver





TRAINING ROPES

TRAINING ROPES

VSPURP01 1.5" x 24" Natural Fiber Pull Up Rope (rope eyelet included) - (38 mm. x 60 cm.)

VSPURP02 2" x 24" Natural Fiber Pull Up Rope (rope eyelet included) - (50 mm. x 60 cm.)



VSSTRP01 1.5" x 35" Natural Fiber Short Rope - (38 mm. x 90 cm.)

VSSTRP03 1.5" x 70" Natural Fiber Short Rope - (38 mm. x 180 cm.)

VSSTRP02 2" x 35" Natural Fiber Short Rope - (50 mm. x 90 cm.)

VSSTRP04 2" x 70" Natural Fiber Short Rope - (50 mm. x 180 cm.)



VSCBRP01 1.5" x 20' Natural Fiber Climbing Rope - 38 mm. x 6 m.

- Steel eyelet included - pre-mounted on to the rope



VSCBRP02 1.5" x 20' Natural Fiber Climbing Rope - 38 mm. x 6 m.

- Pre-knotted rope eyelet end
- Suitable for learning purposes



VSCBRP03 1.5" x 20' Natural Fiber Climbing Rope w/16" apart knots (40 cm. apart)
- 38 mm. x 6 m.

- Pre-knotted rope eyelet end

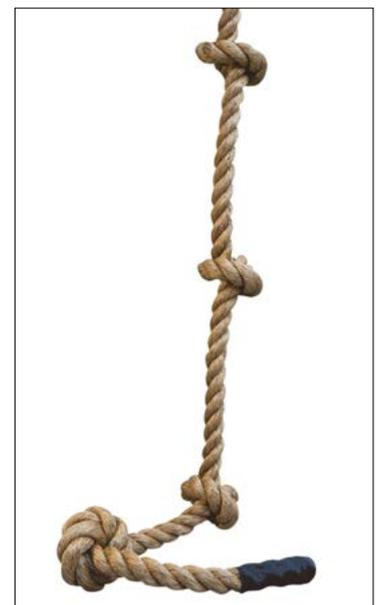

COMING SOON



TRAINING ROPES

TRAINING ROPES

VSPWRP01 1.5" x 50' Nylon Training Rope

- Wall mounted ring included
- 38 mm. x 15 m. - 0.86 Kg./m.



VSPWRP02 2" x 50' Nylon Training Rope (50 mm. x 15 m.) - 1.46 Kg./m.

- Wall mounted ring included
- 50 mm. x 15 m. - 1.46 Kg./m.



VSPWRP03 1.5" x 50' Nylon encased, Natural Sisal Training Rope

- (38 mm. x 15 m.) - 0,85 Kg./m.
- Wall mounted ring included



VSPWRP04 2" x 50' Nylon encased, Natural Sisal Training Rope

- (50 mm. x 15 m.) - 1.35 Kg./m.
- Wall mounted ring included



VSPWRP06 1.8" x 50' Nylon encased, Natural Hemp Heavy Duty Training Rope

- (44 mm. x 15 m.) - 2.00 Kg./m.

LEADS OVERLOADED



VSRPEY01 1.5" Rope Eyelet

VSRPEY02 2" Rope Eyelet



TRAINING ROPES

TRAINING ROPES

VSRPEY03 Wall Mounted Bracket for Climbing Rope

ALSO SUITABLE AS STATION FOR:

- GYM RINGS
- BOXING BAG
- CLIMBING ROPE

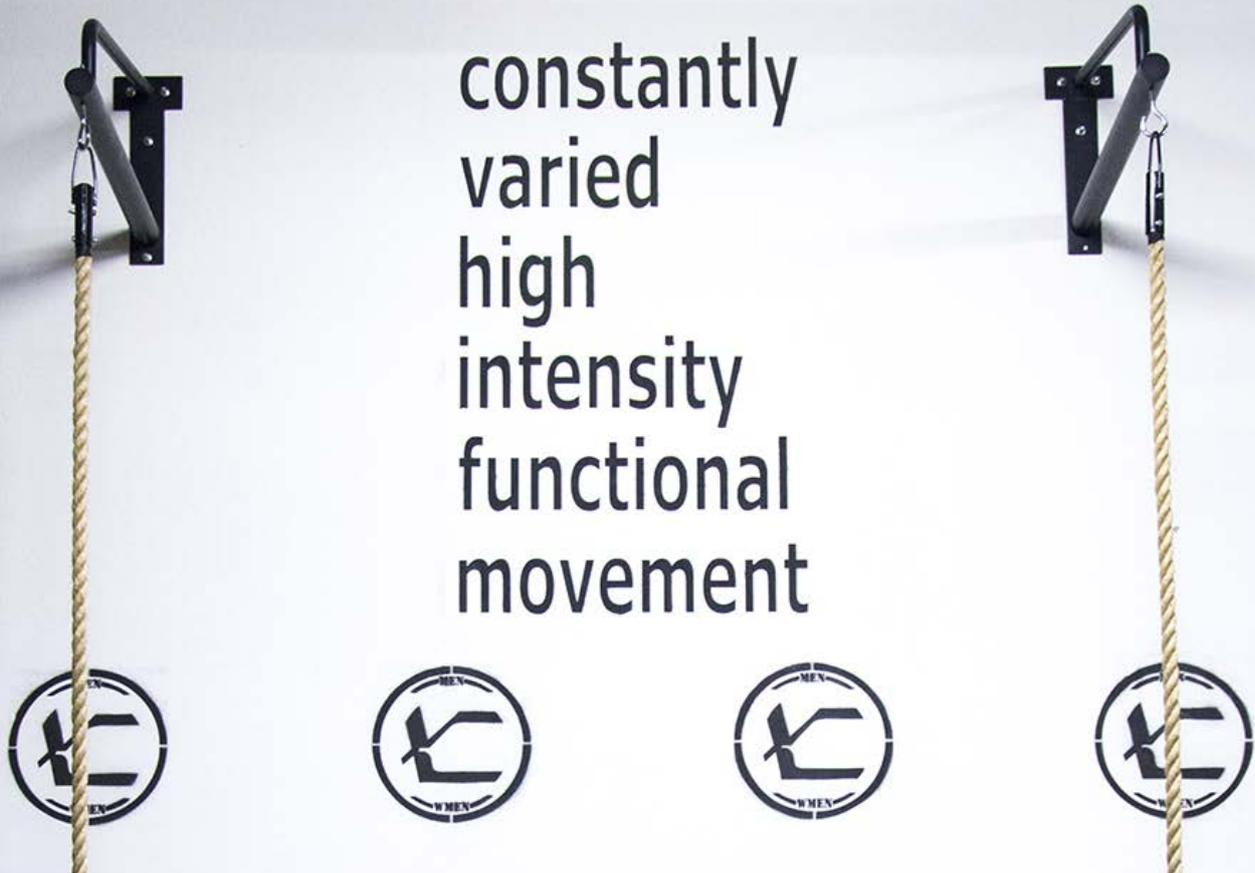

constantly
varied
high
intensity
functional
movement

VSAXFIT32 XRIG™ - Junction Bar Anchoring Tool for Rings and Rope w/carabiners and Swivels

WEIGHT (Kg./Lbs)	L (cm.)	W (cm.)	H (cm.)
5.2 / 11.5	10	16	15

- Material: Powder coated steel - Color: Matte black

⚠ VSXFIT09 and VSCBRP01 are not included.

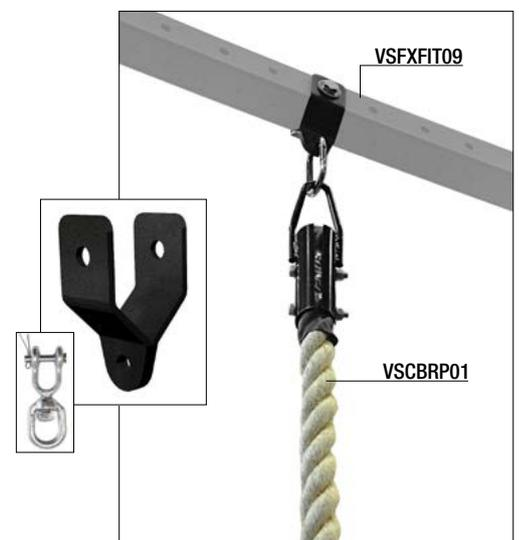



KENTOS[®]
USA

TRAINING SLEDS

TRAINING SLEDS

XSGSD01 Just Drag Sled

WEIGHT (Kg./Lbs)	L (cm.)	W (cm.)	H (cm.)
10 / 22	61	40	46

- Max. load: 150 kg./331 Lbs
- Material: Powder coated steel - Color: Matte black
- Ready to be equipped with Nylon/UHMW/Polyzene skies (nylon pulling straps and carabiners included)

⚠ Plates are not included

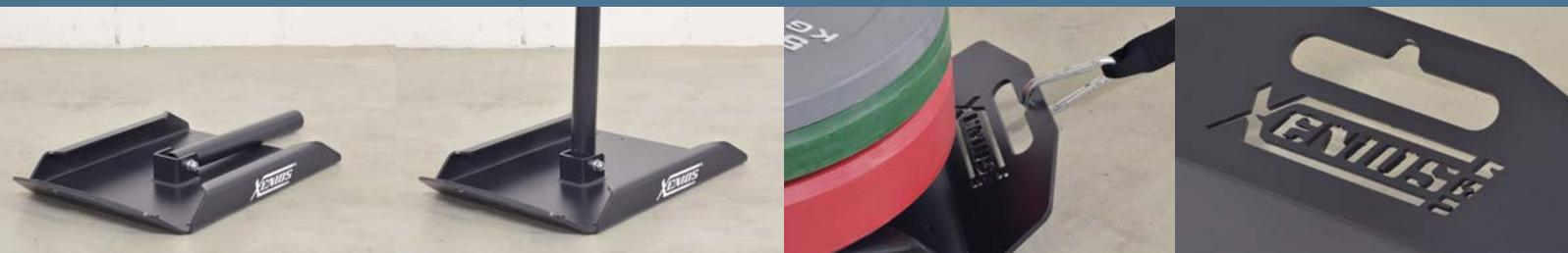

XSGSD01NS All Surfaces Nylon Skies for Just Drag Sled

XSGSD01US Concrete and Asphalt PE-UHMW Skies for Just Drag Sled

XSGSD01PS Rubber Flooring Polyzene Skies for Just Drag Sled



TRAINING SLEDS

TRAINING SLEDS

XSPGSD01 The Prowler Sled

WEIGHT (Kg./Lbs)	L (cm.)	W (cm.)	H (cm.)
50 / 110	109	100	100

- Max. load: 700 kg./1.543 Lbs
- Material: Powder coated steel - Color: Matte black
- Nylon pulling straps and carabiners included

⚠ Plates are not included



XSPGSD02 The Prowler Sled w/Nylon Skies - M.Y. 2015

WEIGHT (Kg./Lbs)	L (cm.)	W (cm.)	H (cm.)
50 / 110	109	100	100

- Max. load: 700 kg./1.543 Lbs
- Material: Powder coated steel - Color: Matte black
- Nylon pulling straps and carabiners included



XSPGSD01NS All Surface Nylon Skies for The Prowler Sled - M.Y. 2015

XSPGSD01US Concrete and Asphalt PE-UHMW Skies for The Prowler Sled - M.Y. 2015

XSPGSD01PS Rubber Flooring Polyzene Skies for The Prowler Sled - M.Y. 2015

XSPGSD01SS Replacement Steel Ski for The Prowler Sled - M.Y. 2015

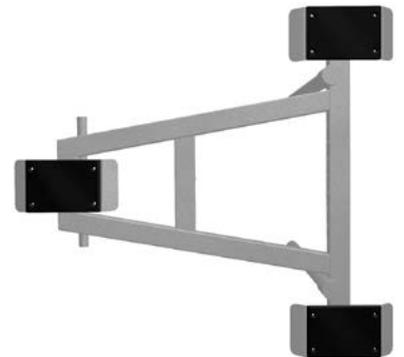

TRAINING SLEDS

TRAINING SLEDS

XSGSD03 Round-Trip Sled w/nylon skies

WEIGHT (Kg./Lbs)	L (cm.)	W (cm.)	H (cm.)
47 / 104	102	61	97

- Max. load: 350 kg./772 Lbs
- Material: Powder coated steel - Color: Matte black
- (XSGSD04) Nylon skies for Round-trip Sled included (to work on all floor kinds)

⚠ Plates are not included



M16 BOLTS

NYLON SKIES INCLUDED



TRAINING SLEDS

TRAINING SLEDS

XSGD03WBK Wheel-Barrow Upgrade Kit for Round-Trip Sled

- Material: Powder coated steel - Color: Matte black



XSGD03WB Round Trip Sled w/Wheel-Barrow Kit (dual function)

WEIGHT (Kg./Lbs)	L (cm.)	W (cm.)	H (cm.)
67 / 148	172	61	97

- Max. load: 350 kg./772 Lbs
 - Material: Powder coated steel - Color: Matte black

⚠ Plates are not included



HANDLESS BARS CAN BE REMOVED TO USE IT AS A SLED



TRAINING SLEDS

TRAINING SLEDS

XSGD03PBH High Pushing Bar for Round-Trip Sled



XSGD03PBL Low Pushing Bar for Round-Trip Sled

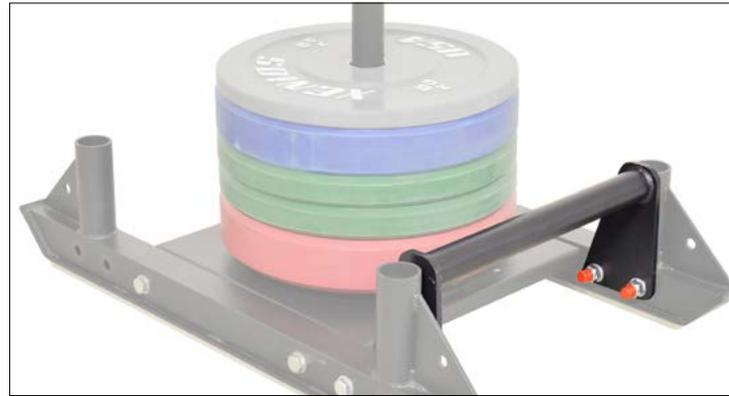

XSGD03PAR Pull-Around attachment for Round Trip Sled

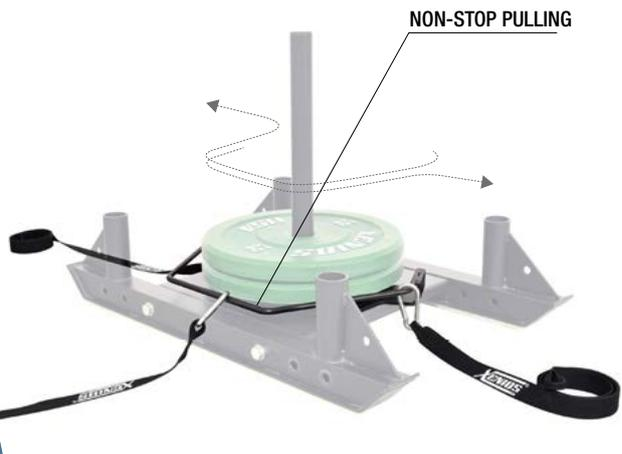

TRAINING SLEDS

TRAINING SLEDS

XSGSD03NS All Surface Nylon Skies for Round-Trip Sled

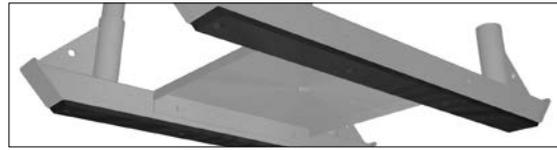

XSGSD03US Concrete and Asphalt PE-UHMW Skies for Round-Trip Sled

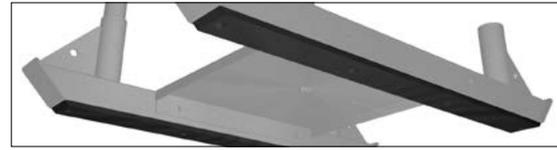

XSGSD03PS Rubber Flooring Polyzene Skies for Round-Trip Sled



XSDGSP01 Drag Strap

⚠ Sled is not included

STRAP WITH HANDLES
TO PULL THE SLED BY
BACKWARD RUNNING



TRAINING SLEDS

TRAINING SLEDS

XSSDHN01 Shoulder Harness w/rings

PERFECT FOR
HEAVY-LOADS PULLING



PSNYPLAT003 Full Power Belt

PERFECT FOR
HEAVY-LOADS PULLING



PSNYPLAT004 Technique 360° Ring Belt - Small (Dia.: 38 cm.)

PSNYPLAT005 Technique 360° Ring Belt - Medium (Dia.: 50 cm.)

PSNYPLAT006 Technique 360° Ring Belt - Large (Dia.: 62 cm.)



PLYOMETRIC BOXES

XSPMBX04 Contest Plyometric Box - one size fits three heights

- 20"-24"-30" (51cm. - 61cm. - 76cm.)
 - Material: Wood - Color: Wood

SAFE ROUNDED EDGES



INNER DOUBLE CROSS-MEMBER
 PRE-VARNISHED 1.8 cm. PINE PLYWOOD



XSPMBX04A TACFIT LIMITED Edition Contest Plyometric Box - one size fits three heights

- 20"-24"-30" (51cm. - 61cm. - 76cm.)
 - Material: Wood - Color: Wood



* Tacfit® is a Registered Trademark used by and under license from RMAX.tv Productions and Secutor S.r.l. - (IT).



PLYOMETRIC BOXES

XSPMBX06A Safe Training Soft Plyometric Box
- Stackable - 70x70 cm. x 6" height (15 cm.)

- 70-70-15 cm.
- Material: Foam+Sky - Color: Black
- Weight: 8 Kg

XSPMBX06B Safe Training Soft Plyometric Box
- Stackable - 70x70 cm. x 12" height (31 cm.)

- 70-70-31 cm.
- Material: Foam+Sky - Color: Black
- Weight: 16 Kg

XSPMBX06C Safe Training Soft Plyometric Box
- Stackable - 70x70 cm. x 20" height (51 cm.)

- 70-70-51 cm.
- Material: Foam+Sky - Color: Black
- Weight: 20 Kg

XSPMBX06D Safe Training Soft Plyometric Box
- Stackable - 70x70 cm. x 24" height (61 cm.)

- 70-70-61 cm.
- Material: Foam+Sky - Color: Black
- Weight: 24 Kg



PLYOMETRIC GEAR

PLYOMETRIC BOXES

XSPMBX03 Steel Plyometric Boxes - Training set - 3 boxes

- 30-45-60 cm.
- Material: Steel - Color: Black

ANTI-SLIP
EPDM PAD



XSPMBX05 Steel Plyometric Boxes - Sky Jump set - 2 boxes

- 65-90 cm.
- Material: Steel - Color: Black

ANTI-SLIP
EPDM PAD



PLYOMETRIC TOOLS

XSPWJP01 Power Jump Kit - Small

- 51" Green Nylon Encased Multi-use Elastic Tube - Light - x2PCs
- 51" Red Nylon Encased Multi-use Elastic Tube - Medium - x2PCs
- 51" Blue Nylon Encased Multi-use Elastic Tube - Heavy - x2PCs
- Technique Waist Belt w/rings - Small - x1PC
- 24" Strap anchor w/ring - (60 cm.) - x2PCs

XSPWJP02 Power Jump Kit - Large

- 51" Green Nylon Encased Multi-use Elastic Tube - Light - x2PCs
- 51" Red Nylon Encased Multi-use Elastic Tube - Medium - x2PCs
- 51" Blue Nylon Encased Multi-use Elastic Tube - Heavy - x2PCs
- Technique Waist Belt w/rings - Large - x1PC
- 24" Strap anchor w/ring - (60 cm.) - x2PCs



ACCELERATION AND AGILITY GEAR

ACCELERATION TOOLS

XSSDHN01 Shoulder Harness w/ rings

PERFECT FOR
HEAVY-LOADS PULLING



PSNYPLAT001 Technique Waist Belt w/rings - Small

PSNYPLAT002 Technique Waist Belt w/rings - Large



KIRSTIE ALLOY BUCKLE

PSNYPLAT003 Full Power Belt

PERFECT FOR
HEAVY-LOADS PULLING

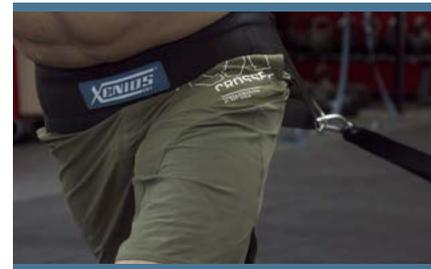

PSNYPLAT004 Technique 360° Ring Belt - Small (Dia.: 38 cm.)

PSNYPLAT005 Technique 360° Ring Belt - Medium (Dia.: 50 cm.)

PSNYPLAT006 Technique 360° Ring Belt - Large (Dia.: 62 cm.)



ACCELERATION AND AGILITY GEAR

ACCELERATION TOOLS

PSNYPLAT008 Technique Ankle/Wrist Cuff



PSNYPLAT007 Sprinter Ankle cuff w/rings



PSNYPLAT009 Technique Leg Cuff w/ring



PSNYPLAT010 Technique Arm Cuff w/ring



ACCELERATION AND AGILITY GEAR

ACCELERATION TOOLS

XSSTAC01 24" Strap Anchor w/ ring - (60 cm.)



XSANCB01 Anchoring Steel Ring w/steel heavy duty carabiner



XSTPBR01 Anchor Bar w/ rubber grips



XSWTBR01 43" Workout Bar w/360° rings and foam grip (107 cm.)

- The bar can be split in two parts for easy carrying

TO PERFORM BARBELL
SUSPENSION WORKOUTS



UP TO 8 USERS

XSWAS01 Wall Anchoring Station (wall and ceiling mount)



ACCELERATION AND AGILITY GEAR

POWER TUBES

XSSTESTB07 9' Nylon encased Multi-use Power Elastic Tube

- Color: Light Blue - Max resistance 75 Lbs. (34 Kg.)

XSSTESTB08 9' Nylon encased Multi-use Extra Power Elastic Tube

- Color: Orange - Max resistance 105 Lbs. (48 Kg.)

XSSTESTB09 9' Nylon encased Multi-use Over Power Elastic Tube

- Color: Purple - Max resistance 150 Lbs. (68 Kg.)

XSSTESTB01 51" Green Nylon Encased Multi-use Elastic Tube

- Color: Light Blue - Resistance: Light (Max resistance 12 Lbs. / 5.5 Kg.)

XSSTESTB02 51" Red Nylon Encased Multi-use Elastic Tube

- Color: Orange - Resistance: Medium (Max resistance 14 Lbs. / 6.6 Kg.)

XSSTESTB03 51" Blue Nylon Encased Multi-use Elastic Tube

- Color: Purple - Resistance: Heavy (Max resistance 19 Lbs. / 9 Kg.)

XSSTESTB04 71" Green Nylon Encased Multi-use Elastic Tube

- Color: Light Blue - Resistance: Light (Max resistance 12 Lbs. / 5.5 Kg.)

XSSTESTB05 71" Red Nylon Encased Multi-use Elastic Tube

- Color: Orange - Resistance: Medium (Max resistance 14 Lbs. / 6.6 Kg.)

XSSTESTB06 71" Blue Nylon Encased Multi-use Elastic Tube

- Color: Purple - Resistance: Heavy (Max resistance 19 Lbs. / 9 Kg.)

XSSDSP01 Spider Sprinter Kit

- 71" Green Nylon Encased Multi-use Elastic Tube - Light - x2PCs**
- 71" Red Nylon Encased Multi-use Elastic Tube - Medium - x2PCs**
- 71" Blue Nylon Encased Multi-use Elastic Tube - Heavy - x2PCs**
- Sprinter Ankle Cuff w/rings - x2PCs**
- Technique Leg Cuff w/ring - x2PCs**
- Technique Arm Cuff w/ring - x2PCs**
- Anchor Bar w/rubber grips - x1PC**
- 24" Strap anchor w/ring - (60 cm.) - x1PC**
- Anchoring Steel Ring w/steel heavy duty carabiner - x1PC**



ACCELERATION AND AGILITY GEAR

AGILITY TOOLS

XSSAGLD01 Adjustable/Modular 13' Agility Ladder

- 4 m. x 50 cm. - 18" (47.5 cm.) width sections



PSHRD01 Portable and Height-Adjustable Hurdle

- 100x10 cm. (Sold in 10 PCs boxes)

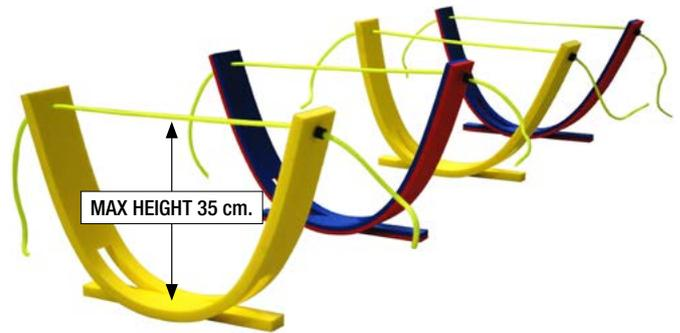

ASCONE01 Space marker cone - Yellow/Orange

- Weight 2 Kg. - Height 5 Cm. - Package 24 Pcs (12+12 Pcs)

ASCONE02 Space marker cone - White/Blue

- Weight: 2 Kg. - Height: 5 Cm. - Package: 24 Pcs (12+12 Pcs)



A40CONE01 Agility Cone - Fluo Yellow - 40 cm. (H.)

- Weight: 6 Kg. - Height: 40 Cm. - Package: 30 Pcs

A40CONE02 Agility Cone - Fluo Orange - 40 cm. (H.)

- Weight: 6 Kg. - Height: 40 Cm. - Package: 30 Pcs



A30CONE01 Agility Cone w/hurdle bar holes - 30 cm. (H.) - Blue

- Weight: 5 Kg. - Height: 30 Cm. - Package: 24 Pcs

A30CONE02 Agility Cone w/hurdle bar holes - 30 cm. (H.) - Green

- Weight: 5 Kg. - Height: 30 Cm. - Package: 24 Pcs

A30CONE03 Agility Cone w/hurdle bar holes - 30 cm. (H.) - Fluo Yellow

- Weight: 5 Kg. - Height: 30 Cm. - Package: 24 Pcs

A30CONE04 Agility Cone w/hurdle bar holes - 30 cm. (H.) - Fluo Orange

- Weight: 5 Kg. - Height: 30 Cm. - Package: 24 Pcs



ACCELERATION AND AGILITY GEAR

AGILITY TOOLS

A30CONEBAR01 Safe Hurdle Bar for 30 cm. Agility Cones - Fluo Yellow

- Weight 3.5 Kg. - Length: 160 Cm. - Diameter: 25 mm. - Package 36 Pcs

A30CONEBAR02 Safe Hurdle Bar for 30 cm. Agility Cones - Fluo Orange

- Weight 3.5 Kg. - Length: 160 Cm. - Diameter: 25 mm. - Package 36 Pcs

SFHRD10 Safe Hurdle - 10 cm. (H.) x 100 cm. (L.) - Yellow

- Weight 2,5 Kg. - Length: 100 Cm. - Height 10 Cm. - Package 12 Pcs

SFHRD20 Safe Hurdle - 20 cm. (H.) x 100 cm. (L.) - Yellow

- Weight 3 Kg. - Length: 100 Cm. - Height 20 Cm. - Package 12 Pcs

SFHRD30 Safe Hurdle - 30 cm. (H.) x 100 cm. (L.) - Yellow

- Weight 4 Kg. - Length: 100 Cm. - Height 30 Cm. - Package 12 Pcs

SFHRD40 Safe Hurdle - 40 cm. (H.) x 100 cm. (L.) - Yellow

- Weight 5 Kg. - Length: 100 Cm. - Height 40 Cm. - Package 12 Pcs

SFHRD50 Safe Hurdle - 50 cm. (H.) x 100 cm. (L.) - Yellow

- Weight 6 Kg. - Length: 100 Cm. - Height 50 Cm. - Package 12 Pcs

SFHRD60 Safe Hurdle - 60 cm. (H.) x 100 cm. (L.) - Yellow

- Weight 7.5 Kg. - Length: 100 Cm. - Height 60 Cm. - Package 12 Pcs

HDHRD10 Hard Hurdle - 10 cm. (H.) x 120 cm. (L.) - Yellow

- Weight 2.5 Kg. - Length: 120 Cm. - Height 10 Cm. - Package 12 Pcs

HDHRD20 Hard Hurdle - 20 cm. (H.) x 120 cm. (L.) - Yellow

- Weight 3 Kg. - Length: 120 Cm. - Height 20 Cm. - Package 12 Pcs

HDHRD30 Hard Hurdle - 30 cm. (H.) x 120 cm. (L.) - Yellow

- Weight 4 Kg. - Length: 120 Cm. - Height 30 Cm. - Package 12 Pcs

HDHRD40 Hard Hurdle - 40 cm. (H.) x 120 cm. (L.) - Yellow

- Weight 5 Kg. - Length: 120 Cm. - Height 40 Cm. - Package 12 Pcs

HDHRD50 Hard Hurdle - 50 cm. (H.) x 120 cm. (L.) - Yellow

- Weight 6 Kg. - Length: 120 Cm. - Height 50 Cm. - Package 12 Pcs

HDHRD60 Hard Hurdle - 60 cm. (H.) x 120 cm. (L.) - Yellow

- Weight 7.5 Kg. - Length: 120 Cm. - Height 60 Cm. - Package 12 Pcs

HDRTHRD40 Return Hard Hurdle w/heavy back stand - 40 cm. (H.) x 120 cm. (L.) - Yellow

- Weight 5 Kg. - Length: 120 Cm. - Height 40 Cm. - Package 9 Pcs

HDRTHRD50 Return Hard Hurdle w/heavy back stand - 50 cm. (H.) x 120 cm. (L.) - Yellow

- Weight 6 Kg. - Length: 120 Cm. - Height 50 Cm. - Package 9 Pcs

HDRTHRD60 Return Hard Hurdle w/heavy back stand - 60 cm. (H.) x 120 cm. (L.) - Yellow

- Weight 7,5 Kg. - Length: 120 Cm. - Height 60 Cm. - Package 9 Pcs



JUMP ROPES

JUMP ROPES

PS3DJRP01 Pro-Bearing Double Under-er Jump Rope

- Aluminum Handles
- Double Bearing System
- It comes with two ropes: bare steel (1.6 mm) and nylon coated (2.2 mm)



1. STEEL SNAP RING
2. ZZ SELF-LUBE BEARINGS
3. SWIVEL SPHERE HOUSING
4. SELF-LUBRICATE SWIVEL BRASS SPHERE
5. HEADLESS SCREW M3X3
6. SAFETY END CAP



PS3DBJRPNB High Speed Bushing Double Under-er Jump Rope w/Aluminum Handles - Navy Blue



PS3DBJRPBK High Speed Bushing Double Under-er Jump Rope w/Aluminum Handles - Black



PS3DBJRPPK High Speed Bushing Double Under-er Jump Rope w/Aluminum Handles - Pink



PS3DBJRPPR High Speed Bushing Double Under-er Jump Rope w/Aluminum Handles - Purple



PS3DBJRPGR High Speed Bushing Double Under-er Jump Rope w/Aluminum Handles - Green



PS3DBJRPHYW High Speed Bushing Double Under-er Jump Rope w/Aluminum Handles - Yellow



- Aluminum Handles
- Double Bearing System
- It comes with two ropes: bare steel (1.6 mm) and nylon coated (2.2 mm)

XSPJRP01BL Ultra-Speed Jump Rope w/plastic handles - Navy Blue

XSPJRP01BK Ultra-Speed Jump Rope w/plastic handles - Black

XSPJRP01PK Ultra-Speed Jump Rope w/plastic handles - Pink

XSPJRP01PP Ultra-Speed Jump Rope w/plastic handles - Purple

XSPJRP01GR Ultra-Speed Jump Rope w/plastic handles - Light Green

XSPJRP01YL Ultra-Speed Jump Rope w/plastic handles - Yellow

NYLON COATED ROPE THICKNESS: 2.2 mm



GYMNASTIC AND BODYWEIGHT GEAR

GYMNASTIC RINGS

XSWDRG01 1.25" Gymnastic Wood Ring (32mm.) grip - 300 Kg. Tested

- 300 Kg. Tested

CNC MADE FROM
A SOLID WOOD LOG



1.25" GRIP



1.11" GRIP

XSWDRG02 1.11" Gymnastic Wood Ring (28mm.) Gymnastic FIG Spec grip - 300 Kg. Tested

- 300 Kg. Tested



XSPWRG01 1.25" Power Steel Ring - (32 mm.) grip - Grippy Powder Coating - 500 Kg. Tested

- Grippy Powder Coating
- 500 Kg. Tested



GYMNASTIC AND BODYWEIGHT GEAR

GYMNASTIC RINGS

XSSTBK01 16.4' Heavy duty Strap Anchor w/cam-buckle - (500 cm.)



XSSTBK03 16.4' TACFIT® Limited Edition - Heavy duty Strap Anchor w/cam-buckle

- 500 cm.
- Color: Desert sand



XSSTBK02 6' Competiton Strap for Gymnastic Rings w/carabiners - (185 cm.)



XSSW01 Gymnastic Ring Steel Swivel for 360° attachment



* Tacfit® is a Registered Trademark used by and under license from RMAX.tv Productions and Secutor S.r.l. - (IT).



GYMNASTIC AND BODYWEIGHT GEAR

GYMNASTIC RINGS

THE PERFECT TOOL
TO TEACH MUSCLE-UPS

XSTHRTK Technique Kit for Gymnastic Rings

- Adjustable Belt w/multi-slug back straps
- Nylon Rope w/ steel hooks
- Steel Pulley
- Anywhere anchor Strap
- 23.5" Strap w/cam-buckle (60 cm.)

- ⚠ Rings are not included
- ⚠ Download the 'How-to-use' video from www.xeniosusa.com

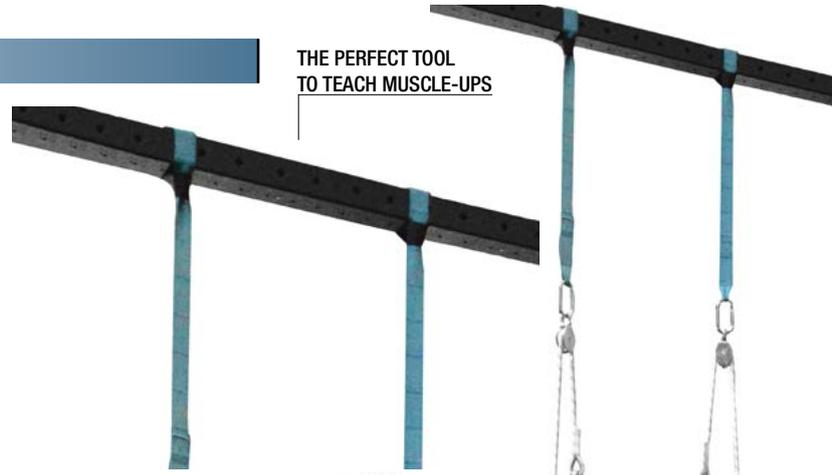

BODYWEIGHT STRAPS

XSPUSP01 Pull-Up Strap



XSLGRSP01 Leg Raise Strap



XSDPST01 Dipping Strap w/chain



XSDPBL01 Dipping Belt w/chain

- ⚠ Plate is not included



TESTED UP TO 500 kg.





MASTER SCOTT SONNON - Founder CST/Tacfit

GYMNASTIC AND BODYWEIGHT GEAR

BODYWEIGHT GYM

PSBDWTGY02 Bodyweight GYM (Suspension training kit) - BASIC

- Nylon carry bag
- Adjustable straps w/cam-buckles and carabiners
- Anywhere Anchor Staps
- Universal strap handles w/double cradle
- Y-Kit (for unbalanced workouts)
- Neoprene carabiner's covers



PSBDWTGY01 Bodyweight GYM (Suspension training kit) - PRO

- Bodyweight GYM back-pack
- Adjustable straps w/cam-buckles and carabiners
- Anywhere Anchor Straps
- Door Anchors
- Universal strap handles w/double cradle
- Steel Power rings w/anchor straps
- Head Strap
- Neoprene carabiner's covers
- Y-Kit (for unbalanced workouts)



GYMNASTIC AND BODYWEIGHT GEAR

BODYWEIGHT GYM

XSWTBR01 43" Workout Bar w/360° rings and foam grip (107 cm.)

- The bar can be split in two parts for easy carrying

TO PERFORM BARBELL
SUSPENSION WORKOUTS



UP TO 8 USERS

XSWAS01 Wall Anchoring Station (wall and ceiling mount)

BODYWEIGHT BARS AND HANDLES

XSSTPUBAR01 Suspended Pull-Up Bar w/Straps

WEIGHT (Kg./Lbs)	L (cm.)	W (cm.)	H (cm.)
3 / 7	120	-	-

- Frame Material: Powder coated steel - Color: Matte Black
- Bar Thickness: 32 mm. Strap Length: 300 cm.



GYMNASTIC AND BODYWEIGHT GEAR

BODYWEIGHT BARS AND HANDLES

VSPUBAR01 Wall-Mounted Pull-Up Bar

WEIGHT (Kg./Lbs)	L (cm.)	W (cm.)	H (cm.)
10 / 22	130	76	100

- Frame Material: Powder coated steel - Color: Matte Black
- Steel tube thickness: 2,5 mm. - Max load: 150 kg. - Max Tested load: 450 Kg.
- Pull-up Bar dia: 32 mm
- It comes with two Pull-up bars and it can be mounted either double or single
- Wall or ceiling mounted
- It can be series-mounted

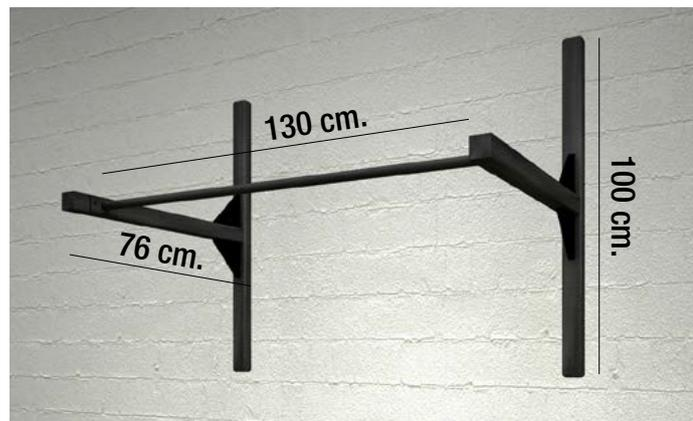

VSEQLZ02 Parallettes

WEIGHT (Kg./Lbs)	L (cm.)	W (cm.)	H (cm.)
8 / 18	40	60	30

- Frame Material: Powder coated steel - Color: Matte Black
- Steel tube thickness: 2 mm. - Max load: 150 kg.
- Inter locking crossmember

⚠ Abdominal Mat is not included

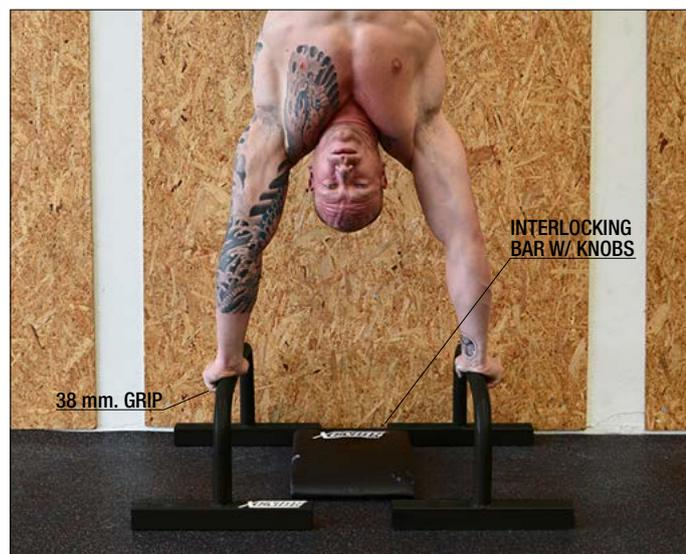

VSEQLZ03 Parallettes - TACFIT® Limited Edition

WEIGHT (Kg./Lbs)	L (cm.)	W (cm.)	H (cm.)
8 / 18	40	60	30

- Frame Material: Powder coated steel - Color: Army green
- Steel tube thickness: 2 mm. - Max load: 150 kg.
- Inter locking crossmember

⚠ Abdominal Mat is not included

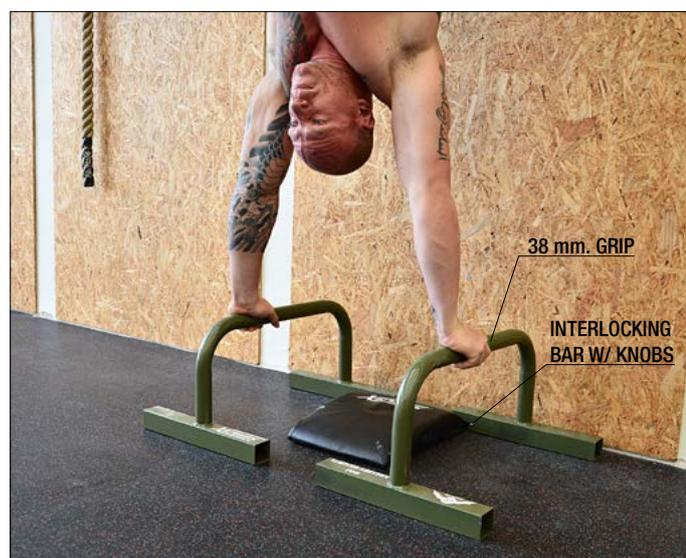

* Tacfit® is a Registered Trademark used by and under license from RMAX.tv Productions and Secutor S.r.l. - (IT).



BODYWEIGHT BARS AND HANDLES

XSCP01 Callisthenic Parallel Bars

WEIGHT (Kg./Lbs)	L (cm.)	W (cm.)	H (cm.)
50 / 110	230	60	160

- Material: Powder coated steel - Color: Black
- Steel tube thickness: 3,5 mm.



PSSLW01 Beech Wood Swedish Ladder - Wall mounted - Single Unit 250 cm. x 90 cm. (H x L)

WEIGHT (Kg./Lbs)	L (cm.)	W (cm.)	H (cm.)
20 / 44	90	30	250

- Material: Beech wood - Color: Color wood
- Bars Size: 40x30 mm.



PSSLW02 Beech Wood Swedish Ladder - Wall mounted - Double Unit 250 cm. x 180 cm. (H x L)

WEIGHT (Kg./Lbs)	L (cm.)	W (cm.)	H (cm.)
35 / 77	180	30	250

- Material: Beech wood - Color: Color wood
- Bars Size: 40x30 mm.



PSHOUTW02 Heavy Duty Steel Push-Up Twister Handle

- Material: Powder coated steel - Color: Matte Black
- Inner bushing revolving system
- Wide base for max stability



GYMNASTIC AND BODYWEIGHT GEAR

BODYWEIGHT BENCHES AND STATIONS

VSGHD02 Strongman GHD Bench

WEIGHT (Kg./Lbs)	L (cm.)	W (cm.)	H (cm.)
60 / 132	175	102	130

- Material: Powder coated steel - Color: Matte Black
- Steel tube thickness: 3,5 mm.
- Max user bodyweight: 180 kg. - Max tested load: 450 Kg.



ADJUSTABLE FEET ROLLERS DISTANCE

POWER RESISTANCE
LOOP ANCHORING PIN

DOUBLE KNOB
LOCKING SYSTEM

3 mm. THICK STEEL TUBES



BODYWEIGHT BENCHES AND STATIONS

RKBWWT01 Bodyweight Workout Rack - 5' (1.5 m.) (up to 2 users)

WEIGHT (Kg./Lbs)	L (cm.)	W (cm.)	H (cm.)
80 / 176	257	256	250

- Frame Material: Powder coated steel - Color: Matte Black/Grey
 - Steel tube thickness: 3 mm. - Max user bodyweight: 300 kg.



RKBWWT02 Bodyweight Workout Rack - 6' 7" (2 m.) (up to 4 users)

WEIGHT (Kg./Lbs)	L (cm.)	W (cm.)	H (cm.)
100 / 220.5	307	256	250

- Frame Material: Powder coated steel - Color: Matte Black/Grey
 - Steel tube thickness: 3 mm. - Max user bodyweight: 600 kg.



RKBWWT03 Bodyweight Workout Rack - 10' (3 m.) (up to 6 users)

WEIGHT (Kg./Lbs)	L (cm.)	W (cm.)	H (cm.)
120 / 264.5	407	256	250

- Frame Material: Powder coated steel - Color: Matte Black/Grey
 - Steel tube thickness: 3 mm. - Max user bodyweight: 900 kg.



GYMNASTIC AND BODYWEIGHT GEAR

BODYWEIGHT MATS

XSABDMT01 Abdominal Mat

WEIGHT (Kg./Lbs)	L (cm.)	W (cm.)	H (cm.)
0.3 / 0.6	38	30	8

- Material: PU coated firm foam - Color: Black



FIRM FOAM:
READY TO BEAR HEAVY BODYWEIGHT



XSEMT01 NBR Exercise Mat w/rings - long - 71" x 23.6" x 5/8" (180 x 60 x 1.5 cm.)



XSEMT02 NBR Exercise Mat w/rings - short - 55" x 23.6" x 5/8" (140 x 60 x 1.5 cm.)



RKMAT05 Training Mats Wall-Mounting Rack

WEIGHT (Kg./Lbs)	L (cm.)	W (cm.)	H (cm.)
6 / 13	65	7	21.5

- Material: Powder coated steel - Color: Matte black
- Min. / Max. loadable mats: 1 to 30 (4 mm. thickness)
- Max. load: 50 kg. - Steel plate thickness: 5 mm.

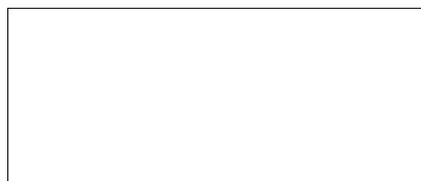

GYMNASTIC AND BODYWEIGHT GEAR

POWER RESISTANCE LOOPS

CAN BE STRETCHED UP TO 8 TIMES THE REST-LENGTH

XSSQESLP01 BLACK Squat Power Resistance Loop - Extra Light

- 41" (104 cm. dia.) - 1/2" (1.25 cm.) width - 4.5 mm. thick
- 16 Kg./35 Lbs max resistance

XSSQESLP02 RED Squat Power Resistance Loop - Light

- 41" (104 cm. dia.) - 3/4" (2.05 cm.) width - 4.5 mm. thick
- 23 Kg./50 Lbs max resistance

XSSQESLP03 PURPLE Squat Power Resistance Loop - Medium

- 41" (104 cm. dia.) - 1.125" (2.85 cm.) width - 4.5 mm. thick
- 36 Kg./80 Lbs max resistance

XSSQESLP04 GREEN Squat Power Resistance Loop - Heavy

- 41" (104 cm. dia.) - 1.75" (4.5 cm.) width - 4.5 mm. thick
- 55 Kg./120 Lbs max resistance

XSSQESLP05 BLUE Squat Power Resistance Loop - Extra Heavy

- 41" (104 cm. dia.) - 2.5" (6.4 cm.) width - 4.5 mm. thick
- 75 Kg./165 Lbs max resistance



GYMNASTIC AND BODYWEIGHT GEAR

CAN BE STRETCHED UP TO 8 TIMES THE REST-LENGTH

POWER RESISTANCE LOOPS

XSBPESLP01 BLACK Bench Press Power Resistance Loop - Extra Light

- 20" (51 cm. dia.) - 1/2" (1.25 cm.) width - 3 mm. thick
- 7.5 Kg./16.5 Lbs max resistance

XSBPESLP02 RED Bench Press Power Resistance Loop - Light

- 20" (51 cm. dia.) - 3/4" (2.05 cm.) width - 3 mm. thick
- 10 Kg./22 Lbs max resistance

XSBPESLP03 PURPLE Bench Press Power Resistance Loop - Medium

- 20" (51 cm. dia.) - 1.125" (2.85 cm.) width - 3 mm. thick
- 20 Kg./44 Lbs max resistance

XSBPESLP04 GREEN Bench Press Power Resistance Loop - Heavy

- 20" (51 cm. dia.) - 1.75" (4.5 cm.) width - 3 mm. thick
- 30 Kg./66 Lbs max resistance

XSBPESLP05 BLUE Bench Press Power Resistance Loop - Extra Heavy

- 20" (51 cm. dia.) - 2.5" (6.4 cm.) width - 3 mm. thick
- 35 Kg./77 Lbs max resistance

XSSPESLP01 BLACK Shorty Power Resistance Loop - Extra Light

- 12" (31 cm. dia.) - 1/2" width (1.25 cm.) - 4,5 mm. thick
- 14 Kg./30 Lbs max resistance

XSSPESLP02 RED Shorty Power Resistance Loop - Light

- 12" (31 cm. dia.) - 3/4" width (2.05 cm.) - 4,5 mm. thick
- 23 Kg./50 Lbs max resistance

XSSPESLP03 PURPLE Shorty Power Resistance Loop - Medium

- 12" (31 cm. dia.) - 1.13" width (2.85 cm.) - 4,5 mm. thick
- 30 Kg./65 Lbs max resistance



31 cm. DIA.



UNCONVENTIONAL GEAR

WEIGHTED VESTS

VSWGVT01 Neoprene Runner's weighted Vest - 5 kg.

⚠ Straps and Rings are not included



VSWGVT04 Nylon Shaped weighted Vest - 10 kg. max

- 10 cast iron bricks 1 kg. each included



VSWGVT03 Nylon Heavy weighted Vest - 30 kg. max

- 30 cast iron bricks 1 kg. each included

⚠ Straps and Rings are not included



VSWGVT01 Nylon Adjustable Short weighted Vest - 36 lbs. (16 kg.) max

- 12 cast iron bricks 3 lbs. / 1.5 kg. each included



UNCONVENTIONAL GEAR

VIKING HAMMER

VSVKHM4 Black Training Viking Hammer - 4 kg.

VSVKHM6 Black Training Viking Hammer - 6 kg.

VSVKHM8 Black Training Viking Hammer - 8 kg.

VSVKHM10 Black Training Viking Hammer - 10 kg.

VSVKHM12 Black Training Viking Hammer - 12 kg.

VSVKHM15 Black Training Viking Hammer - 15 kg.

VSVKHM20 Black Training Viking Hammer - 20 kg.

VSVKHM25 Black Training Viking Hammer - 25 kg.

VSVKHM30 Black Training Viking Hammer - 30 kg.

VSVKHM35 Black Training Viking Hammer - 35 kg.

VSVKHM40 Black Training Viking Hammer - 40 kg.



XSRBTBK01 Rubber Tank Block - 24" x 12" x 10" (60 x 30 x 25 cm.)
- 115 Lbs (52 kg.) - Color: black

XSRBTBK02 Rubber Tank Block - 24" x 12" x 10" (60 x 30 x 25 cm.)
- 115 Lbs (52 kg.) - Color: navy blue

XSRBTBK03 Rubber Tank Block - 24" x 12" x 10" (60 x 30 x 25 cm.)
- 115 Lbs (52 kg.) - Color: black - w/interlocking ends

XSRBTBK04 Rubber Tank Block - 24" x 12" x 10" (60 x 30 x 25 cm.)
- 115 Lbs (52 kg.) - Color: navy blue - w/interlocking ends

XSRBTBK05 Rubber Tank Block - Interlocking Pin set

INTERLOCKING PIN OPTION
AVAILABLE ON DEMAND



UNCONVENTIONAL GEAR

GRIP TRAINING

VSWRRL01 Pro Wrist Roller (can fit 2" plates)



FGRIPZ01 Fatgripz®



- Grip Diameter: 5 cm.
- Material: PU-Rubber

FatGripz® is a Patented Design and a Registered Trademark used by and under license from Fat Gripz Enterprises.



PGRIPS 2" Powergrip

- Grip Diameter: 5 cm.
- Material: PU-Rubber



**SPECIAL GRIP
KNURLED SURFACE**



VSGPSG01 Strongmen Spring - 100 Lbs (50 kg.)

VSGPSG02 Strongmen Spring - 200 Lbs (100 kg.)

VSGPSG03 Strongmen Spring - 300 Lbs (150 kg.)



UNCONVENTIONAL GEAR

GRIP TRAINING

VSAXFIT52 XRIG™ - 12" Strongmen Pull-Up Globe w/carabiner and strap (30 cm.)

WEIGHT (Kg./Lbs)	Dia. (cm.)
5.8 / 12.7	30

- Material: Powder coated steel - Color: Matte black - Carabiner and Strap included

VSAXFIT55 XRIG™ - 3" Strongmen Pull-Up Marble w/carabiner and strap (8 cm.)

WEIGHT (Kg./Lbs)	Dia. (cm.)
1.8 / 4	8

- Material: Powder coated steel - Color: Matte black - Carabiner and Strap included

VSAXFIT53 XRIG™ - 5" Strongmen Pull-Up Marble (13 cm.)

WEIGHT (Kg./Lbs)	Dia. (cm.)
1.2 / 2.6	13

- Material: Powder coated steel - Color: Matte black - Carabiner and Strap included

VSAXFIT54 XRIG™ - 3" Strongmen Pull-Up Marble (8 cm.)

WEIGHT (Kg./Lbs)	Dia. (cm.)
1.2 / 2.6	8

- Material: Powder coated steel - Color: Matte black - Carabiner and Strap included



3"



5"

3"



UNCONVENTIONAL GEAR

CORE TRAINING

VSTCT02 Core Trainer

- Material: Chromed Steel



VSTCVB01 Core Trainers V-Bar

VSTCSD01 Core Trainers Single grip handle



WATER PIPES

XSWTPP01 86" Water Pipe (220 cm.)



XSWTPP02 106" Water Pipe (270 cm.)



STATIONS FOR WEIGHT AND POWER LIFTING

RKXFIT17 XRIG™ RACK 4'x 6' x 9' - w/ Power Lifting Cage

- XRIG™ - 9' Basic Upright (270 cm.) x6PCs
- XRIG™ - 4' Basic Pull-Up frame (108 cm.) x2PCs
- XRIG™ - Power Bands Pegs Cross Member (to be used with Power Lifting Cage) x4PCs
- XRIG™ - Back Cross Member (to be used with Power Lifting Cage) x2PCs
- XRIG™ - Plates Sleeve x6PCs
- XRIG™ - Safety Strap Anchoring Tool (to be used with Power Lifting Cage) x2PCs
- XRIG™ - 2"x55" Nylon Safety Strap w/HD Carabiner (Max.Load 1200 Kg.) (to be used with Power Lifting Cage) x2PCs
- XRIG™ - Safety Spotter Arm x2PCs
- XRIG™ - Bar J-Rack x4PCs

WEIGHT (Kg./Lbs)	L (cm.)	W (cm.)	H (cm.)
233 / 513	120	180	270

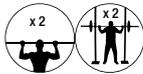

- Material: Powder coated steel - Color: Matte black
- Steel tubes size: 60x60x3.5 mm. + 32x4 mm. round tubes.

⚠ Should you got an XFIT Rack already, it can be upgraded to the Powerlifting Cage by using the "Powerlifting Cage-rack upgrade kit (VSXFIT17)".

- *2 - Pull-Up heights: 6'10"-7'6"-8'3" (only w/12' Uprights)
- Can be switched with: Double Cross Member (VSXFIT22/23)/Muscle-Up (VSXFIT28/21/36/37) /Offset Pull-Up Frame (VSXFIT01/06)/Offset Pull-Up Bar (VSXFIT35/36)
- Pull-Up heights: 8'74"-6'10"

XRIG™ configurations come disassembled.

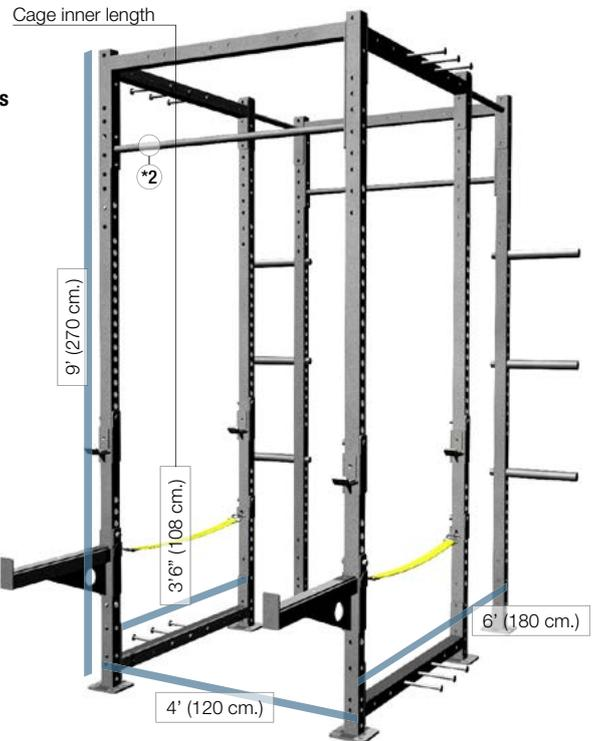

VSSQST01 Heavy Duty Squat Stand (Pair of Bar J-Rack included)

WEIGHT (Kg./Lbs)	L (cm.)	W (cm.)	H (cm.)
50 / 110	120	130	180

- Material: Powder coated steel - Color: Matte Black
- Steel tubes size: 60x60x3.5 mm.

*1

⚠ Bar and plates are sold as separate



STATIONS FOR WEIGHT AND POWER LIFTING

VSAXFIT09 XRIG™ - Safety Spotter Arm

WEIGHT (Kg./Lbs)	L (cm.)	W (cm.)	H (cm.)
20 / 44	66	9	29

- Material: Powder coated steel - Color: Matte Black Steel tubes
- Max load: 500 Kg.
- Steel tubes size: 60x60x3.5 mm.

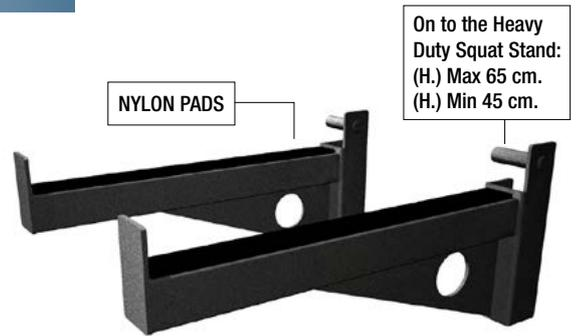

VSAXFIT10 XRIG™ - Plates Storage Sleeve

WEIGHT (Kg./Lbs)	L (cm.)	W (cm.)	H (cm.)
4 / 9	43	6.5	14

- Material: Powder coated steel - Color: Matte Black Steel tubes
- Max load: 300 Kg.
- Steel tube diameter: 48 mm.

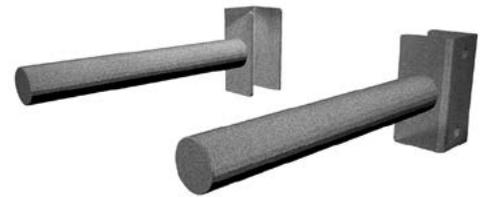

VSBDPG01 Heavy Duty Squat Stand option - Band Pegs (6 pcs)

- Material: Steel - Finishing: Chromed



VSYKSD01 Heavy Duty Squat Stand option - Yoke & Sleds Plates Support and Sled Skies

- Material: Powder coated steel - Color: Matte Black



VSYSCBAR01 Heavy Duty Squat Stand option - Yoke & Sled Cross-Bar

WEIGHT (Kg./Lbs)	L (cm.)	W (cm.)	H (cm.)
10 / 22	120	6	22

- Material: Powder coated steel - Color: Matte Black
- Diameter: 6 cm.



STATIONS FOR WEIGHT AND POWER LIFTING

VSPUPST01 Heavy Duty Squat Stand option - Pull Up Bar Station

WEIGHT (Kg./Lbs)	L (cm.)	W (cm.)	H (cm.)
20 / 44	120	6	70

- Material: Powder coated steel - Color: Matte Black
- Steel tubes size: 32x4 mm round tubes.

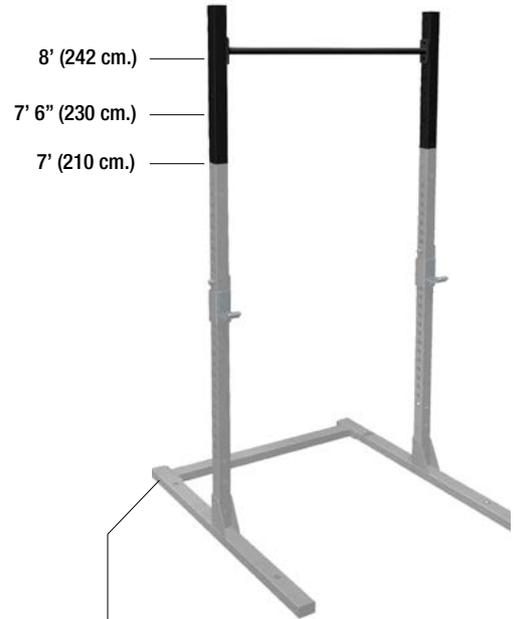

VSWK01 Heavy Duty Squat Stand option - Move-it wheels set



VSSQST02 Portable Squat Stand

WEIGHT (Kg./Lbs)	L (cm.)	W (cm.)	H (cm.)
30 / 66	120	60	180

- Material: Powder coated steel - Color: Matte Black
- Steel tubes size: 60x60x3.5 mm.
- Max load: 500 Kg



VSFTBC01 Heavy Duty Utility Flat Bench

WEIGHT (Kg./Lbs)	L (cm.)	W (cm.)	H (cm.)
25 / 55	120	34	45

- (Bench) Material: PVC Coated foam w/ plywood core - Color: Black
- (Steel Frame) Material: Powder coated steel Color: Matte Black
- Size: 60x60x3.5 Steel Tubes
- Max load body weight: 180 Kg - Max tested: 450 Kg.



WEIGHT AND POWER LIFTING

ONE ITEM = FOUR WORKOUT TOOLS

3 mm. THICK STEEL TUBE
TESTED UP TO 600 lbs (300 kg.)



WEIGHT AND POWER LIFTING

STATIONS FOR WEIGHT AND POWER LIFTING

VSFTBC02 Heavy Duty Utility Adjustable Bench

WEIGHT (Kg./Lbs)	L (cm.)	W (cm.)	H (cm.)
40 / 88	150	60	45

- (Bench) Material: PVC Coated foam w/ plywood core - Color: Black - Size (A): 120(L) x32(W.)x6(Thick.) - Size (B): 30(L)x32(W.)x6(Thick.)
- (Steel Frame) Material: Powder coated steel w/ hard chromed steel plates for adjustable means - Color: Matte Black - Size: 75x75x3.5 cm. steel tubes

EXTRA HARDNESS FOAM FOR HEAVY BODYWEIGHT



WLFTPLT01 Weight Lifting Platform 3x2 m. - Bamboo Workout Platform

WEIGHT (Kg./Lbs)	L (cm.)	W (cm.)	H (cm.)
140 / 309	305	208.8	3

- Wood-Core Rubber Tiles (200x100x3 cm. each)
- Bamboo-Wood Platform (200x100x3 cm.)
- 3x3 cm. steel rim

SPECIAL 3 cm. THICKNESS WOOD-CORE RUBBER TILES. TO REDUCE AND CONTROL BARS BOUNCES.

CUSTOM LOGO AVAILABLE ON DEMAND



EXTRA HARDNESS BAMBOO WORKOUT PLATFORM - 3 cm. THICKNESS

LOGOCUSWLP Logo Custom for Weight Lifting Wood Platform - 60x48 (1 color)

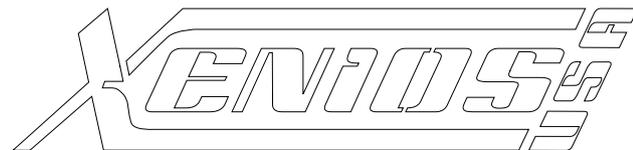

WLFTPLT02 Weight Lifting Echo-Platform

WEIGHT (Kg./Lbs)	L (cm.)	W (cm.)	H (cm.)
170 / 375	306	206	3

- Interlocking Pins Rubber Tiles (100x100x3 cm. each)
- 3x3 cm. steel rim



3 cm. THICKNESS RUBBER TILES.

CUSTOM LOGO AVAILABLE ON DEMAND



WEIGHT AND POWER LIFTING

WEIGHT AND POWER LIFTING TOOLS

RK0BAJSD02 Wood Jerk Blocks - 3 stackable elements set (pair) - 40/30/15/6 cm.

WEIGHT (Kg./Lbs)	L (cm.)	W (cm.)	H (cm.)
140 / 308	91	51	91

- Material: Pine plywood - Color: light wood
 - 45/30/15/6 cm. - Top w/safety edges and antiskid rubber coating - 91x51 cm. foot print

RK0BAJSD03 Wood Jerk Block - 91x51x40 (H) cm. Element - Safety Edges Equipped Top

WEIGHT (Kg./Lbs)	L (cm.)	W (cm.)	H (cm.)
35 / 77	91	51	40

- Material: Pine plywood - Color: light wood

RK0BAJSD04 Wood Jerk Block - 91x51x30 (H) cm. Element - Safety Edges Equipped Top

WEIGHT (Kg./Lbs)	L (cm.)	W (cm.)	H (cm.)
20 / 44	91	51	30

- Material: Pine plywood - Color: light wood

RK0BAJSD05 Wood Jerk Block - 91x51x15 (H) cm. Element - Safety Edges Equipped Top

WEIGHT (Kg./Lbs)	L (cm.)	W (cm.)	H (cm.)
10 / 22	91	51	15

- Material: Pine plywood - Color: light wood

RK0BAJSD06 Wood Jerk Block - 91x51x6 (H) cm. Element - Safety Edges Equipped Top (coated w/anti-skid rubber)

WEIGHT (Kg./Lbs)	L (cm.)	W (cm.)	H (cm.)
5 / 11	91	51	6

- Material: Pine plywood - Color: light wood



WEIGHT AND POWER LIFTING TOOLS

XSBRJK01 Barbell-Jack

WEIGHT (Kg./Lbs)	L (cm.)	W (cm.)	H (cm.)
5 / 11	65	8	34

⚠ Bar and plate are not included



STRONGMAN GEAR



STRONGMAN RUBBER HEX DUMBBELLS

HRBDB55 Strongman Black Rubber Hex Dumbbell w/ contoured handle - 55 Kg.

HRBDB60 Strongman Black Rubber Hex Dumbbell w/ contoured handle - 60 Kg.

HRBDB65 Strongman Black Rubber Hex Dumbbell w/ contoured handle - 65 Kg.

HRBDB70 Strongman Black Rubber Hex Dumbbell w/ contoured handle - 70 Kg.



SPECIALITY BARS AND TOOLS

LOGBAR02 51" Black Coated Strongman Short Log Bar

WEIGHT (Kg./Lbs)	L (cm.)	W (cm.)	H (cm.)
30 / 66	128	23	23

- 150 Kg./330 Lbs max. load
- Material: Powder coated steel - Color: matte black

⚠ Plates are not included.
⚠ All Xenios USA® bars are not pre-equipped with collars.

EQUIPPED WITH
A PAIR OF STEEL COLLARS



PRSTRGLOGBAR01 Pro-Strongman Training Log Bar - Black Powder Coated

WEIGHT (Kg./Lbs)	L (cm.)	W (cm.)	H (cm.)
35 / 77	185	22	36

- 200 Kg./450 Lbs max. load
- Material: Powder coated steel - Color: matte black

⚠ All Xenios USA® bars are not pre-equipped with collars.



PRSTRGLOGBAR02 Pro-Strongman Contest Log Bar (Super Light) - Zinc Plated

WEIGHT (Kg./Lbs)	L (cm.)	W (cm.)	H (cm.)
40 / 88	160	32	20

- 300 Kg./661 Lbs max. load
- Material: Zinc Plated - Color: color zinc

⚠ All Xenios USA® bars are not pre-equipped with collars.



PRSTRGLOGBAR03 Pro-Strongman Contest Log Bar - Black Powder Coated

WEIGHT (Kg./Lbs)	L (cm.)	W (cm.)	H (cm.)
72 / 158	200	30	25

- 350 Kg./771 Lbs max. load
- Material: Powder coated steel - Color: matte black

⚠ All Xenios USA® bars are not pre-equipped with collars.



SPECIALITY BARS AND TOOLS

FRWK01 59" Black Coated Farmer Walk Bars

WEIGHT (Kg./Lbs)	L (cm.)	W (cm.)	H (cm.)
14 / 31	150	7	19

- 7 kg. each
- 100 Kg./220 Lbs max. load each
- Material: Powder coated steel - Color: matte black

⚠ All Xenios USA® bars are not pre-equipped with collars.



FRWK02 59" Black Coated Strongmen Farmer Walk Bars

WEIGHT (Kg./Lbs)	L (cm.)	W (cm.)	H (cm.)
42 / 92	153	7	19

- 21 kg. each
- 150 Kg./300 Lbs max. load each
- Material: Powder coated steel - Color: matte black

⚠ Plates are not included.

⚠ All Xenios USA® bars are not pre-equipped with collars.



PRSTRFRWK01 Pro-Strongman Training Farmer Walk Bars w/adjustable grips

WEIGHT (Kg./Lbs)	L (cm.)	W (cm.)	H (cm.)
32 / 70	120	20	60

- 16 kg. each
- 150 Kg./300 Lbs max. load each
- Material: Powder coated steel - Color: matte black

⚠ All Xenios USA® bars are not pre-equipped with collars.



PRSTRFRWK02 Pro-Strongman Farmer Walk Bars Zinc Plated

WEIGHT (Kg./Lbs)	L (cm.)	W (cm.)	H (cm.)
40 / 88	100	16	42

- 20 kg. each
- 250 Kg./551 Lbs max. load each
- Material: zinc plated - Color: color zinc

⚠ All Xenios USA® bars are not pre-equipped with collars.



PRSTRFRWK03 Pro-Strongman Contest Farmer Walk Bars

WEIGHT (Kg./Lbs)	L (cm.)	W (cm.)	H (cm.)
90 / 198	150	20	60

- 45 kg. each
- 350 Kg./771 Lbs max. load each
- Material: Powder coated steel - Color: matte black

⚠ All Xenios USA® bars are not pre-equipped with collars.

PSO0BAR01 86" Chromed finish Oversize Olympic Bar

WEIGHT (Kg./Lbs)	L (cm.)
32 / 70	220

- 500 Kg./1100 Lbs max. load - Material: Steel - Finishing: Chromed

⚠ All Xenios USA® bars are not pre-equipped with collars.



PSO0BAR02 47" Chromed finish Oversize Olympic Bar

WEIGHT (Kg./Lbs)	L (cm.)
15 / 33	120

- 200 Kg./450 Lbs max. load - Material: Steel - Finishing: Chromed

⚠ All Xenios USA® bars are not pre-equipped with collars.



STRONGMEN GEAR

PSAXLBAR01 82.6" Black Coated Long Axle

WEIGHT (Kg./Lbs)	L (cm.)
12 / 26	210

- 300 Kg./660 Lbs max. load
- Can fit gym racks
- Material: Powder coated steel - Color: matte black
- Grip diameter: 50 mm

⚠ All Xenios USA® bars are not pre-equipped with collars.



PSAXLBAR02 60" Black Coated Short Axle

WEIGHT (Kg./Lbs)	L (cm.)
9 / 20	152

- 150 Kg./330 Lbs max. load
- Material: Powder coated steel - Color: matte black
- Grip diameter: 50 mm

⚠ All Xenios USA® bars are not pre-equipped with collars.

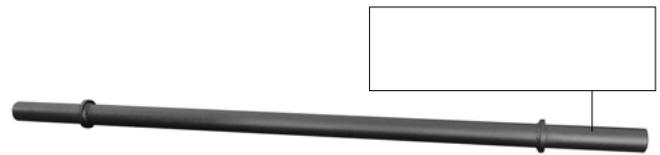

PSOQBAR03 63"x24"x24" Olympic Strongman Hexagonal Bar w/double grip

WEIGHT (Kg./Lbs)	L (cm.)	W (cm.)	H (cm.)
38 / 84	160	64	-

- 450 Kg./1000 Lbs max. load
- Material: Steel - Finishing: NP plated
- Grip diameter: 32 mm

⚠ All Xenios USA® bars are not pre-equipped with collars.

XSBRJK01 Barbell-Jack

WEIGHT (Kg./Lbs)	L (cm.)	W (cm.)	H (cm.)
5 / 11	65	8	34

⚠ Bar and plate are not included

STRONGMAN EVOLUTION CAST-IRON KETTLEBELLS

PSCIKBLH56 Strongman Evolution Black Powder Coated Cast Iron Kettlebell - 56 Kg.

PSCIKBLH68 Strongman Evolution Black Powder Coated Cast Iron Kettlebell - 68 Kg.

PSCIKBLH80 Strongman Evolution Black Powder Coated Cast Iron Kettlebell - 80 Kg.

PSCIKBLH92 Strongman Evolution Black Powder Coated Cast Iron Kettlebell - 92 Kg.



STRONGMAN GEAR

STRONGMAN MED BALLS

PSBCSBL14-30	14" Strongman Med Ball - 30 Kg. (65 Lbs - 35 cm.)
PSBCSBL14-40	14" Strongman Med Ball - 40 Kg. (90 Lbs - 35 cm.)
PSBCSBL14-50	14" Strongman Med Ball - 50 Kg. (110 Lbs - 35 cm.)
PSBCSBL14-60	14" Strongman Med Ball - 60 Kg. (130 Kbs - 35 cm.)
PSBCSBL14-70	14" Strongman Med Ball - 70 Kg. (150 Lbs - 35 cm.)
PSBCSBL14-80	14" Strongman Med Ball - 80 Kg. (180 Kbs - 35 cm.)
PSBCSBL14-90	14" Strongman Med Ball - 90 Kg. (200 Lbs - 35 cm.)
PSBCSBL14-100	14" Strongman Med Ball - 100 Kg. (220 Lbs - 35 cm.)



ATLAS STONES

VSATST10	8" Atlas Stone - (20 cm. dia.) - 23 Lbs (10 Kg.) approx.
VSATST20	10" Atlas Stone - (25 cm. dia.) - 42 Lbs (19 Kg.) approx.
VSATST30	12" Atlas Stone - (30 cm. dia.) - 72 Lbs (32 Kg.) approx.
VSATST50	14" Atlas Stone - (35 cm. dia.) - 116 Lbs (52 Kg.) approx.
VSATST80	16" Atlas Stone - (40 cm. dia.) - 175 Lbs (80 Kg.) approx.
VSATST100	18" Atlas Stone - (45 cm. dia.) - 240 Lbs (110 Kg.) approx.
VSATSTMD10	Mold for 8" Atlas Stone - (20 cm. dia.) - 23 Lbs (10 Kg.) approx.
VSATSTMD20	Mold for 10" Atlas Stone - (25 cm. dia.) - 42 Lbs (19 Kg.) approx.
VSATSTMD30	Mold for 12" Atlas Stone - (30 cm. dia.) - 72 Lbs (32 Kg.) approx.
VSATSTMD50	Mold for 14" Atlas Stone - (35 cm. dia.) - 116 Lbs (52 Kg.) approx.
VSATSTMD80	Mold for 16" Atlas Stone - (40 cm. dia.) - 175 Lbs (80 Kg.) approx.
VSATSTMD100	Mold for 18" Atlas Stone - (45 cm. dia.) - 240 Lbs (110 Kg.) approx.



MOLD FOR ATLAS STONE



COMING SOON

GRIP TRAINING GEAR

VSGPSG01	Strongmen Spring - 100 Lbs (50 Kg.)
VSGPSG02	Strongmen Spring - 200 Lbs (100 Kg.)
VSGPSG03	Strongmen Spring - 300 Lbs (150 Kg.)



VSAXFIT52 XRIG™ - 12" Strongmen Pull-Up Globe w/carabiner and strap

WEIGHT (Kg./Lbs)	Dia. (cm.)
5.8 / 12.7	30

- Material: Powder coated steel - Color: Matte black - Carabiner and Strap included

VSAXFIT55 XRIG™ - 3" Strongmen Pull-Up Marble w/carabiner and strap

WEIGHT (Kg./Lbs)	Dia. (cm.)
1.8 / 4	8

- Material: Powder coated steel - Color: Matte black - Carabiner and Strap included

VSAXFIT53 XRIG™ - 5" Strongmen Pull-Up Marble

WEIGHT (Kg./Lbs)	Dia. (cm.)
1.2 / 2.6	13

- Material: Powder coated steel - Color: Matte black - Carabiner and Strap included

VSAXFIT54 XRIG™ - 3" Strongmen Pull-Up Marble

WEIGHT (Kg./Lbs)	Dia. (cm.)
1.2 / 2.6	8

- Material: Powder coated steel - Color: Matte black - Carabiner and Strap included



12"

3"



5"

3"



STATIONS FOR WEIGHT AND POWER LIFTING



RKXFIT17MS MAGNUM SERIES - XRIG™ - Big Boy Rack 4'x 6' x 9' (122 cm. x 182 cm. x 270 cm.) - w/ Power Lifting Cage

- MAGNUM SERIES - XRIG™ - 9' Basic Upright (270 cm.) - 3.15" x 3.15" x 8 Gauge (8 x 8cm. x 4mm.) Oversize Steel Tube - x6PCs
- XRIG™ - 4' Basic Pull-Up frame (104 cm.) - M.S. (to be used with Magnum Series Rack) x2PCs
- XRIG™ - Power Bands Pegs Cross Member (to be used with Power Lifting Cage) x4PCs
- XRIG™ - Back Cross Member - M.S. (to be used with RKXFIT17MS - BIG BOY - POWER LIFTING CAGE) x2PCs
- XRIG™ - Plates Sleeve - M.S. (to be used with Magnum Series Uprights) x6PCs
- MAGNUM SERIES - XRIG™ - Safety Strap Anchoring Tool - 8 Gauge (4 mm. steel thickness) x2PCs
- XRIG™ - 2"x55" Nylon Safety Strap w/HD Carabiner (Max.Load 1200 Kg.) (for XRIG POWER LIFTING CAGE) x2PCs
- MAGNUM SERIES - XRIG™ - Safety Spotter Arm - 8 Gauge (4 mm. steel thickness) x2PCs
- MAGNUM SERIES - XRIG™ - Bar J-Rack - 8 Gauge (4 mm. steel thickness) x4PCs



WEIGHT (Kg./Lbs)	L (cm.)	W (cm.)	H (cm.)
265 / 584	122	182	270

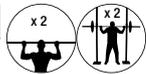

- Material: Powder coated steel - Color: Matte black
- Steel tubes size: 80x80x4 mm. + 32x4 mm. round tubes.

⚠ Should you get an XFIT Rack already, it can be upgraded to the Powerlifting Cage by using the "Powerlifting Cage-rack upgrade kit (VSXFIT17)".

- *2 - Pull-Up heights: 6'10"-7'6"-8'3" (only w/12' Uprights)
- Can be switched with: Double Cross Member (VSXFIT22/23)/Muscle-Up (VSXFIT28/21/36/37) /Offset Pull-Up Frame (VSXFIT01/06)/Offset Pull-Up Bar (VSXFIT35/36)
- Pull-Up heights: 8'74"-6'10"

XRIG™ configurations come disassembled.



VSSQST01MS MAGNUM SERIES - Heavy Duty Squat Stand (Bar J-Rack included) - 3.15" x 3.15" x 8 Gauge (8 x 8 cm. x 4 mm.) Oversize Steel Tubes

WEIGHT (Kg./Lbs)	L (cm.)	W (cm.)	H (cm.)
58 / 127	120	130	200

- Material: Powder coated steel
- Color: Matte Black
- Steel tubes size: 80x80x4 mm.

*1

⚠ Bar and plates are sold as separate

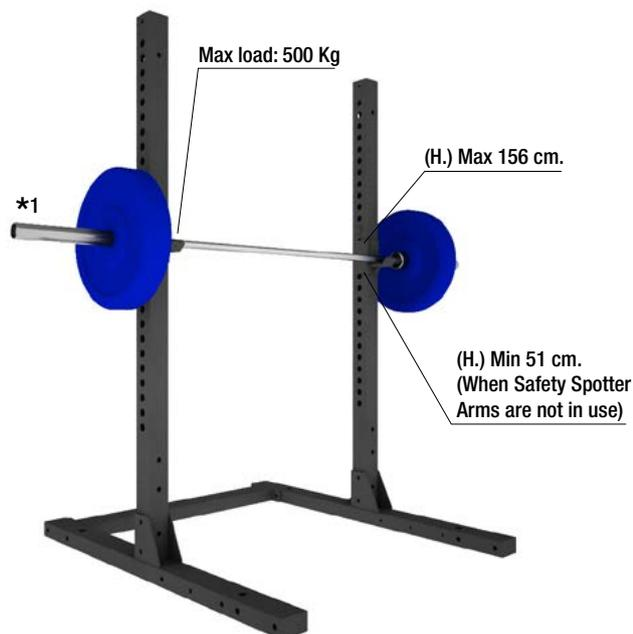

STATIONS FOR WEIGHT AND POWER LIFTING



VSAXFIT09MS **MAGNUM SERIES - Heavy Duty Squat Stand option**
- Safety Spotter Arm - 3.15" x 3.15" x 8 Gauge (8 x 8 cm. x 4 mm.)
Upsize Steel Tubes

WEIGHT (Kg./Lbs)	L (cm.)	W (cm.)	H (cm.)
20 / 45	66	9	29

- Material: Powder coated steel - Color: Matte Black Steel tubes
- Max load: 500 Kg.
- Steel tubes size: 80x80x4 mm.



VSAXFIT10MS **MAGNUM SERIES - Plates Storage Sleeve**

WEIGHT (Kg./Lbs)	L (cm.)	W (cm.)	H (cm.)
10 / 22	43	9	14

- Material: Powder coated steel - Color: Matte Black Steel tubes mm.
- Max load: 300 Kg.
- Steel tube diameter: 48 mm.

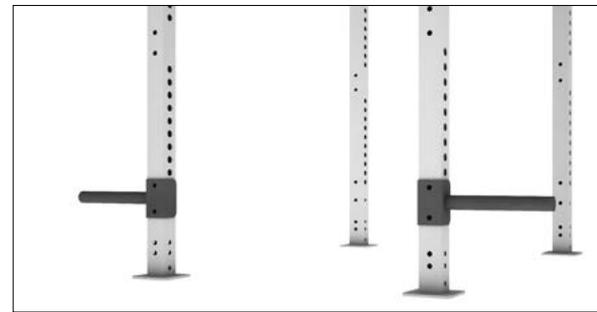

VSYKSD01MS **MAGNUM SERIES - Heavy Duty Squat Stand option**
- Yoke & Sleds: Plates Supports and Sled Skies

- Material: Powder coated steel - Color: Matte Black
- Steel tube diameter: 48 mm.

COMING SOON

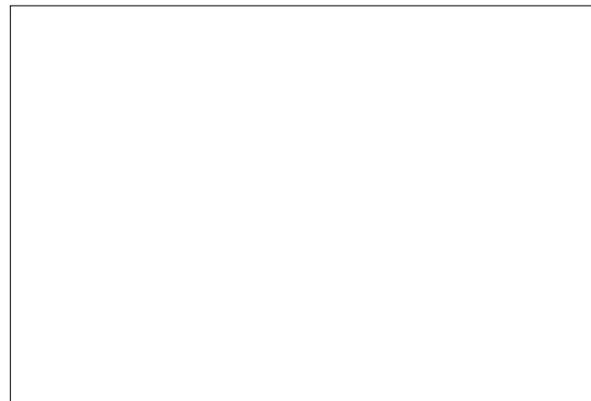

VSYSCBAR01MS **MAGNUM SERIES - Heavy Duty Squat Stand option**
- Yoke & Sled Cross-Bar

WEIGHT (Kg./Lbs)	L (cm.)	W (cm.)	H (cm.)
10 / 22	120	6	22

- Material: Powder coated steel - Color: Matte Black
- Diameter: 5 cm.

COMING SOON

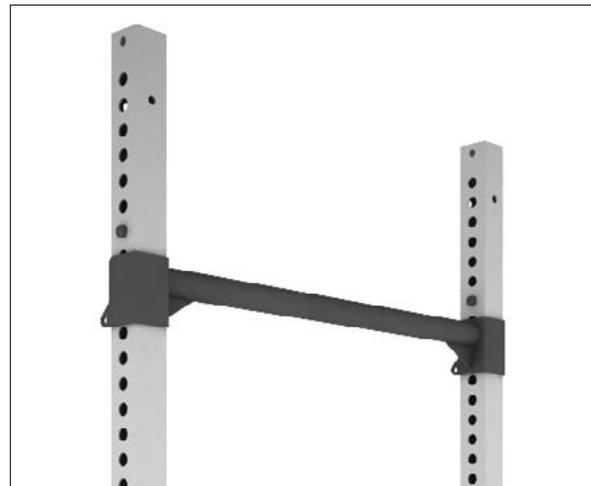

STATIONS FOR WEIGHT AND POWER LIFTING



VSPUPST01MS MAGNUM SERIES - Heavy Duty Squat Stand option - Pull Up Bar Station - Oversize Steel Tubes

WEIGHT (Kg./Lbs)	L (cm.)	W (cm.)	H (cm.)
22 / 48	120	8	70

- Material: Powder coated steel - Color: Matte Black
- Max load: 300 Kg.
- Steel tubes size: 80x80x4 mm.

COMING SOON

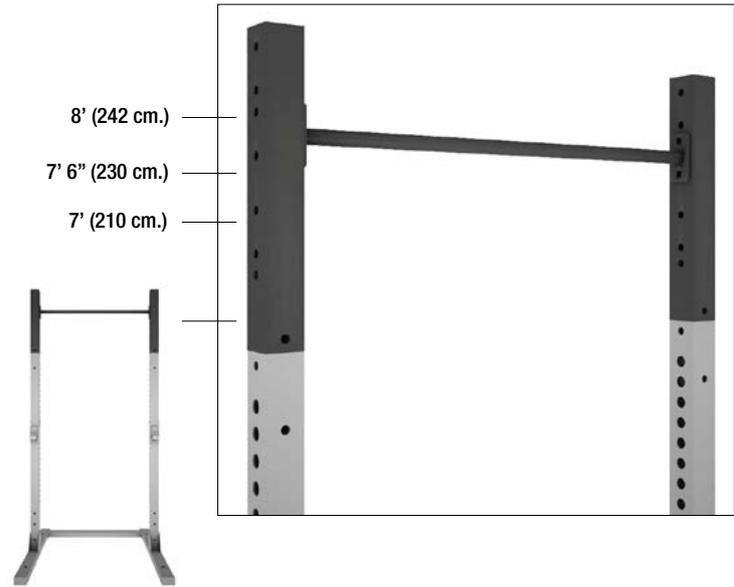

VSFTBC01MS MAGNUM SERIES - Heavy Duty Utility Flat Bench - Oversize Steel Tubes

WEIGHT (Kg./Lbs)	L (cm.)	W (cm.)	H (cm.)
35 / 77	120	34	45

- (Bench) Material: PVC Coated foam w/ plywood core - Color: Black
- (Steel Frame) Material: Powder coated steel Color: Matte Black
- Size: 80x80x4 Steel Tubes

COMING SOON

EXTRA HARDNESS FOAM FOR HEAVY BODYWEIGHT



VSSMYKSLD01MS MAGNUM SERIES - Strongmen Yoke and Sled - Oversize Steel Tubes

- MAGNUM SERIES - Heavy Duty Squat Stand (Bar J-Rack inclusi) - 3.15" x 3.15" x 8 Gauge (8 x 8 cm. x 4 mm.) Oversize Steel Tubes - x1KIT
- MAGNUM SERIES - Heavy Duty Squat Stand option - Yoke & Sleds: Plates Supports and Sled Skies - 8 Gauge (4 mm. steel thickness) - x1SET
- MAGNUM SERIES - Heavy Duty Squat Stand option - Yoke & Sled Cross-Bar - 8 Gauge (4 mm. steel thickness) x1PCs

WEIGHT (Kg./Lbs)	L (cm.)	W (cm.)	H (cm.)
65 / 143	120	130	200

- Material: Powder coated steel - Color: Matte Black
- Steel tubes size: 80x80x4 mm.

COMING SOON



concept 2
INDOOR ROWER



CARDIO ENDURANCE

CE RoHS

CONCEPTDPM5 Rower Concept2 Mod. D - (w/PM5 monitor)

WEIGHT (Kg./Lbs)	L (cm.)	W (cm.)	H (cm.)
28 / 62	240	60	122

- Also available w/ PM 5 Monitor
- Material: steel - Color: grey



CONCEPTDPM4 Rower Concept2 Mod. D - (w/ PM4 monitor)

WEIGHT (Kg./Lbs)	L (cm.)	W (cm.)	H (cm.)
28 / 62	240	60	122

- Also available w/ PM 4 Monitor
- Material: steel - Color: grey



CE RoHS

CONCEPTDBPM5 Rower Concept2 Mod. D - Black Edition (w/PM5 monitor)

WEIGHT (Kg./Lbs)	L (cm.)	W (cm.)	H (cm.)
28 / 62	240	60	122

- Also available w/ PM 5 Monitor
- Material: steel - Color: black



CONCEPTDBPM4 Rower Concept2 Mod. D - Black Edition (w/ PM4 monitor)

WEIGHT (Kg./Lbs)	L (cm.)	W (cm.)	H (cm.)
28 / 62	240	60	122

- Also available w/ PM 4 Monitor
- Material: steel - Color: black



CE RoHS

CONCEPT E Rower Concept2 Mod. E (w/PM4 monitor)

WEIGHT (Kg./Lbs)	L (cm.)	W (cm.)	H (cm.)
28 / 62	240	60	122

- Material: steel - Color: grey



* CONCEPT2® is a Patented Invention and a Patented Design and a Registered Trademark owned by and used under license from Concept2 Inc. - VT(USA)



CARDIO ENDURANCE

CARDIO ENDURANCE

SKIERG **SkiErg Concept2 - M.Y. 2015 - Wall Mounted** **CE RoHS**

WEIGHT (Kg./Lbs)	L (cm.)	W (cm.)	H (cm.)
20.9 / 46	52	48	212

- Material: steel - Color: black



SKIERGFS **SkiErg Concept2 - M.Y. 2015 - Floor Stand Option** **CE RoHS**

WEIGHT (Kg./Lbs)	L (cm.)	W (cm.)	H (cm.)
16 / 35	61	132	90

- Material: steel - Color: black



* CONCEPT2® is a Patented Invention and a Patented Design and a Registered Trademark owned by and used under license from Concept2 Inc. - VT(USA)



CARDIO ENDURANCE

ASSAULTBK Assault Air Bike

WEIGHT (Kg./Lbs)	L (cm.)	W (cm.)	H (cm.)
45 / 99	130	60	123

- Material: steel - Color: black
- Max user bodyweight: 160 kg.

ASSAULT AIR BIKE



ASSAULTBKWDSC Assault Airbike Option - Wind Screen

ASSAULT AIR BIKE



Assault Bike® is a registered trademark owned by and used under license from Lifecore Fitness Inc. (USA)



FIGHTER TRAINING

PSNYFGT01 Fighter Belt w/rings - Small



PSNYFGT02 Fighter Belt w/rings - Large

PSNYFGT03 Fighter Ankle Cuff w/ring



PSNYFGT04 Fighter Wrist Cuff w/ring and thumb hook

PSFTGKIT01 Fighter Kit Small - Light

- 12" Green Nylon Encased Multi-use Elastic Tube - Light - x2PCs
- 14" Green Nylon Encased Multi-use Elastic Tube - Light - x2PCs
- Fighter Ankle Cuff w/ring - x2PCs
- Fighter Wrist Cuff w/ring and thumb hook - x2PCs
- Fighter Belt w/rings - Small - x1PC



PSFTGKIT02 Fighter Kit Large - Light

- 12" Green Nylon Encased Multi-use Elastic Tube - Light - x2PCs
- 14" Green Nylon Encased Multi-use Elastic Tube - Light - x2PCs
- Fighter Ankle Cuff w/ring - x2PCs
- Fighter Wrist Cuff w/ring and thumb hook - x2PCs
- Fighter Belt w/rings - Large - x1PC

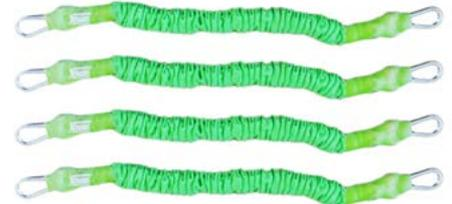

PSFTGKIT03 Fighter Kit Small - Heavy

- 12" Blue Nylon Encased Multi-use Elastic Tube - Heavy - x2PCs
- 14" Blue Nylon Encased Multi-use Elastic Tube - Heavy - x2PCs
- Fighter Ankle Cuff w/ring - x2PCs
- Fighter Wrist Cuff w/ring and thumb hook - x2PCs
- Fighter Belt w/rings - Small - x1PC



PSFTGKIT04 Fighter Kit Large - Heavy

- 12" Blue Nylon Encased Multi-use Elastic Tube - Heavy - x2PCs
- 14" Blue Nylon Encased Multi-use Elastic Tube - Heavy - x2PCs
- Fighter Ankle Cuff w/ring - x2PCs
- Fighter Wrist Cuff w/ring and thumb hook - x2PCs
- Fighter Belt w/rings - Large - x1PC



PSFTKITP01 Pro Fighter Kit - Light

- 51" Green Nylon Encased Multi-use Elastic Tube - Light - x4PCs
- Fighter Ankle Cuff w/ring - x2PCs
- Fighter Wrist Cuff w/ring and thumb hook - x2PCs
- Anchoring Steel Ring w/steel heavy duty carabiner - x1PC



PSFTKITP03 Pro Fighter Kit - Heavy

- 51" Blue Nylon Encased Multi-use Elastic Tube - Heavy - x4PCs
- Fighter Ankle Cuff w/ring - x2PCs
- Fighter Wrist Cuff w/ring and thumb hook - x2PCs
- Anchoring Steel Ring w/steel heavy duty carabiner - x1PC



PSSTKIT01 Striker Kit - Light

- Striker Shoulder Harness - x1PC
- Green Striker Elastic Tube - Light - x1PC
- Fighter Wrist Cuff w/ring and thumb hook - x2PCs



PSSTKIT03 Striker Kit - Heavy

- Striker Shoulder Harness - x1PC
- Blue Striker Elastic Tube - Heavy - x1PC
- Fighter Wrist Cuff w/ring and thumb hook - x2PCs



WORKOUT GEAR

WORKOUT GEAR

GTPPXNS Goat Tape® - Xenios USA® - 1.5" x 10 Yard Roll (4 cm. x 9 m.)



XSCKBK01 Chalk Brick - 56 gr. each brick Box: 8 pcs



PSNYCLAT007 Dead Lift Straps 1.5" x 23" **COMING SOON**



PSNYCLAT008 Dead Lift Power Hooks **COMING SOON**



PSWRST01 Wrist strap Black/Blue - 8 x 39 cm. - Elastic - Velcro end



PSWRST02 Wrist strap Pink/Blue - 8 x 39 cm. - Elastic - Velcro end



PSWRST03 Wrist strap Grey/Blue - 8 x 39 cm. - Elastic - Velcro end



PSWRST04 Wrist strap Blue/White - 8 x 39 cm. - Elastic - Velcro end

COMING SOON



WORKOUT GEAR

PSKNSTR01 Strongman Knee Strap - 8 cm. x 200 cm. - Elastic - Black/Blue

PSKNSTR02 Strongman Knee Strap - 8 cm. x 250 cm. - Elastic - Black/Blue

COMING SOON



PSNYKNGD01/2/3 High Compression (6 mm.) Neoprene Knee-gard
- Size S/M/L



PSNYKNGD04/05/08 Compression Neoprene (5 mm.) Knee-gard
- XS/S/M - Pink



PSNYKNGD09/06/07 Compression Neoprene (5 mm.) Knee-gard
- XS/S/M - Blue



PSNYKNGD10/11/12 Compression Neoprene (5 mm.) Knee-gard
- XS/S/M - Army Green Camo



PSNYKNGD13/14/15 Compression Neoprene (5 mm.) Knee-gard
- XS/S/M - Purple Zebra



WORKOUT GEAR

PSNYPLAT011 4" Man Ergo WOD Belt - S (89 cm.) - Black/Navy Blue



PSNYPLAT012 4" Man Ergo WOD Belt - M (100 cm.) - Black/Navy Blue



PSNYPLAT013 6" Man Ergo Weight Lifting Belt - S (89 cm.) - Black

PSNYPLAT014 6" Man Ergo Weight Lifting Belt - M (100 cm.) - Black

PSNYPLAT015 4" Woman Ergo WOD Belt - XS (80 cm.) - Black/Pink



PSNYPLAT016 4" Woman Ergo WOD Belt - S (89 cm.) - Black/Pink

REHB7751XS/-/XXL Rehband SBR/Neoprene (5 mm.) Knee-Gard - Size XS/S/M/L/XL/XXL

- Grey/Black - Size XS (Knee Circ. 31-33 cm.)
- Grey/Black - Size S (Knee Circ. 33-35 cm.)
- Grey/Black - Size M (Knee Circ. 35-37 cm.)
- Grey/Black - Size L (Knee Circ. 37-40 cm.)
- Grey/Black - Size XL (Knee Circ. 40-43 cm.)
- Grey/Black - Size XXL (Knee Circ. 43-46 cm.)



REHB7754XS/-/XXL Rehband SBR/Neoprene (5 mm.) Open Patella Knee-Gard - Size XS/S/M/L/XL/XXL

- Grey/Black - Size XS (Knee Circ. 31-33 cm.)
- Grey/Black - Size S (Knee Circ. 33-35 cm.)
- Grey/Black - Size M (Knee Circ. 35-37 cm.)
- Grey/Black - Size L (Knee Circ. 37-40 cm.)
- Grey/Black - Size XL (Knee Circ. 40-43 cm.)
- Grey/Black - Size XXL (Knee Circ. 43-46 cm.)



REHB7710SM-R Rehband SBR/Neoprene (5 mm.) Wrist Support

- Grey/Black - Size S/M (Wrist Circ. 14-18 cm.) - Right Hand

REHB7710LXL-R Rehband SBR/Neoprene (5 mm.) Wrist Support

- Grey/Black - Size L/XL (Wrist Circ. 18-22 cm.) - Right Hand

REHB7710SM-L Rehband SBR/Neoprene (5 mm.) Wrist Support

- Grey/Black - Size S/M (Wrist Circ. 14-18 cm.) - Left Hand

REHB7710LXL-L Rehband SBR/Neoprene (5 mm.) Wrist Support

- Grey/Black - Size L/XL (Wrist Circ. 18-22 cm.) - Left Hand



Rehband® is a registered trademark owned by and used under license from Rehband Anatomiska AB Corp. (SWEDEN)



WORKOUT GEAR

REHB7720XS/-/XXL Rehband SBR/Neoprene (5 mm.) Elbow Sleeve - Size XS/S/M/L/XL/XXL

- Grey/Black - Size XS (Elbow Circ. 22-24 cm.)
- Grey/Black - Size S (Elbow Circ. 24-26 cm.)
- Grey/Black - Size M (Elbow Circ. 26-28 cm.)
- Grey/Black - Size L (Elbow Circ. 28-30 cm.)
- Grey/Black - Size XL (Elbow Circ. 30-32 cm.)
- Grey/Black - Size XXL (Elbow Circ. 32-34cm.)



REHB7790S/-/XXL Rehband SBR/Neoprene (5 mm.) Strongman Knee-Gard - Size S/M/L/XL/XXL

- Grey/Black - w/velcro straps - Size S (Knee Circ. 33-35 cm.)
- Grey/Black - w/velcro straps - Size M (Knee Circ. 35-37 cm.)
- Grey/Black - w/velcro straps - Size L (Knee Circ. 37-40 cm.)
- Grey/Black - w/velcro straps - Size XL (Knee Circ. 40-43 cm.)
- Grey/Black - w/velcro straps - Size XXL (Knee Circ. 43-46 cm.)



REHB7782S/-/XXL Rehband SBR/Neoprene (5 mm.) Strongman Open Patella Knee-Gard - Size S/M/L/XL/XXL

- Grey/Black - w/velcro straps - Size S (Knee Circ. 33-35 cm.)
- Grey/Black - w/velcro straps - Size M (Knee Circ. 35-37 cm.)
- Grey/Black - w/velcro straps - Size L (Knee Circ. 37-40 cm.)
- Grey/Black - w/velcro straps - Size XL (Knee Circ. 40-43 cm.)
- Grey/Black - w/velcro straps - Size XXL (Knee Circ. 43-46 cm.)

REHB7793S-R/-/XL-R Rehband SBR/Neoprene (5 mm.) Strongman Wrist Support - Right Hand - Size S/M/L/XL

- Grey/Black - Size S (Wrist Circ. 15-16,5 cm.)
- Grey/Black - Size S (Wrist Circ. 16,5-18 cm.)
- Grey/Black - Size L (Wrist Circ. 18-19,5 cm.)
- Grey/Black - Size L (Wrist Circ. 19,5-22 cm.)



REHB7793S-L/-/XL-L Rehband SBR/Neoprene (5 mm.) Strongman Wrist Support - Left Hand - Size S/M/L/XL

- Grey/Black - Size S (Wrist Circ. 15-16,5 cm.)
- Grey/Black - Size M (Wrist Circ. 16,5-18 cm.)
- Grey/Black - Size L (Wrist Circ. 18-19,5 cm.)
- Grey/Black - Size XL (Wrist Circ. 19,5-22 cm.)

Rehband® is a registered trademark owned by and used under license from Rehband Anatomiska AB Corp. (SWEDEN)

RKRG01 Rock Guards - Leg Protection for Rope Climbing - S/M size - Black

RKRG02 Rock Guards - Leg Protection for Rope Climbing - L/XL size - Black

RKRG03 Rock Guards - Leg Protection for Rope Climbing - S/M size - Black Manifesto

RKRG04 Rock Guards - Leg Protection for Rope Climbing - L/XL size - Black Manifesto

RKRG05 Rock Guards - Leg Protection for Rope Climbing - S/M size - Lime

RKRG06 Rock Guards - Leg Protection for Rope Climbing - L/XL size - Lime



ROCKTAPE® is Registered Trademark owned by and used under license from Rocktape Inc. - CA (USA)



WORKOUT GEAR

PSMUPGLV01 **Mechanix MAN ORIGINAL VENT[®] - Muscle-Up Tech Gloves - S - Black/Grey**

PSMUPGLV02 **Mechanix MAN ORIGINAL VENT - Muscle-Up Tech Gloves - M - Black/Grey**

PSMUPGLV03 **Mechanix MAN ORIGINAL VENT - Muscle-Up Tech Gloves - L - Black/Grey**

PSMUPGLV04 **Mechanix MAN ORIGINAL VENT - Muscle-Up Tech Gloves - XL - Black/Grey**

PSMUPGLV05 **Mechanix MAN ORIGINAL VENT - Muscle-Up Tech Gloves - XXL - Black/Grey**

PSMUPGLV06 **Mechanix WOMAN ORIGINAL - Muscle-Up Tech Gloves - M - Pink Camo**

PSMUPGLV07 **Mechanix WOMAN ORIGINAL - Muscle-Up Tech Gloves - L - Pink Camo**



RE-HAB AND MOBILITY

RE-HAB AND MOBILITY

VSAXFIT48K

Crossover Workout Kit

- XRIG™ and RACK option - Carabiner Anchoring Tool x2PCs
- 24" Strap anchor w/ring - (60 cm.) x2PCs
- Crossover Workout - 3 Lbs x 47" XLight Elastic Tube w/handle x2PCs
- Length: 120 cm. - Resistance: 1.5 Kg.
- Crossover Workout - 5 Lbs x 47" Light Elastic Tube w/handle x2PCs
- Length: 120 cm. - Resistance: 2.5 Kg.
- Crossover Workout - 7 Lbs x 47" Medium Elastic Tube w/handle x2PCs
- Length: 120 cm. - Resistance: 3,5 Kg.
- Crossoverworkout Kit Nylon Carry Bag x1PC



XSMUEST11

Crossover Workout - 3 Lbs x 47" XLight Elastic Tube

- Length: 100 cm. - Resistance: 1.5 Kg.



XSMUEST12

Crossover Workout - 5 Lbs x 47" Light Elastic Tube

- Length: 100 cm. - Resistance: 2.5 Kg.



XSMUEST13

Crossover Workout - 7 Lbs x 47" Medium Elastic Tube

- Length: 100 cm. - Resistance: 3.5 Kg.



XSMUEST14

Crossover Workout - 12 Lbs x 47" Heavy Elastic Tube w/handle

- Length: 115 cm. - Resistance: 5.5 Kg.



CROSSOVER
WORKOUT™



RE-HAB AND MOBILITY

RE-HAB AND MOBILITY

- XSPTHDRLO4** 36" High Density Foam Full-round Pilates Roller - (90 cm.)
-
- LCRBL-ORANGE** Lacrosse Ball - 5 Oz. X 2.54" - Orange (140 gr. x 6,5 cm. dia.)
-
- LCRBL-BLUE** Lacrosse Ball - 5 Oz. X 2.54" - Blue (140 gr. x 6,5 cm. dia.)
-
- XSLTLPBD16** 9" (23 cm.) Latex Mini Loop Band - Extra Light - Pink
- 2" (5 cm.) width x 0.35 mm. thick
-
- XSLTLPBD17** 9" (23 cm.) Latex Mini Loop Band - Light - Light Blue
- 2" (5 cm.) width x 0.5 mm. thick
-
- XSLTLPBD18** 9" (23 cm.) Latex Mini Loop Band - Medium - Orange
- 2" (5 cm.) width x 0.7 mm. thick
-
- XSLTLPBD19** 9" (23 cm.) Latex Mini Loop Band - Heavy - Purple
- 2" (5 cm.) width x 0.9 mm. thick
-
- XSLTLPBD20** 9" (23 cm.) Latex Mini Loop Band - Extra Heavy - Grey
- 2" (5 cm.) width x 1.2 mm. thick
-



- XSPTLXFLS01** Floss Band 150% - 7' x 2" x 1.2 mm. - Black (208 cm x 5 cm.)
-



BALANCE AND PROPRIOCEPTIVITY

- PSWBCBD01** 16" Wooden Round Balance Board w/anti-slip surface and adjustable angle
- Small (40 cm.)
-
- PSWBCBD02** 18" Wooden Round Balance Board w/anti-slip surface - Medium (45 cm.)
-
- PSWBCBD03** 20" Wooden Round Balance Board w/anti-slip surface - Large (50 cm.)
-
- PSWBCBD04** 20" x 20" Wooden Square Front/Back Balance Board w/anti-slip surface
(50 cm. x 50 cm.)
-
- PSWBCBD05** 24" x 16" Wooden Square Right & Left Balance Board w/anti-slip surface
(60 cm. x 40 cm.)
-
- PSWBCBD06** 24" x 16" Wooden Square Back & Forward Balance Board w/anti-slip surface
(60 cm. x 40 cm.)
-
- PSWBCBDR01** Balance Board Rack - 4 boards
-





 **TRIGGERPOINT[®]**
PERFORMANCE



RE-HAB AND MOBILITY

TRIGGER POINT®

TPGRDX TP - Grid-X - Heavy Duty Roll - Special for Crossfitters (Black/Red)



TPGRDL TP - Grid Lime



TPGRDO TP - Grid Orange



TPGRDC TP - Grid Camo



TPGRDP TP - Grid Pink



TPGRDB TP - Grid Black



TPGRD20 TP - Grid 2.0 Orange



TPGRD2B TP - Grid 2.0 Black



TPGRDMIO TP - Grid Mini Orange

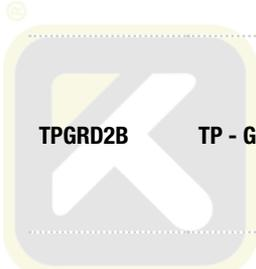

Trigger Point® is a patented design and a register trademark owned by and used under license from Trigger Point Technologies (USA).



RE-HAB AND MOBILITY

TRIGGER POINT®

TPMSGB TP - Massage Ball



TPFCTB TP - Factor Ball for Firmer Massages Black/Red



TPCLDR TP - Cold Roller



TPTBK TP - Total Body Kit

- Footballer x1PC
- QuadBaller x1PC
- TP2 Balls Bag x1PC
- TP Massage Balls x2PCs
- Baller Block x1PC
- Total Body Book x1PC
- DVDs x2PCs



TPSTK TP - Starter Kit

- TP Footballer x1PC
- BallerBlock x1PC
- Massage Ball x1PC



Trigger Point® is a patented design and a register trademark owned by and used under license from Trigger Point Technologies (USA).



ROCK TAPE®

- RKTP01** **Rock Tape Active Recovery - 5 cm. x 5 m. - Black**
- RKTP02** **Rock Tape Active Recovery - 5 cm. x 5 m. - Green**
- RKTP03** **Rock Tape Active Recovery - 5 cm. x 5 m. - Electric Blue**
- RKTP04** **Rock Tape Active Recovery - 5 cm. x 5 m. - Hot Pink**
- RKTP05** **Rock Tape Active Recovery - 5 cm. x 5 m. - Lime Green**
- RKTP06** **Rock Tape Active Recovery - 5 cm. x 5 m. - Navy Blue**
- RKTP07** **Rock Tape Active Recovery - 5 cm. x 5 m. - Purple**
- RKTP08** **Rock Tape Active Recovery - 5 cm. x 5 m. - Black Logo**
- RKTP09** **Rock Tape Active Recovery - 5 cm. x 5 m. - Biohazard**
- RKTP10** **Rock Tape Active Recovery - 5 cm. x 5 m. - Skull**



Go stronger, longer

ROCKTAPE® is Registered Trademark owned by and used under license from Rocktape Inc. - CA (USA)



RE-HAB AND MOBILITY

ROCK TAPE®

RKTP11	Rock Tape Active Recovery - 5 cm. x 5 m. - Pink Skull
RKTP12	Rock Tape Active Recovery - 5 cm. x 5 m. - Blue Argyle
RKTP13	Rock Tape Active Recovery - 5 cm. x 5 m. - Pink Argyle
RKTP14	Rock Tape Active Recovery - 5 cm. x 5 m. - Brown Camo
RKTP15	Rock Tape Active Recovery - 5 cm. x 5 m. - Green Camo
RKTP16	Rock Tape Active Recovery - 5 cm. x 5 m. - Digital Camo
RKTP17	Rock Tape Active Recovery - 5 cm. x 5 m. - Pink Camo
RKTP18	Rock Tape Active Recovery - 5 cm. x 5 m. - Clinical
RKTP19	Rock Tape Active Recovery - 5 cm. x 5 m. - Healthsource
RKTP20	Rock Tape Active Recovery - 5 cm. x 5 m. - Tatoo



ROCKTAPE® is Registered Trademark owned by and used under license from Rocktape Inc. - CA (USA)



ROCK TAPE®

- RKTP21** **Rock Tape Active Recovery - 5 cm. x 5 m. - UK Flag**
- RKTPBK01** **Rock Tape Active Recovery Bulk 5 cm. x 32 m. - Black**
- RKTPBK02** **Rock Tape Active Recovery Bulk 5 cm. x 32 m. - Green**
- RKTPBK03** **Rock Tape Active Recovery Bulk 5 cm. x 32 m. - Electric Blue**
- RKTPBK04** **Rock Tape Active Recovery Bulk 5 cm. x 32 m. - Hot Pink**
- RKTPBK05** **Rock Tape Active Recovery Bulk 5 cm. x 32 m. - Purple**
- RKTPBK06** **Rock Tape Active Recovery Bulk 5 cm. x 32 m. - Lime Green**
- RKTPBK07** **Rock Tape Active Recovery Bulk 5 cm. x 32 m. - Navy Blue**
- RKTPH2001** **Rock Tape Active Recovery H20 (High Resistance) - 5 cm. x 5 m. - Black**
- RKTPH2002** **Rock Tape Active Recovery H20 (High Resistance) - 5 cm. x 5 m. - Electric Blue**



Go stronger, longer



RE-HAB AND MOBILITY

ROCK TAPE®

RKTPH2003 [®] Rock Tape Active Recovery H2O (High Resistance) - 5 cm. x 5 m. - Green



RKTPH2004 Rock Tape Active Recovery H2O (High Resistance) - 5 cm. x 5 m. - Biohazard



RKTPH2005 Rock Tape Active Recovery H2O (High Resistance) - 5 cm. x 5 m. - Blue Argyle



RKTPH2006 Rock Tape Active Recovery H2O (High Resistance) - 5 cm. x 5 m. - Green Camo



RKTPH2007 Rock Tape Active Recovery H2O (High Resistance) - 5 cm. x 5 m. - Pink Camo



RKTPMBD01 Rock Tape Active Recovery Mini Big-Daddy - 10 cm. x 5 m. - Black



RKTPMBD02 Rock Tape Active Recovery Mini Big-Daddy - 10 cm. x 5 m. - Blue



RKTPMBD03 Rock Tape Active Recovery Mini Big-Daddy - 10 cm. x 5 m. - Blue Argyle



RKSC01 Rock Sauce - Pain Reliever Lotion 100 ml.



RKSC02 Rock Sauce - Pain Reliever Lotion 200 ml.



ROCKTAPE® is Registered Trademark owned by and used under license from Rocktape Inc. - CA (USA)



FACILITY OUTFITTING

XSXFITM01 XRIG™ - Interval Training Timer

WEIGHT (Kg./Lbs)	L (cm.)	W (cm.)	H (cm.)
2.5 / 5.8	71	16	4

- Unlimited programmable w/remote control and storable programs
- All WOD programmable - Easy AMRAP function
- Ready for special Tacfit® workout programs
- With remote control - Clock/temperature display
- Wall mounting or desk standing

THE ONLY ONE WITH ADJUSTABLE LOUDNESS OF BEEPER



EXTRA Db. BEEPER



SUNGLASSES SCREEN



REMOTE CONTROL

* Tacfit® is a Registered Trademark used by and under license from RMAX.tv Productions and Secutor S.r.l. - (IT).

XSCKST01 Chalk Station

WEIGHT (Kg./Lbs)	L (cm.)	W (cm.)	H (cm.)
8.5 / 19	50	40	80



XSXFITMAT01 Crash Mat - 6.6' x 3.3' x 2" with handles

WEIGHT (Kg./Lbs)	L (cm.)	W (cm.)	H (cm.)
2 / 4.5	200	100	5

- Anti-slip bottom side - Density 80° - Sanitized "BTEX" Coated - Color: Blue
- Can fit XFit RIG and RACK



XSXFITMAT02 Crash Mat - 6.6' x 3.3' x 8" with handles

WEIGHT (Kg./Lbs)	L (cm.)	W (cm.)	H (cm.)
10 / 22	200	100	20

- Anti-slip bottom side - Density 16° - Sanitized "BTEX" Coated - Color: Blue
- Can fit XFit RIG and RACK



XSXFITMAT03 Crash Mat - 6.6' x 3.3' x 19.5" with handles

WEIGHT (Kg./Lbs)	L (cm.)	W (cm.)	H (cm.)
20 / 44	200	100	50

- Anti-slip bottom side - Density 16° - Sanitized "BTEX" Coated - Color: Blue
- Can fit XFit RIG and RACK



XS RBTBK01 Rubber Tank Block - 24" x 12" x 10"

WEIGHT (Kg./Lbs)	L (cm.)	W (cm.)	H (cm.)
52 / 115	60	30	25

- Color: Black

XS RBTBK02 Rubber Tank Block - 24" x 12" x 10"

WEIGHT (Kg./Lbs)	L (cm.)	W (cm.)	H (cm.)
52 / 115	60	30	25

- Color: Navy blue

XS RBTBK03 Rubber Tank Block - 24" x 12" x 10"

WEIGHT (Kg./Lbs)	L (cm.)	W (cm.)	H (cm.)
52 / 115	60	30	25

- Color: Black - W/interlocking ends

XS RBTBK04 Rubber Tank Block - 24" x 12" x 10" (60 x 30 x 25 cm.)

WEIGHT (Kg./Lbs)	L (cm.)	W (cm.)	H (cm.)
52 / 115	60	30	25

- Color: Navy blue - W/interlocking ends

XS RBTBK05 Rubber Tank Block - Interlocking Pin set

INTERLOCKING PIN OPTION AVAILABLE ON DEMAND



WALL OUTFITTING

WOODB01 OSB Wood Wall Board

WEIGHT (Kg./Lbs)	L (cm.)	W (cm.)	THICK. (mm.)
10 / 22	250	125	15

- Custom logo included

- ⚠ Wall mounting hardware not included.
- ⚠ Parallettes and Abdominal Mat are not included.

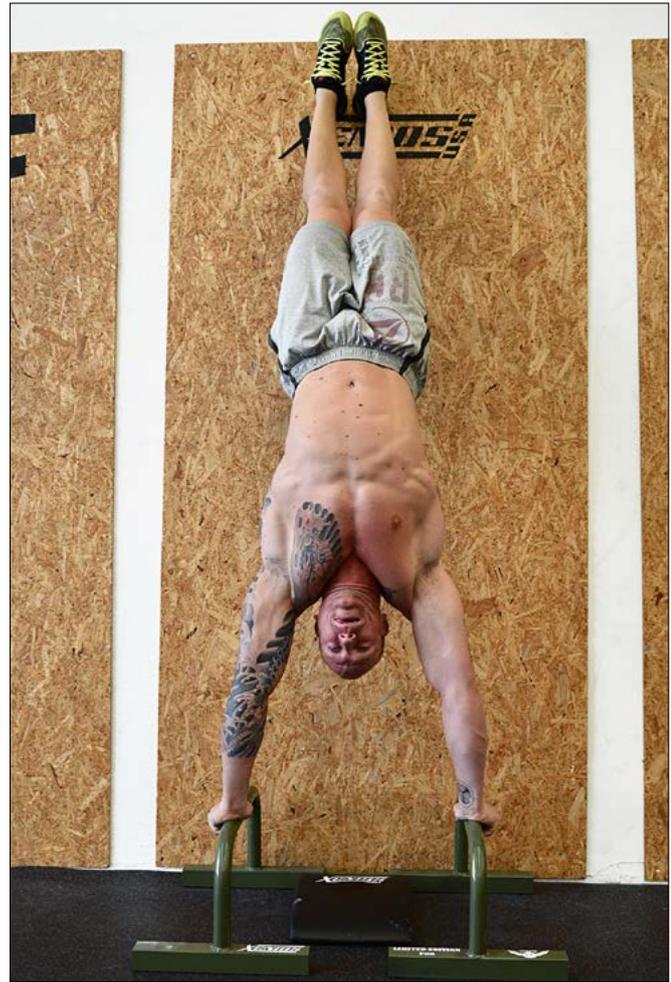

BANNER01 Banner - Xenios USA The Barbell Club

WEIGHT (Kg./Lbs)	L (cm.)	H (cm.)
-	300	100

- Color: white



BANNER03 Banner - Xenios USA

WEIGHT (Kg./Lbs)	L (cm.)	H (cm.)
-	300	100

- Color: navy blue



BANNER02 Banner - Xenios USA

WEIGHT (Kg./Lbs)	L (cm.)	H (cm.)
-	300	100

- Color: white



FACILITY OUTFITTING

WALL OUTFITTING

STENCIL01 Wall Stencil - Xenios USA The Barbell Club

WEIGHT (Kg./Lbs)	L (cm.)	H (cm.)
-	200	200



STENCIL03 Wall Stencil - Xenios USA The Barbell Club

WEIGHT (Kg./Lbs)	L (cm.)	H (cm.)
-	150	150



STENCIL05 Wall Stencil - Wall Ball Target - 45 cm. diam.

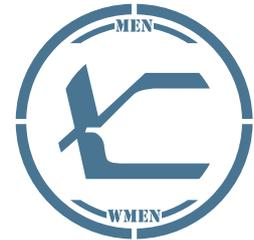

AFBXDSH1.5 Affiliate Box White Dash - 1.5 x 1 m. (L. x H.)

WEIGHT (Kg./Lbs)	L (cm.)	W (cm.)
5/11	150	100

- Color: white

AFBXDSH2.0 Affiliate Box White Dash - 2 x 1 m. (L. x H.)

WEIGHT (Kg./Lbs)	L (cm.)	W (cm.)
6/13	200	100

- Color: white

AFBXDSH3.0 Affiliate Box White Dash - 3 x 1.2 m. (L. x H.)

WEIGHT (Kg./Lbs)	L (cm.)	W (cm.)
8/17	300	120

- Color: white



AFBXDSHSTK04 "WOD" Sticker for White Board

AFBXDSHSTK01 Printed Custom Logo for White Dash

- Material: PVC - Color: white

YOUR LOGO



STORAGE

RKMAT03 Training Mats Adjustable Wall-Mounting Rack

WEIGHT (Kg./Lbs)	L (cm.)	W (cm.)	H (cm.)
1.5 / 3.3	65	7.6	24

- Material: Powder coated steel - Color: Grey
- Min./Max. loadable mats: 1 to 30 (4 mm. thickness) - Max. load: 50 kg.
- Steel plate thickness: 1.5 mm. - Min./max. Hook wheel-track: from 37 cm. to 52 cm.



RKMAT05 Training Mats Wall-Mounting Rack

WEIGHT (Kg./Lbs)	L (cm.)	W (cm.)	H (cm.)
6 / 13	65	7	21.5

- Material: Powder coated steel - Color: Matte black
- Min. / Max. loadable mats: 1 to 30 (4 mm. thickness)
- Max. load: 50 kg. - Steel plate thickness: 5 mm.



RKMSVST01 Massive Storage Rack - Multistorage Unit for: Dumbbells-Bumpers-Kettlebells-Wall Balls-Fractional Plates-Loop Bands

- Massive Storage Rack - Side Upright w/wheels - x2PCs
- Massive Storage Rack - Dumbbells Tier - x1PC
- Massive Storage Rack - Kettlebells Tier - x1PC
- Massive Storage Rack - Bumpers and WallBalls Tier - x1PC
- Storage Rack Option - Side Fractional Plates Sleeve - x3PCs
- Storage Rack Option - Side Loop Bands Hook - x1PC
- Storage Rack Option - Bumper Tier Splitter - x1PC

WEIGHT (Kg./Lbs)	L (cm.)	W (cm.)	H (cm.)
60 / 132	201	50	123

- Material: Powder coated steel - Color: Matte black



RKMSVST02 Double Massive Storage Rack - Multistorage Unit for: Dumbbells-Bumpers-Kettlebells-Wall Balls-Fractional Plates-Loop Bands

- Massive Storage Rack - Side Upright w/wheels - x3PCs
- Massive Storage Rack - Dumbbells Tier - x2PCs
- Massive Storage Rack - Kettlebells Tier - x2PCs
- Massive Storage Rack - Bumpers and WallBalls Tier - x2PCs
- Storage Rack Option - Side Fractional Plates Sleeve - x3PCs
- Storage Rack Option - Side Loop Bands Hook - x1PC
- Storage Rack Option - Bumper Tier Splitter - x2PCs

WEIGHT (Kg./Lbs)	L (cm.)	W (cm.)	H (cm.)
110 / 242.5	356	50	123

- Material: Powder coated steel - Color: Matte black



STORAGE

RKMSVST03 Massive Storage Rack - Multistorage Unit for: Dumbbells-Fractional Plates-Loop Bands

- Massive Storage Rack - Side Upright w/wheels - x2PCs
- Massive Storage Rack - Dumbbells Tier - x3PCs
- Storage Rack Option - Side Fractional Plates Sleeve - x3PCs
- Storage Rack Option - Side Loop Bands Hook - x1PC

WEIGHT (Kg./Lbs)	L (cm.)	W (cm.)	H (cm.)
55 / 121	201	50	123

- Material: Powder coated steel - Color: Matte black



RKMSVST04 Massive Storage Rack - Multistorage Unit for: Kettlebells-Fractional Plates-Loop Bands

- Massive Storage Rack - Side Upright w/wheels - x2PCs
- Massive Storage Rack - Kettlebells Tier - x3PCs
- Storage Rack Option - Side Fractional Plates Sleeve - x3PCs
- Storage Rack Option - Side Loop Bands Hook - x1PC

WEIGHT (Kg./Lbs)	L (cm.)	W (cm.)	H (cm.)
75 / 165	201	50	123

- Material: Powder coated steel - Color: Matte black



RKMSVST05 Massive Storage Rack - Multistorage Unit for: Wallballs-Fractional Plates-Loop Bands

- Massive Storage Rack - Side Upright w/wheels - x2PCs
- Massive Storage Rack - WallBalls Tier - x2PCs
- Massive Storage Rack - Bumpers and WallBalls Tier - x1PC
- Storage Rack Option - Side Fractional Plates Sleeve - x3PCs
- Storage Rack Option - Side Loop Bands Hook - x1PC

WEIGHT (Kg./Lbs)	L (cm.)	W (cm.)	H (cm.)
50 / 110	201	50	123

- Material: Powder coated steel - Color: Matte black



STORAGE

RKMSVSTX01 Massive Storage Rack - Dumbbells Tier

WEIGHT (Kg./Lbs)	L (cm.)	W (cm.)	H (cm.)
14 / 31	152.5	26	14

- Material: Powder coated steel - Color: Matte black

RKMSVSTX02 Massive Storage Rack - Kettlebells Tier

WEIGHT (Kg./Lbs)	L (cm.)	W (cm.)	H (cm.)
27 / 60	152.5	40	21

- Material: Powder coated steel - Color: Matte black

RKMSVSTX03 Massive Storage Rack - WallBalls Tier

WEIGHT (Kg./Lbs)	L (cm.)	W (cm.)	H (cm.)
11 / 24	152.5	26	16

- Material: Powder coated steel - Color: Matte black

RKMSVSTX04 Massive Storage Rack - Bumpers and WallBalls Tier

WEIGHT (Kg./Lbs)	L (cm.)	W (cm.)	H (cm.)
10 / 22	150	22	5

- Material: Powder coated steel - Color: Matte black

RKMSVSTX05 Massive Storage Rack - Side Upright w/wheels

WEIGHT (Kg./Lbs)	L (cm.)	W (cm.)	H (cm.)
12 / 26.5	104	50	7.5

- Material: Powder coated steel - Color: Matte black

RKMSVSTX06 Storage Rack Option - Side Fractional Plates Sleeve

WEIGHT (Kg./Lbs)	L (cm.)	W (cm.)	H (cm.)
2 / 4.4	21	20	7

- Material: Powder coated steel - Color: Matte black

RKMSVSTX07 Storage Rack Option - Side Loop Bands Hook

WEIGHT (Kg./Lbs)	L (cm.)	W (cm.)	H (cm.)
2 / 4.4	20	7	15

- Material: Powder coated steel - Color: Matte black

RKMSVSTX08 Storage Rack Option - Bumper Tier Splitter

WEIGHT (Kg./Lbs)	L (cm.)	W (cm.)	H (cm.)
1.3 / 2.8	28	5	30

- Material: Powder coated steel - Color: Matte black





THE BARBELL CLUB
USA[®]

3
4
5
6
7

5
6
7

1
2
3
4
5
6

1
2
3
4
5
6

11
22
33

6
5

WE REALLY CONCERN ABOUT SAFETY

The XRIG™ series was born to provide a never-ending range of items thought to build-up any kind of Crossfit® station. Besides all the pre-set configurations drawn by our R&D Dept., customers could be able to choose among dozens of parts and options so to really have their own station. When a customer gets in touch with our sales team and he needs to be assisted with the drawing of his own station, our XRIG™ team of product's designers draw the station according to customer's needs and provide to him the final 3D drawing with all the main specs and sizes. This process helps the customers to have either a bespoke product and a safe station, cause any customer's sketch, is first switched in to a 3D drawing and then checked by the product designers also for what concern the safety and the stability of all the parts once bolted together.

Thanks to our in-house tech department, all needs can be matched: custom sizes, custom colors etc..



TUV-SUD: most of our products (such as benches, racks, Crossfit® stations etc..) are tested and certified by the TUV-SUD®, that is one of the worldwide most affordable product testing company. All products are tested in order to comply with the latest products safety regulations (E.G: in Europe the EN-ISO 20957-1, EN-ISO 957-2 and EN-ISO 957-4)*. All along the catalogue we have mentioned which products are tested according to TUV-SUD® safety specs.

We furthermore care about the safety of the electronic products we carry. Either for the Xenios USA® items and for any third-brand product, we make sure they feature all needed certification, such as, for example, the CE and the ROHS ones*

In order to make really reliable products, we also concern about safety and quality certifications of raw materials (such as, for example, the steel tubes used to make the whole XRIG™ range of items), painting and coating materials and processes, hardware, welding process and welder's certified skills. A product making process involve dozens of matters, from raw materials selection up to the packaging of the finished goods, and our R&D and Product Team is just formed by experienced technicians and engineers that can let us be proud to label a workout tool with our logo.

**Some of the mentioned products' safety regulations and/or safety marks may not be valid for some Countries.*

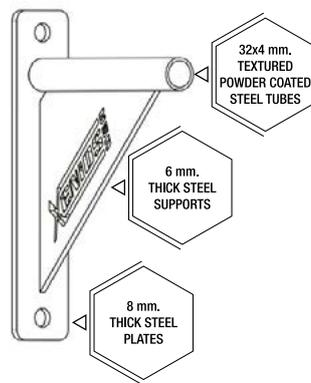
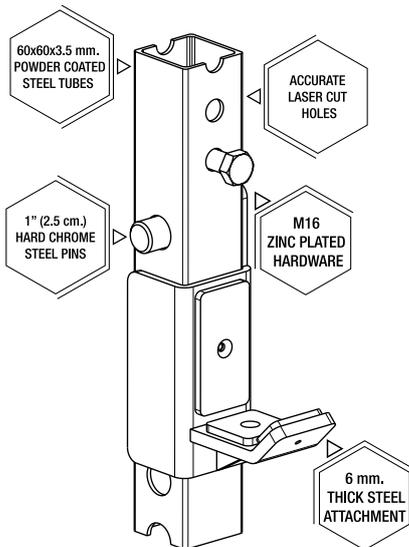

STEEL TUBES All XRIG™ parts are made by using stiff steel tubes so to really be ready to bear severe workouts made by several athletes at a time. The steel used to make the tubes is just the S235J steel (UNI-EN 10219-2 compliance*) , one of the strongest on the market. All square tubes are 6x6 cm. sized and 3.5 mm. thickness (11+ gauges), while all the round tubes are 32 mm. diameter by 4 mm. thickness. All main steel parts are bolted together just by using M16 bolts, coupled with M16 self-locking nuts: up to 300 Nm in tightening strength. All bolts feature safety pvc end-caps so to avoid any chance of injury with the offset of the same bolts out of the nuts after being tightened. All hardware is zinc plated so to be rust-proof.



WELDING All steel parts are welded just by robot and robots are managed just by skilled certified workers, so to have a consistent welding line all-around the tubes' junctions. Moreover, all holes for bolts and for snap-in / snap-off options are drilled by laser so to be really accurate in diameter and position.



COATING The standard color of the whole XRIG™ range is the special Xenios USA® XRIG™ Black powder coating. After several tests on the mix of the powder and the coating/drying process, we have found the way to have an high-bonding ratio kind of coating that features a special texture on its surface (once dried), so to provide the right grip for harmless and firmly Muscle-Ups. The special Xenios USA® powder coating is furthermore made by adding to the formula a slightly percentage of wax that makes the coating almost scratch-proof. All steel parts are not less than 60 micron coated.

Wherever there are bare steel components (such as pins, poles, or junctions), we protect them just by using the industrial galvanizing process called Hard Chrome.

CrossFit® is a registered trademark of Crossfit Inc.(USA). The Xenios USA company and registered trademarks are not affiliated and/or associated with and/or endorsed and/or sponsored by Crossfit Inc. The Xenios USA products and services are not endorsed, tested, sponsored by and/or associated with Crossfit Inc. and/or with any of the registered trademarks, products and services of Crossfit Inc.



The XRIG™ series can be also manufactured following the really heavy duty features of the MAGNUM™ range of products. Thought for those who really need to face severe workout, the MAGNUM™ series is a kind of tank-like range of products that can be never-ending overloaded.

At Xenios USA® we have thought to the best way to let some products be also manufactured following a kind of next-level bill of specifications. There are some workout tools, such as the Squat Stand, or the Yoke and Sled, or the Utility Flat Bench, or many parts and pre-set configurations of the XRIG™ series, that may be employed to bear tough workouts or quite heavy body-weights, such as the ones of the Strongmen. Due to those reasons, all mentioned items have been also drawn bigger and stronger: they have been drawn in order to comply with the serious overloading tests performed on to all the products that aim to belong to the MAGNUM™ series. All products made to belong to the MAGNUM™ series are made with an industrial grade of steel tubes. All square

steel tubes are bigger in size - switched from the standard 6x6 cm. to the oversized 8x8 cm. - and in thickness – switched from the standard 10 Gauge (3 mm.) or 11 Gauge (3.5 mm) to the oversized 8 Gauge (4.2 mm.).

All MAGNUM™ series products are welded by using a special certified kind of welding-robots, commonly involved with the construction of industrial machines like big cranes.

All Steel plates and sheets used to manufacture the MAGNUM™ products are thicker than the standard ones. Furthermore, the MAGNUM™ products are tested in order to bear heavier weights: three times higher than their “younger” brothers. E.G.: a Magnum Squat Stand is tested to bear up to 1500 Kg. so we can say it is almost unbreakable.

Xenios USA®

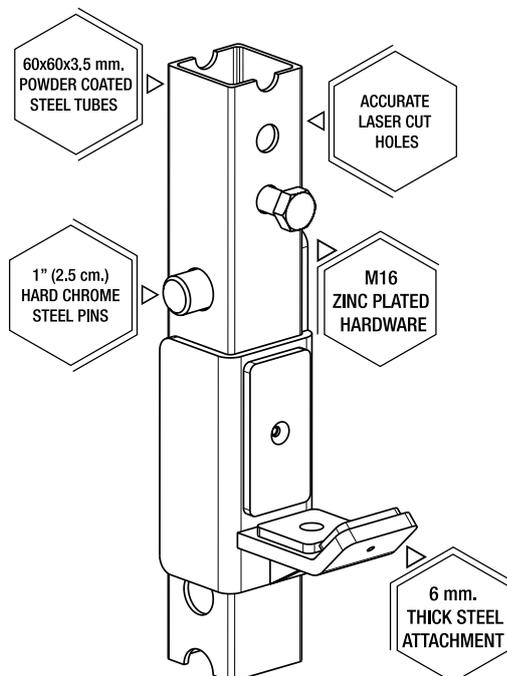

Xenios USA®

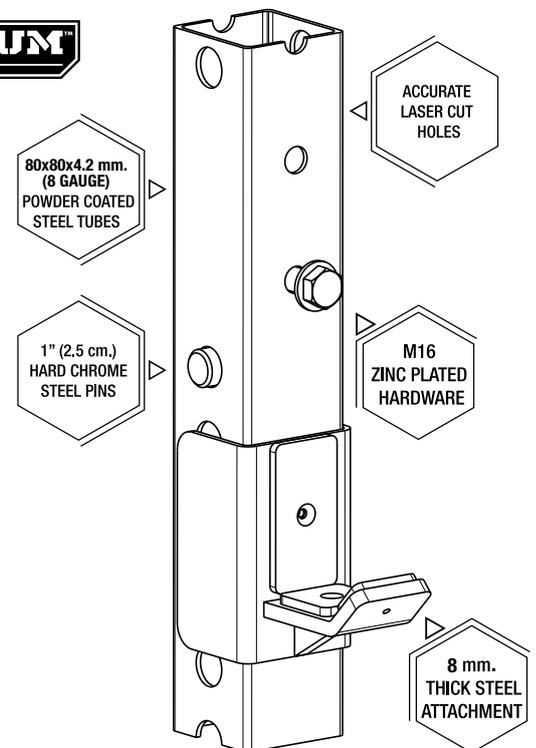

All MAGNUM™ products parts are made by using industrial grade steel tubes so to really be ready to bear “oversized” workouts. The steel used to make the MAGNUM tubes is normally employed in industrial machine constructions, such as the building cranes. All square tubes are 8x8 cm. sized and 4.2 mm. thickness (8 Gauges), while all the round tubes are 32 mm. diameter by 4 mm. thickness. All steel plates and brackets are made using no-lower than 8 mm. thickness steel sheets. All main steel parts are bolted together just by using M16 bolts, coupled with M16 self-locking nuts: up to 300 Nm in tightening strength. All bolts feature safety pvc end-caps so to avoid any chance of injury with the offset of the same bolts out of the nuts after being tightened. All hardware is zinc plated so to be rust-proof.

AVAILABLE ON DEMAND

OUTDOOR PROOF

Once we have started to develop our XRIG™ range of products, our R&D team has also thought to those who need to set a station up, out of the door of their Box and, even worse, without sheltering it. So, that is one of the reason cause we are one of the few makers on the market to be able to provide all the XRIG™ parts made with a special treatment for elements protection. When an XRIG™ station is made to be outdoor installed, all steel components are first zinc-plated (our zinc-plating process are all certified in accordance with the UNI-EN ISO 1461:2009 regulation*) and then powder coated with an upgraded kind of powder coating. This special process, along with special water-draining holes drilled on to the main Uprights of the station, makes it totally rust-proof and so ready to bear the elements' power. **



CUSTOM COLORS Even though the standard color of the XRIG™ parts is the above mentioned Xenios USA® XRIG™ Black one, customers can have the chance to choose their own color for the whole station or even for some of the parts it is made of (such as, for example, the uprights). All available colors feature the same specs of the standard XRIG™ Black of Xenios USA®, especially for what concern the unique light-textured surface that gives to the pull-up bars the perfect grip for the muscle-ups. **

TEXTURED SURFACE COLORS



CUSTOM SIZE

Since we are the original maker of the XRIG™ range and since we think customers' needs can't really be all foreseen in advance, an XRIG™ station can be also drawn with totally bespoke parts. Should you need, for example, taller uprights or shorter pull-up bars, or anything "crazy" you may have invented, at Xenios USA® we will match your requirements by even drawing from the scratches your unique parts. **

XRIG™ WARRANTY



All XRIG™ steel parts in case of steel breakages and/or welding breakages.



All Outdoor Proof XRIG™ steel parts in case of rust-spots arising from coating and in case of steel corrosion-perforation.



All XRIG™ steel parts in case of rust-spots arising from coating. All XRIG™ Hardware and other components.

Warranty will void in case of outdoor use, unless the XRIG™ items were made with the special Xenios USA® "Outdoor Proof Treatment". Warranty against rust never covers rust rising on scratched and/or worn-by-the-use and/or speal-made parts steel areas. Bear steel due to scratches and/or dents can get rust unless not coated and/or retouched again. For any further about Xenios USA® products' warranty, please refer to the Xenios USA® Warranty Chart, available at www.xeniosusa.com

***Attention: CUSTOM COLOR, CUSTOM SIZES and OUTDOOR PROOF are priced options. Ask to the Xenios USA® Team to learn more about them.*



XRIG™ STATIONS

RKXFIT01* XRIG™ - RIG 6'x 6' x 9' - w/English Ladder

- XRIG™ - 9' Basic Upright (270 cm.)x4PCs
- XRIG™ - 6' English Ladder Bar (168 cm.)x2PCs
- XRIG™ - 6' English Ladder Side-Bar (168 cm.)x2PCs
- XRIG™ - 6' Basic Pull-Up frame (168 cm.)x2PCs

WEIGHT (Kg./Lbs)	L (cm.)	W (cm.)	H (cm.)
147 / 324	180	180	270

- Material: Powder coated steel - Color: Matte black
 - Steel tubes size: 60x60x3.5 mm. + 32x4 mm. round tubes.

* Above configuration is also available w/o English Ladder on top.

- *1 English ladder bars can be also side-bolted to form a vertical plyo-ladder
- *2 - Pull-Up heights: 6'10"-7'6"-8'3" (only w/12' Uprights)
- Can be switched with: Double Cross Member (VSXFIT22/23)/Muscle-Up (VSXFIT28/21/36/37) /Offset Pull-Up Frame (VSXFIT01/06)/Offset Pull-Up Bar (VSXFIT35/36)
- Pull-Up heights: 8'74"-6'10"

*3 The English Ladder Side Bar can be bolted at 8.74' (265 cm.) or 6'10" (207 cm.) off the ground.

XRIG™ configurations come disassembled.

ALL XRIG™ PRE-SET CONFIGS CAN BE FULLY CUSTOMIZED OR UPGRADED UP TO CUSTOMER'S REQUIREMENTS.

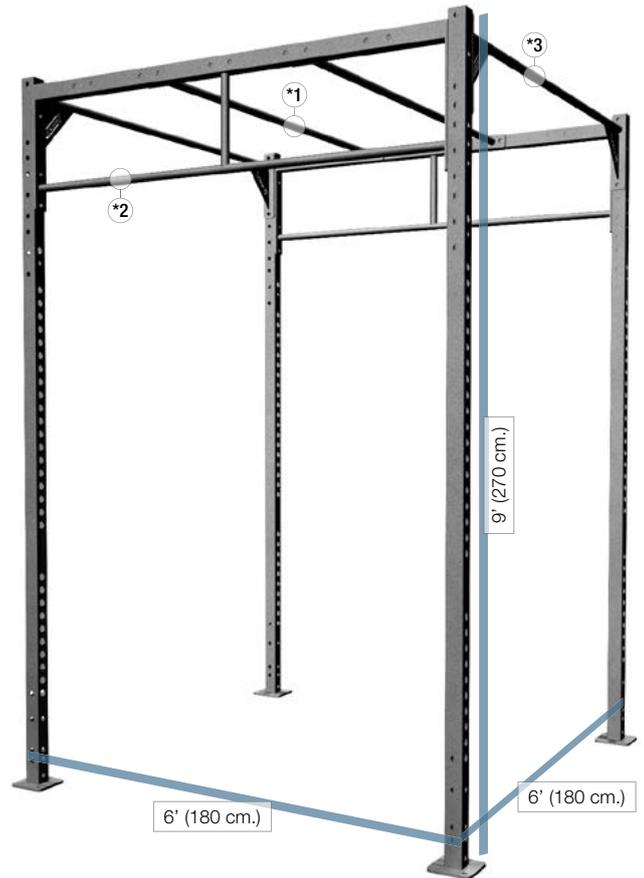

XRIG™ STATIONS

RKXFIT02* XRIG™ - RACK 4'x 6' x 9' - w/English Ladder - w/Bar J-Rack

- XRIG™ - 9' Basic Upright (270 cm.)x4PCs
- XRIG™ - 6' English Ladder Bar (168 cm.)x1PC
- XRIG™ - 6' English Ladder Side-Bar (168 cm.)x2PCs
- XRIG™ - 4' Basic Pull-Up frame (108 cm.)x2PCs
- XRIG™ - Bar J-Rack - x4PCs

WEIGHT (Kg./Lbs)	L (cm.)	W (cm.)	H (cm.)
140 / 308.5	120	180	270

- Material: Powder coated steel - Color: Matte black
 - Steel tubes size: 60x60x3.5 mm. + 32x4 mm. round tubes.

* Above configuration is also available w/o English Ladder on top.

- *1 English Ladder Bars can be also side-bolted to form a vertical plyo-ladder
- *2 - Pull-Up heights: 6'10"-7'6"-8'3" (only w/12' Uprights)
- Can be switched with: Double Cross Member (VSXFIT22/23)/Muscle-Up (VSXFIT28/21/36/37) /Offset Pull-Up Frame (VSXFIT01/06)/Offset Pull-Up Bar (VSXFIT35/36)
- Pull-Up heights: 8'74"-6'10"

*3 The English Ladder Side Bar can be bolted at 8.74' (265 cm.) or 6'10" (207 cm.) off the ground.

XRIG™ configurations come disassembled.

ALL XRIG™ PRE-SET CONFIGS CAN BE FULLY CUSTOMIZED OR UPGRADED UP TO CUSTOMER'S REQUIREMENTS.

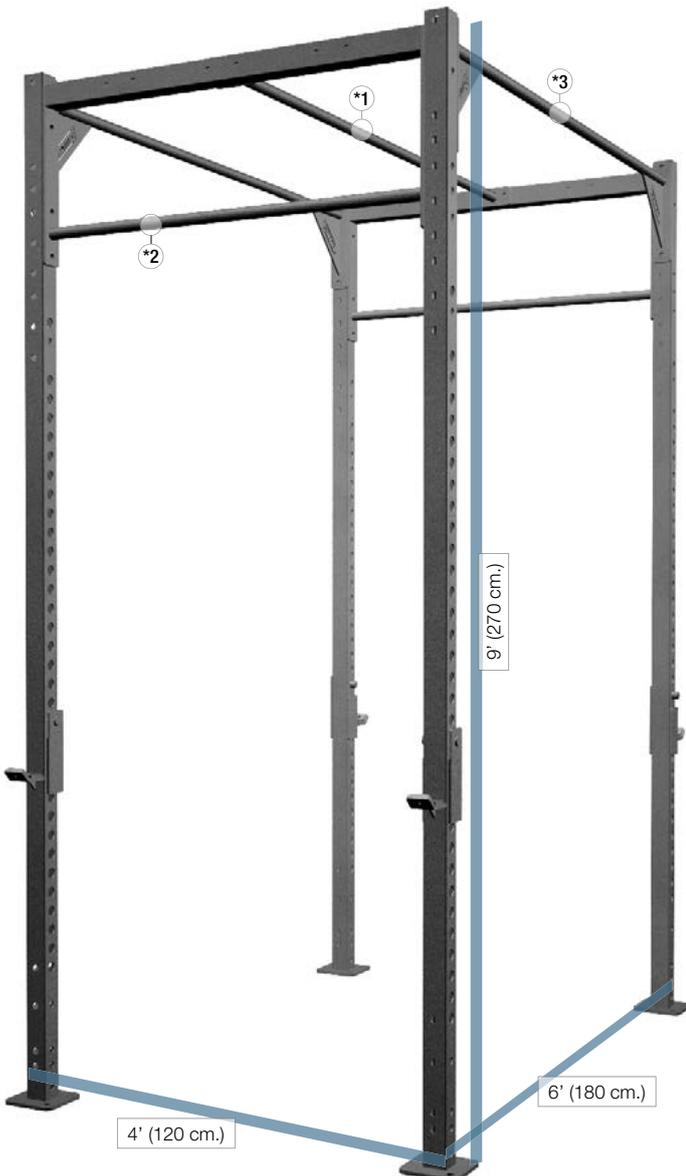

XRIG™ STATIONS

RKXFIT03* XRIG™ - RIG 6'x 6' x 9' - Wall mounted - w/English Ladder™

- XRIG™ - 9' Basic Upright (270 cm.)x2PCs
- XRIG™ - 6' English Ladder Bar (168 cm.)x2PCs
- XRIG™ - 6' English Ladder Side-Bar (168 cm.)x2PCs
- XRIG™ - 6' Basic Pull-Up frame (168 cm.)x1PC

WEIGHT (Kg./Lbs)	L (cm.)	W (cm.)	H (cm.)			
88 / 194	180	180	270	x 6	x 2	x 2

- Material: Powder coated steel - Color: Matte black
- Steel tubes size: 60x60x3.5 mm. + 32x4 mm. round tubes.

* Above configuration is also available w/o English Ladder on top.

- *1 English Ladder Bars can be also side-bolted to form a vertical plyo-ladder
- *2 - Pull-Up heights: 6'10"-7'6"-8'3" (only w/12' Uprights)
- Can be switched with: Double Cross Member (VSXFIT22/23)/Muscle-Up (VSXFIT28/21/36/37) /Offset Pull-Up Frame (VSAXFIT01/06)/Offset Pull-Up Bar (VSAXFIT35/36)
- Pull-Up heights: 8'74"-6'10"
- *3 The English Ladder Side Bar can be bolted at 8.74' (265 cm.) or 6'10" (207 cm.) off the ground.

XRIG™ configurations come disassembled.

ALL XRIG™ PRE-SET CONFIGS CAN BE FULLY CUSTOMIZED OR UPGRADED UP TO CUSTOMER'S REQUIREMENTS.

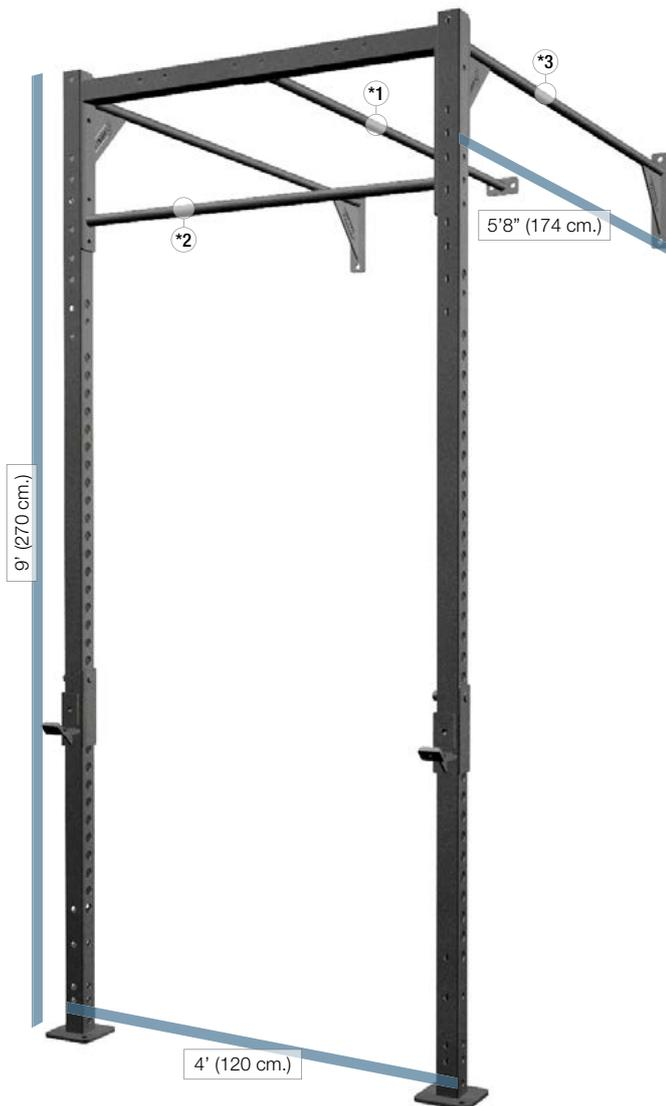
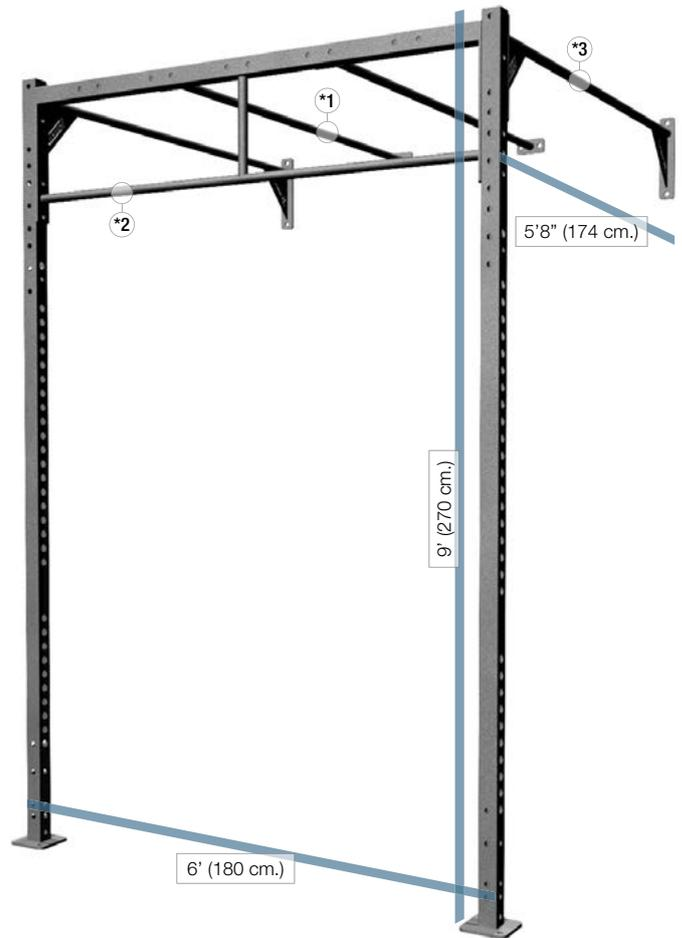

XRIG™ STATIONS

RKXFIT04* XRIG™ - RACK 4'x 6' x 9' - Wall mounted - w/English Ladder - w/Bar J-Rack

- XRIG™ - 9' Basic Upright (270 cm.)x2PCs
- XRIG™ - 6' English Ladder Bar (168 cm.)x1PC
- XRIG™ - 6' English Ladder Side-Bar (168 cm.)x2PCs
- XRIG™ - 4' Basic Pull-Up frame (108 cm.)x1PC
- XRIG™ - Bar J-Rack - x2PCs

WEIGHT (Kg./Lbs)	L (cm.)	W (cm.)	H (cm.)			
82 / 180	120	180	270	x 6	x 2	x 2

- Material: Powder coated steel - Color: Matte black
- Steel tubes size: 60x60x3.5 mm. + 32x4 mm. round tubes.

* Above configuration is also available w/o English Ladder on top.

- *1 English Ladder Bars can be also side-bolted to form a vertical plyo-ladder
- *2 - Pull-Up heights: 6'10"-7'6"-8'3" (only w/12' Uprights)
- Can be switched with: Double Cross Member (VSXFIT22/23)/Muscle-Up (VSXFIT28/21/36/37) /Offset Pull-Up Frame (VSAXFIT01/06)/Offset Pull-Up Bar (VSAXFIT35/36)
- Pull-Up heights: 8'74"-6'10"
- *3 The English Ladder Side Bar can be bolted at 8.74' (265 cm.) or 6'10" (207 cm.) off the ground.

XRIG™ configurations come disassembled.

ALL XRIG™ PRE-SET CONFIGS CAN BE FULLY CUSTOMIZED OR UPGRADED UP TO CUSTOMER'S REQUIREMENTS.



XRIG™ STATIONS

XRIG™ STATIONS

RKXFIT05* XRIG™ - RIG + RACK 10'x 6' x 9' - w/English Ladder - w/Bar J-Rack

- XRIG™ - 9' Basic Upright (270 cm.)x6PCs
- XRIG™ - 6' English Ladder Bar (168 cm.)x3PCs
- XRIG™ - 6' English Ladder Side-Bar (168 cm.)x3PCs
- XRIG™ - 6' Basic Pull-Up frame (168 cm.)x2PCs
- XRIG™ - 4' Basic Pull-Up frame (108 cm.)x2PCs
- XRIG™ - Bar J-Rack - x4PCs

WEIGHT (Kg./Lbs)	L (cm.)	W (cm.)	H (cm.)
238 / 525	300	180	270

- Material: Powder coated steel - Color: Matte black
 - Steel tubes size: 60x60x3.5 mm. + 32x4 mm. round tubes.

* Above configuration is also available w/o English Ladder on top.

- *1 English Ladder Bars can be also side-bolted to form a vertical plyo-ladder
- *2 - Pull-Up heights: 6'10"-7'6"-8'3" (only w/12' Uprights)
- Can be switched with: Double Cross Member (VSXFIT22/23)/Muscle-Up (VSXFIT28/21/36/37) /Offset Pull-Up Frame (VSAXFIT01/06)/Offset Pull-Up Bar (VSAXFIT35/36)
- Pull-Up heights: 8'74"-6'10"
- *3 The English Ladder Side Bar can be bolted at 8.74' (265 cm.) or 6'10" (207 cm.) off the ground.

XRIG™ configurations come disassembled.

ALL XRIG™ PRE-SET CONFIGS CAN BE FULLY CUSTOMIZED OR UPGRADED UP TO CUSTOMER'S REQUIREMENTS.



XRIG™ STATIONS

RKXFIT06* XRIG™ - RIG + RACK 10'x 6' x 9' - Wall mounted - w/English Ladder - w/Bar J-Rack

- XRIG™ - 9' Basic Upright (270 cm.)x3PCs
- XRIG™ - 6' English Ladder Bar (168 cm.)x3PCs
- XRIG™ - 6' English Ladder Side-Bar (168 cm.)x3PCs
- XRIG™ - 6' Basic Pull-Up frame (168 cm.)x1PC
- XRIG™ - 4' Basic Pull-Up frame (108 cm.)x1PC
- XRIG™ - Bar J-Rack - x2PCs

WEIGHT (Kg./Lbs)	L (cm.)	W (cm.)	H (cm.)
140.5 / 310	300	180	270

- Material: Powder coated steel - Color: Matte black
 - Steel tubes size: 60x60x3.5 mm. + 32x4 mm. round tubes.

* Above configuration is also available w/o English Ladder on top.

- *1 English Ladder Bars can be also side-bolted to form a vertical plyo-ladder
- *2 - Pull-Up heights: 6'10"-7'6"-8'3" (only w/12' Uprights)
- Can be switched with: Double Cross Member (VSXFIT22/23)/Muscle-Up (VSXFIT28/21/36/37) /Offset Pull-Up Frame (VSAXFIT01/06)/Offset Pull-Up Bar (VSAXFIT35/36)
- Pull-Up heights: 8'74"-6'10"
- *3 The English Ladder Side Bar can be bolted at 8.74' (265 cm.) or 6'10" (207 cm.) off the ground.

XRIG™ configurations come disassembled.

ALL XRIG™ PRE-SET CONFIGS CAN BE FULLY CUSTOMIZED OR UPGRADED UP TO CUSTOMER'S REQUIREMENTS.

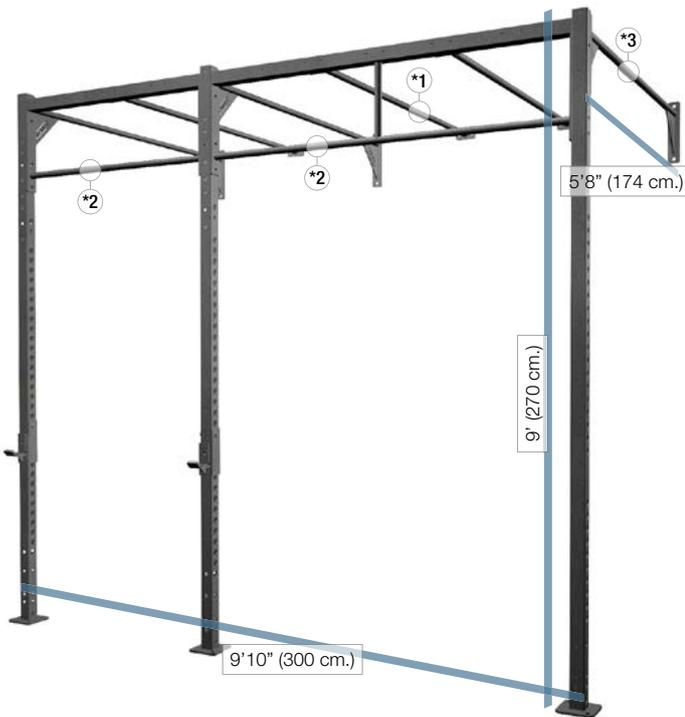

XRIG™ STATIONS

RKXFIT07* XRIG™ - Compact RIG 6' x 4' x 9' - Wall mounted

- XRIG™ - 9' Basic Upright (270 cm.)x2PCs
- XRIG™ - 4' Compact Pull-Up Bar (114 cm.)x2PCs
- XRIG™ - 6' Basic Pull-Up frame (168 cm.)x1PC

WEIGHT (Kg./Lbs)	L (cm.)	W (cm.)	H (cm.)
72 / 159	180	120	270



- Material: Powder coated steel - Color: Matte black
- Steel tubes size: 60x60x3.5 mm. + 32x4 mm. round tubes.

* Above configuration is also available w/o English Ladder on top.

- *² - Pull-Up heights: 6'10"-7'6"-8'3" (only w/12' Uprights)
- Can be switched with: Double Cross Member (VSFXFIT22/23)/Muscle-Up (VSFXFIT28/21/36/37) /Offset Pull-Up Frame (VSAXFIT01/06)/Offset Pull-Up Bar (VSAXFIT35/36)
- Pull-Up heights: 8'74"-6'10"

*³ The English Ladder Side Bar can be bolted at 8.74' (265 cm.) or 6'10" (207 cm.) off the ground.

XRIG™ configurations come disassembled.

ALL XRIG™ PRE-SET CONFIGS CAN BE FULLY CUSTOMIZED OR UPGRADED UP TO CUSTOMER'S REQUIREMENTS.

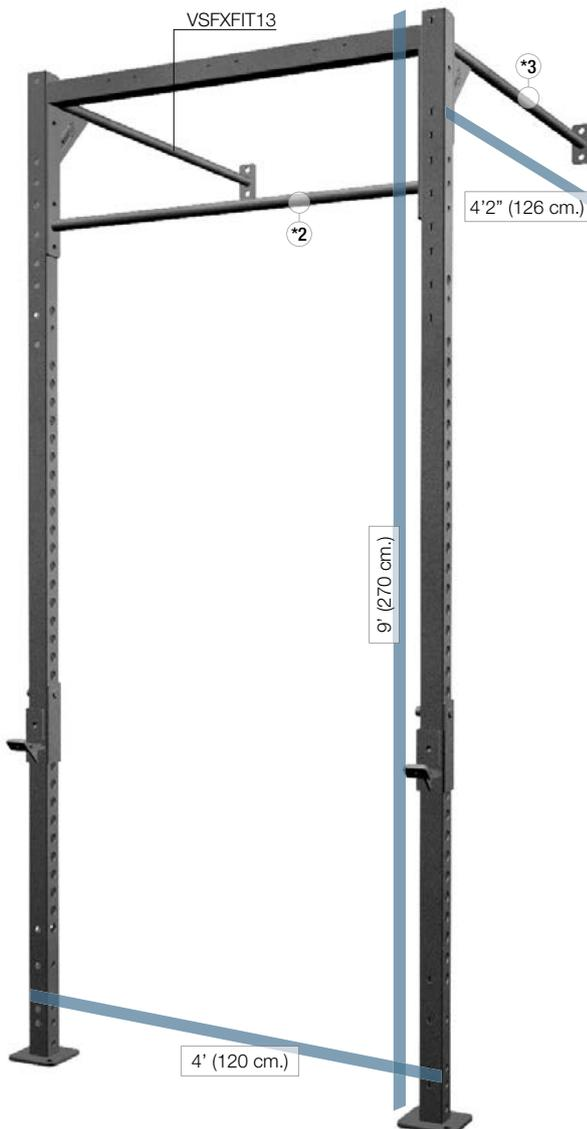
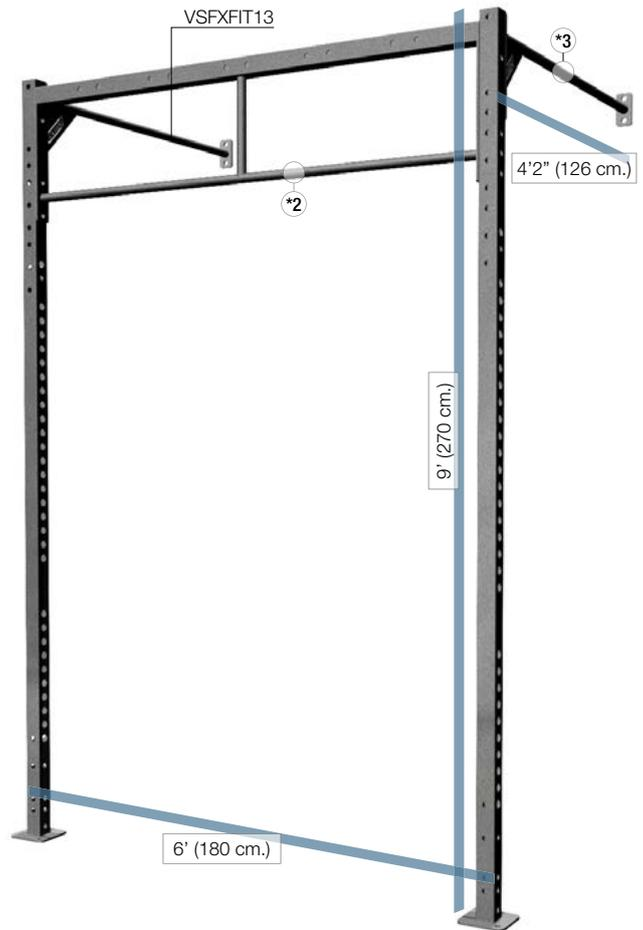

XRIG™ STATIONS

RKXFIT08* XRIG™ - Compact RACK 4' x 4' x 9' - Wall mounted - w/Bar J-Rack

- XRIG™ - 9' Basic Upright (270 cm.)x2PCs
- XRIG™ - 4' Compact Pull-Up Bar (114 cm.)x2PCs
- XRIG™ - 4' Basic Pull-Up frame (108 cm.)x1PC
- XRIG™ - Bar J-Rack - x2PCs

WEIGHT (Kg./Lbs)	L (cm.)	W (cm.)	H (cm.)
71 / 310	120	120	270



- Material: Powder coated steel - Color: Matte black
- Steel tubes size: 60x60x3.5 mm. + 32x4 mm. round tubes.

* Above configuration is also available w/o English Ladder on top.

- *¹ English Ladder Bars can be also side-bolted to form a vertical plyo-ladder
- *² - Pull-Up heights: 6'10"-7'6"-8'3" (only w/12' Uprights)
- Can be switched with: Double Cross Member (VSFXFIT22/23)/Muscle-Up (VSFXFIT28/21/36/37) /Offset Pull-Up Frame (VSAXFIT01/06)/Offset Pull-Up Bar (VSAXFIT35/36)
- Pull-Up heights: 8'74"-6'10"

*³ The English Ladder Side Bar can be bolted at 8.74' (265 cm.) or 6'10" (207 cm.) off the ground.

XRIG™ configurations come disassembled.

ALL XRIG™ PRE-SET CONFIGS CAN BE FULLY CUSTOMIZED OR UPGRADED UP TO CUSTOMER'S REQUIREMENTS.



XRIG™ STATIONS

XRIG™ STATIONS

RKXFIT09* XRIG™ - Compact RIG + RACK 10'x 4' x 9' - Wall mounted - w/Bar J-Rack

- XRIG™ - 9' Basic Upright (270 cm.)x3PCs
- XRIG™ - 4' Compact Pull-Up Bar (114 cm.)x3PCs
- XRIG™ - 6' Basic Pull-Up frame (168 cm.)x1PC
- XRIG™ - 4' Basic Pull-Up frame (108 cm.)x1PC
- XRIG™ - Bar J-Rack - x2PCs

WEIGHT (Kg./Lbs)	L (cm.)	W (cm.)	H (cm.)
117 / 258	300	120	270

- Material: Powder coated steel - Color: Matte black
 - Steel tubes size: 60x60x3.5 mm. + 32x4 mm. round tubes.

* Above configuration is also available w/o English Ladder on top.

*2 - Pull-Up heights: 6'10"-7'6"-8'3" (only w/12' Uprights)
 - Can be switched with: Double Cross Member (VSXFIT22/23)/Muscle-Up (VSXFIT28/21/36/37)
 /Offset Pull-Up Frame (VSAXFIT01/06)/Offset Pull-Up Bar (VSAXFIT35/36)
 - Pull-Up heights: 8'74"-6'10"
 *3 The English Ladder Side Bar can be bolted at 8.74' (265 cm.) or 6'10" (207 cm.) off the ground.

XRIG™ configurations come disassembled.

ALL XRIG™ PRE-SET CONFIGS CAN BE FULLY CUSTOMIZED OR UPGRADED UP TO CUSTOMER'S REQUIREMENTS.

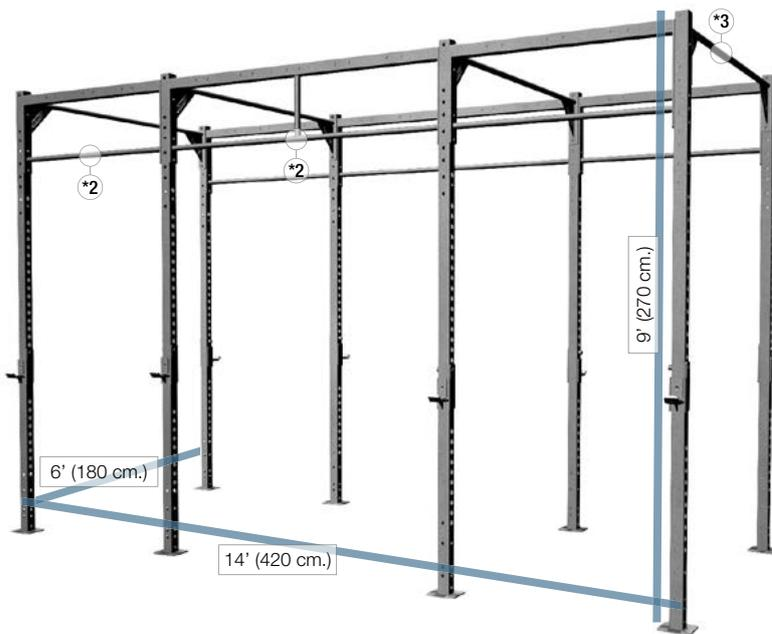
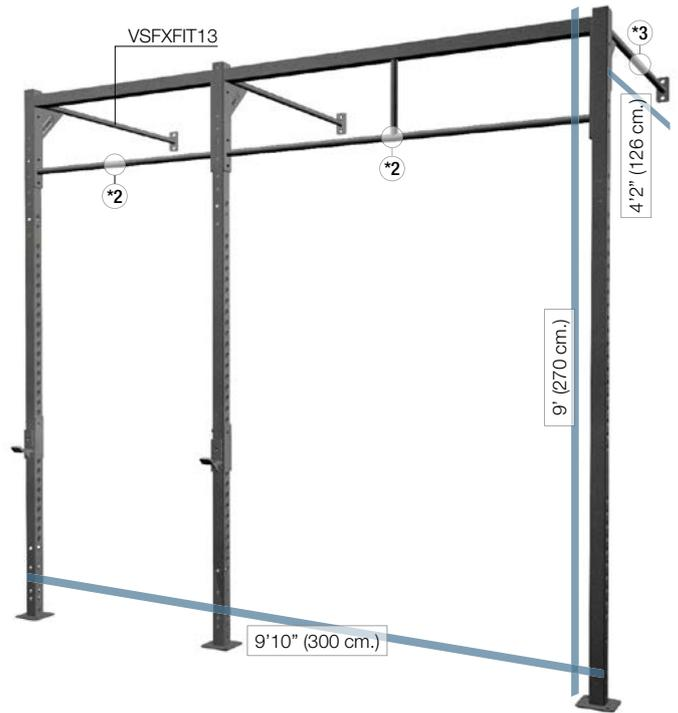

XRIG™ STATIONS

RKXFIT10[®] XRIG™ - War Path 3xRIG 26'x 6' x 9' - w/English Ladder

- XRIG™ - 9' Basic Upright (270 cm.)x8PCs
- XRIG™ - 12' Basic Upright (360 cm.)x4PCs
- XRIG™ - 6' Basic Pull-Up frame (168 cm.)x6PCs
- XRIG™ - 6' English Ladder Bar (168 cm.)x15PCs
- XRIG™ - 6' English Ladder Side-Bar (168 cm.)x6PCs
- XRIG™ - 6' Junction Bar (168 cm.)x2PCs
- XRIG™ - 6' Offset Wing Ladder (168 cm.)x2PCs
- XRIG™ - Wing Ladder reverse connection - x4PCs

WEIGHT (Kg./Lbs)	L (cm.)	W (cm.)	H (cm.)				
640 / 1411	780	180	360				

- Material: Powder coated steel - Color: Matte black
 - Steel tubes size: 60x60x3.5 mm. + 32x4 mm. round tubes.

* Above configuration is also available w/o English Ladder on top.

^{*1} English ladder bars can be also side-bolted to form a vertical plyo-ladder

^{*2} - Pull-Up heights: 6'10"-7'6"-8'3" (only w/12' Uprights)

- Can be switched with: Double Cross Member (VSXFIT22/23)/Muscle-Up (VSXFIT28/21/36/37)
 /Offset Pull-Up Frame (VSXFIT01/06)/Offset Pull-Up Bar (VSXFIT35/36)

- Pull-Up heights: 8'74"-6'10"

^{*3} The English Ladder Side Bar can be bolted at 8.74' (265 cm.) or 6'10" (207 cm.) off the ground.

XRIG™ configurations come disassembled.

ALL XRIG™ PRE-SET CONFIGS CAN BE FULLY CUSTOMIZED OR UPGRADED UP TO CUSTOMER'S REQUIREMENTS.

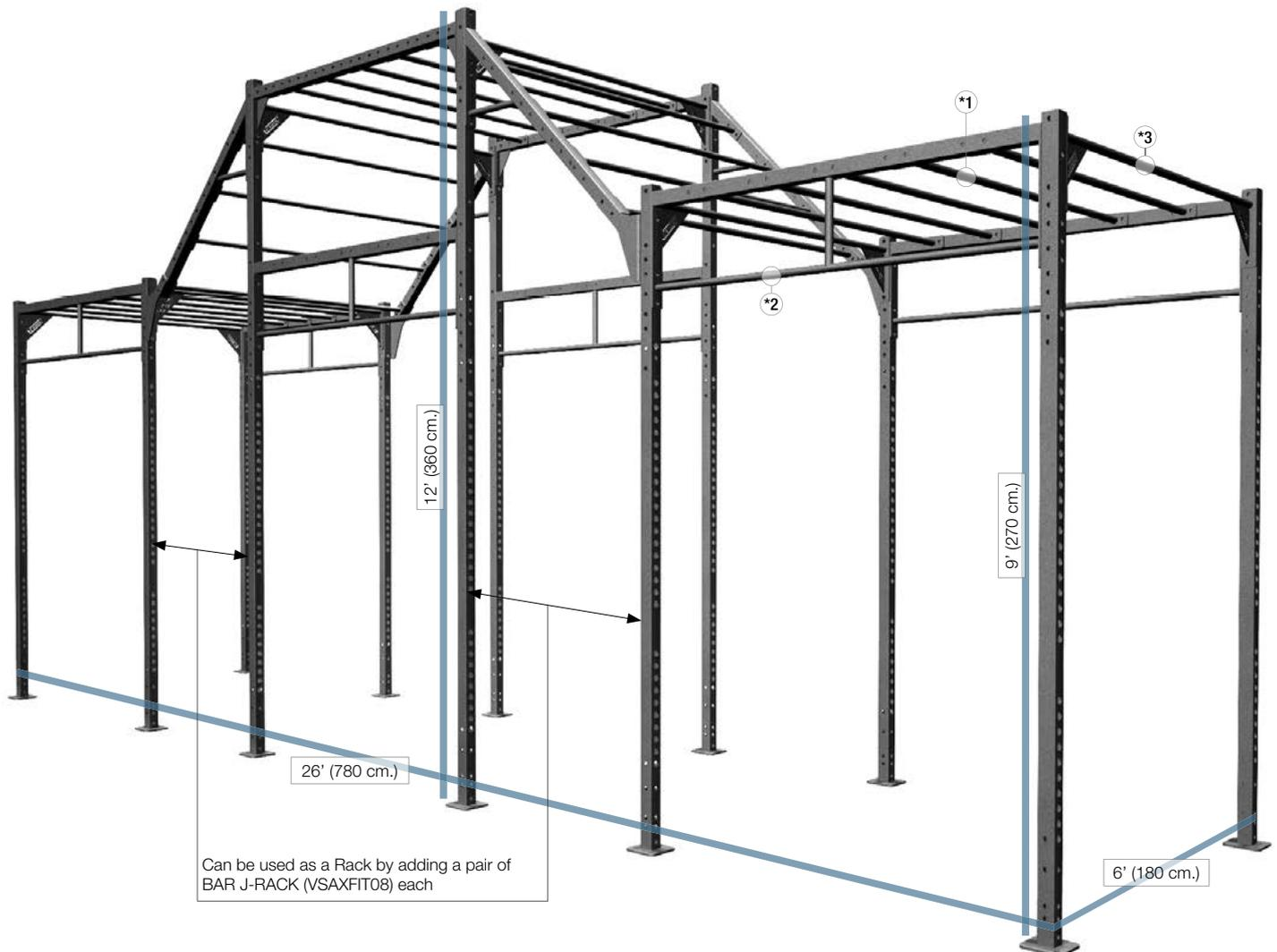

XRIG™ STATIONS

XRIG™ STATIONS

RKXFIT12™ XRIG™ - RIG + 2xRACK 14'x6'x9' - Wall mounted
- w/Bar J-Rack - w/o English Ladder

- XRIG™ - 9' Basic Upright (270 cm.)x4PCs
- XRIG™ - 6' English Ladder Side-Bar (180 cm.)x4PCs
- XRIG™ - Bar J-Rack - x4PCs
- XRIG™ - 6' Basic Pull-Up frame (168 cm.)x1PC
- XRIG™ - 4' Basic Pull-Up frame (108 cm.)x2PCs

WEIGHT (Kg./Lbs)	L (cm.)	W (cm.)	H (cm.)	 x12	 x4	 x4	 x1	 x2
173 / 381	420	180	270					

- Material: Powder coated steel - Color: Matte black
- Steel tubes size: 60x60x3.5 mm. + 32x4 mm. round tubes.

* Above configuration is also available w/o English Ladder on top.

*2 - Pull-Up heights: 6'10"-7'6"-8'3" (only w/12' Uprights)
- Can be switched with: Double Cross Member (VSXFIT22/23)/Muscle-Up (VSXFIT28/21/36/37)
/Offset Pull-Up Frame (VSAXFIT01/06)/Offset Pull-Up Bar (VSAXFIT35/36)
- Pull-Up heights: 8'74"-6'10"

*3 The English Ladder Side Bar can be bolted at 8.74' (265 cm.) or 6'10" (207 cm.) off the ground.

XRIG™ configurations come disassembled.

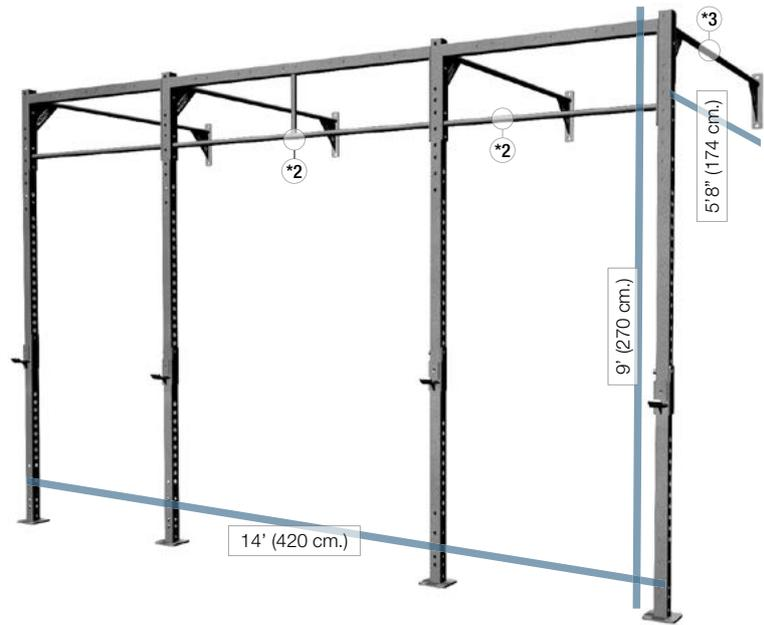

ALL XRIG™ PRE-SET CONFIGS CAN BE FULLY CUSTOMIZED OR UPGRADED UP TO CUSTOMER'S REQUIREMENTS.

XRIG™ STATIONS

RKXFIT13™ XRIG™ - 2xRIG + 2xRACK 20'x6'x9' - w/Bar J-Rack
- w/o English Ladder

- XRIG™ - 9' Basic Upright (270 cm.)x10PCs
- XRIG™ - 6' English Ladder Side-Bar (180 cm.)x5PCs
- XRIG™ - Bar J-Rack - x8PCs
- XRIG™ - 6' Basic Pull-Up frame (168 cm.)x4PCs
- XRIG™ - 4' Basic Pull-Up frame (108 cm.)x4PCs

WEIGHT (Kg./Lbs)	L (cm.)	W (cm.)	H (cm.)	 x22	 x5	 x4	 x4
396 / 873	600	180	270				

- Material: Powder coated steel - Color: Matte black
- Steel tubes size: 60x60x3.5 mm. + 32x4 mm. round tubes.

* Above configuration is also available w/o English Ladder on top.

*2 - Pull-Up heights: 6'10"-7'6"-8'3" (only w/12' Uprights)
- Can be switched with: Double Cross Member (VSXFIT22/23)/Muscle-Up (VSXFIT28/21/36/37)
/Offset Pull-Up Frame (VSAXFIT01/06)/Offset Pull-Up Bar (VSAXFIT35/36)
- Pull-Up heights: 8'74"-6'10"

*3 The English Ladder Side Bar can be bolted at 8.74' (265 cm.) or 6'10" (207 cm.) off the ground.

XRIG™ configurations come disassembled.

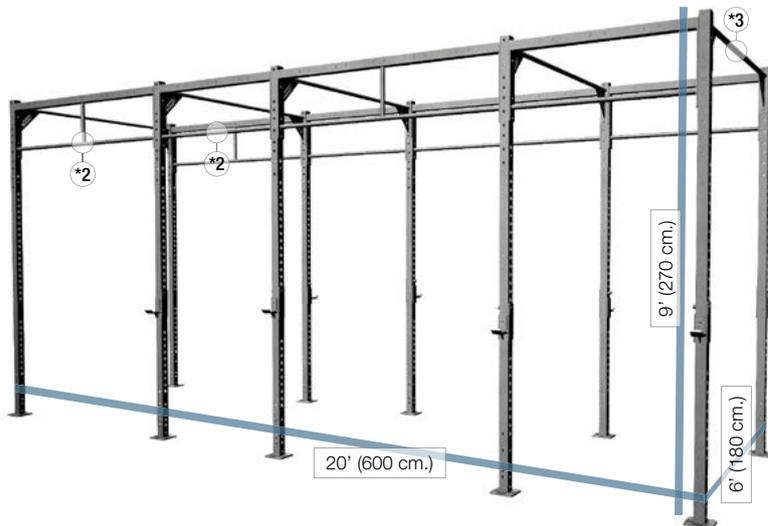

ALL XRIG™ PRE-SET CONFIGS CAN BE FULLY CUSTOMIZED OR UPGRADED UP TO CUSTOMER'S REQUIREMENTS.



XRIG™ STATIONS

RKXFIT14' XRIG™ - 2xRIG + 2xRACK 20'x6'x9' - Wall mounted
 - w/Bar J-Rack - w/o English Ladder

- XRIG™ - 9' Basic Upright (270 cm.)x5PCs
- XRIG™ - 6' English Ladder Side-Bar (180 cm.)x5PCs
- XRIG™ - Bar J-Rack - x4PCs
- XRIG™ - 6' Basic Pull-Up frame (168 cm.)x2PCs
- XRIG™ - 4' Basic Pull-Up frame (108 cm.)x2PCs

WEIGHT (Kg./Lbs)	L (cm.)	W (cm.)	H (cm.)				
221.5 / 488	600	180	270				

- Material: Powder coated steel - Color: Matte black
 - Steel tubes size: 60x60x3.5 mm. + 32x4 mm. round tubes.

* Above configuration is also available w/o English Ladder on top.

*2 - Pull-Up heights: 6'10"-7'6"-8'3" (only w/12' Uprights)
 - Can be switched with: Double Cross Member (VSXFIT22/23)/Muscle-Up (VSXFIT28/21/36/37)
 /Offset Pull-Up Frame (VSAXFIT01/06)/Offset Pull-Up Bar (VSAXFIT35/36)
 - Pull-Up heights: 8'74"-6'10"

*3 The English Ladder Side Bar can be bolted at 8.74' (265 cm.) or 6'10" (207 cm.) off the ground.

XRIG™ configurations come disassembled.

ALL XRIG™ PRE-SET CONFIGS CAN BE FULLY CUSTOMIZED OR UPGRADED UP TO CUSTOMER'S REQUIREMENTS.

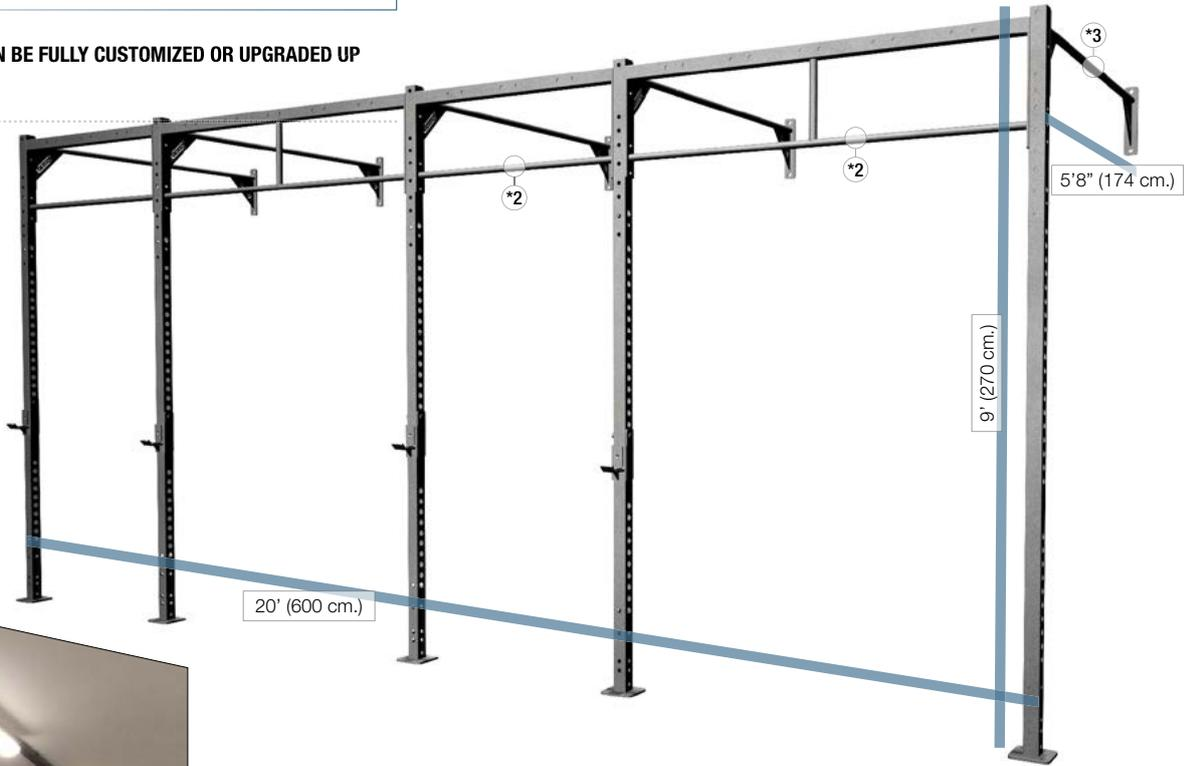

XRIG™ STATIONS

**RKXFIT15* XRIG™ - 2xRIG + 3xRACK 24'x6'x9' - w/Bar J-Rack
- w/o English Ladder**

- XRIG™ - 9' Basic Upright (270 cm.)x12PCs
- XRIG™ - 6' English Ladder Side-Bar (180 cm.)x6PCs
- XRIG™ - Bar J-Rack - x12PCs
- XRIG™ - 6' Basic Pull-Up frame (168 cm.) x4PCs
- XRIG™ - 4' Basic Pull-Up frame (108 cm.)x6PCs

WEIGHT (Kg./Lbs)	L (cm.)	W (cm.)	H (cm.)				
481 / 488	720	180	270				

- Material: Powder coated steel - Color: Matte black
- Steel tubes size: 60x60x3.5 mm. + 32x4 mm. round tubes.

* Above configuration is also available w/o English Ladder on top.

^{*2} - Pull-Up heights: 6'10"-7'6"-8'3" (only w/12' Uprights)
- Can be switched with: Double Cross Member (VSXFIT22/23)/Muscle-Up (VSXFIT28/21/36/37)
/Offset Pull-Up Frame (VSAXFIT01/06)/Offset Pull-Up Bar (VSAXFIT35/36)
- Pull-Up heights: 8'74"-6'10"

^{*3} The English Ladder Side Bar can be bolted at 8.74' (265 cm.) or 6'10" (207 cm.) off the ground.

XRIG™ configurations come disassembled.

ALL XRIG™ PRE-SET CONFIGS CAN BE FULLY CUSTOMIZED OR UPGRADED UP TO CUSTOMER'S REQUIREMENTS.



XRIG™ STATIONS

RKXFIT16^{*} XRIG™ - 2xRIG + 3xRACK 24'x6'x9' - Wall mounted
 - w/Bar J-Rack - w/o English Ladder

- XRIG™ - 9' Basic Upright (270 cm.)x6PCs
- XRIG™ - 6' English Ladder Side-Bar (180 cm.)x6PCs
- XRIG™ - Bar J-Rack - x6PCs
- XRIG™ - 6' Basic Pull-Up frame (168 cm.)x2PCs
- XRIG™ - 4' Basic Pull-Up frame (108 cm.)x3PCs

WEIGHT (Kg./Lbs)	L (cm.)	W (cm.)	H (cm.)				
269 / 593	720	180	270				

- Material: Powder coated steel - Color: Matte black
 - Steel tubes size: 60x60x3.5 mm. + 32x4 mm. round tubes.

* Above configuration is also available w/o English Ladder on top.

^{**} - Pull-Up heights: 6'10"-7'6"-8'3" (only w/12' Uprights)
 - Can be switched with: Double Cross Member (VSXFIT22/23)/Muscle-Up (VSXFIT28/21/36/37)
 /Offset Pull-Up Frame (VSXFIT01/06)/Offset Pull-Up Bar (VSXFIT35/36)
 - Pull-Up heights: 8'74"-6'10"

^{**3} The English Ladder Side Bar can be bolted at 8.74' (265 cm.) or 6'10" (207 cm.) off the ground.

XRIG™ configurations come disassembled.

ALL XRIG™ PRE-SET CONFIGS CAN BE FULLY CUSTOMIZED OR UPGRADED UP TO CUSTOMER'S REQUIREMENTS.

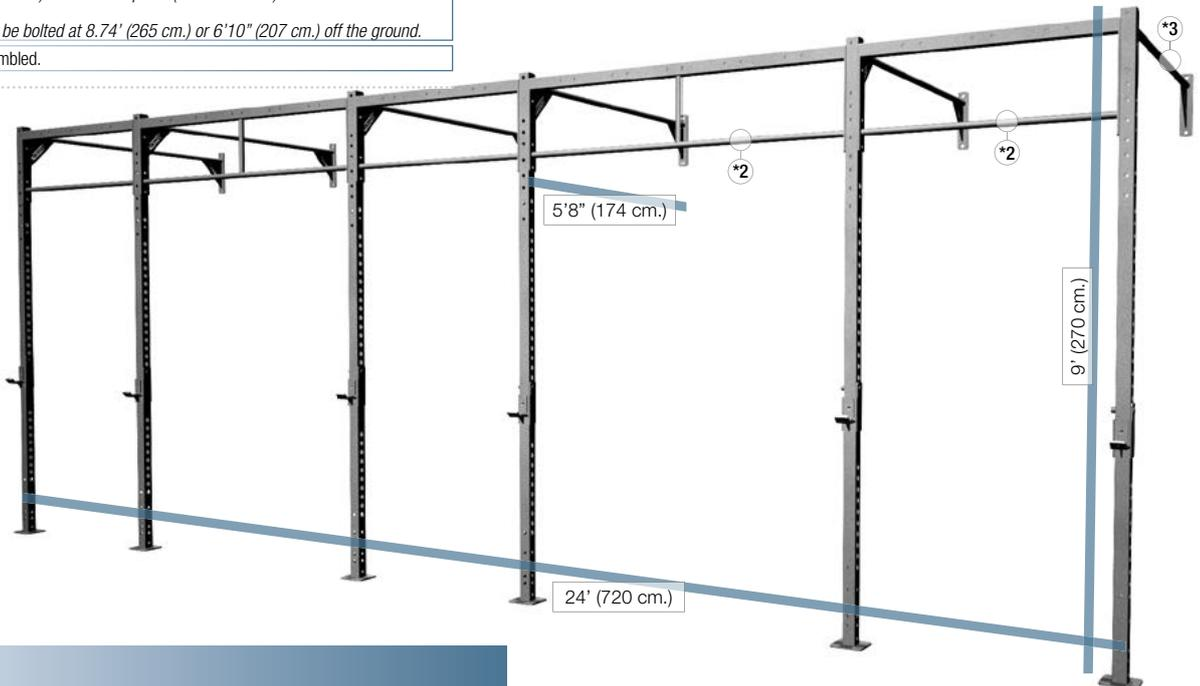

XRIG™ STATIONS

RKXFIT17 XRIG™ - RACK 4'x 6' x 9' - w/ Power Lifting Cage

- XRIG™ - 9' Basic Upright (270 cm.)x6PCs
- XRIG™ - 4' Basic Pull-Up frame (108 cm.)x2PCs
- XRIG™ - Power Bands Pegs Cross Member (To be used with Power Lifting Cage)x4PCs
- XRIG™ - Back Cross Member (To be used with Power Lifting Cage)x2PCs
- XRIG™ - Plates Sleeve - x6PCs
- XRIG™ - 2"x55" Nylon Safety Strap w/HD Carabiner (Max. Load 1200 Kg.) (to be used with Power Lifting Cage)x2PCs
- XRIG™ - Safety Strap Anchoring Tool - (to be used with Power Lifting Cage)x4PCs
- XRIG™ - Safety Spotter Arm - x2PCs
- XRIG™ - Bar J-Rack - x4PCs

WEIGHT (Kg./Lbs)	L (cm.)	W (cm.)	H (cm.)		
241 / 531	120	180	270		

- Material: Powder coated steel - Color: Matte black
 - Steel tubes size: 60x60x3.5 mm. + 32x4 mm. round tubes.

⚠ Should you got an XFIT Rack already, it can be upgraded to the Powerlifting Cage by using the "Powerlifting Cage-rack upgrade kit (VSXFIT17)".

^{**} - Pull-Up heights: 6'10"-7'6"-8'3" (only w/12' Uprights)
 - Can be switched with: Double Cross Member (VSXFIT22/23)/Muscle-Up (VSXFIT28/21/36/37)
 /Offset Pull-Up Frame (VSXFIT01/06)/Offset Pull-Up Bar (VSXFIT35/36)
 - Pull-Up heights: 8'74"-6'10"

XRIG™ configurations come disassembled.

ALL XRIG™ PRE-SET CONFIGS CAN BE FULLY CUSTOMIZED OR UPGRADED UP TO CUSTOMER'S REQUIREMENTS.

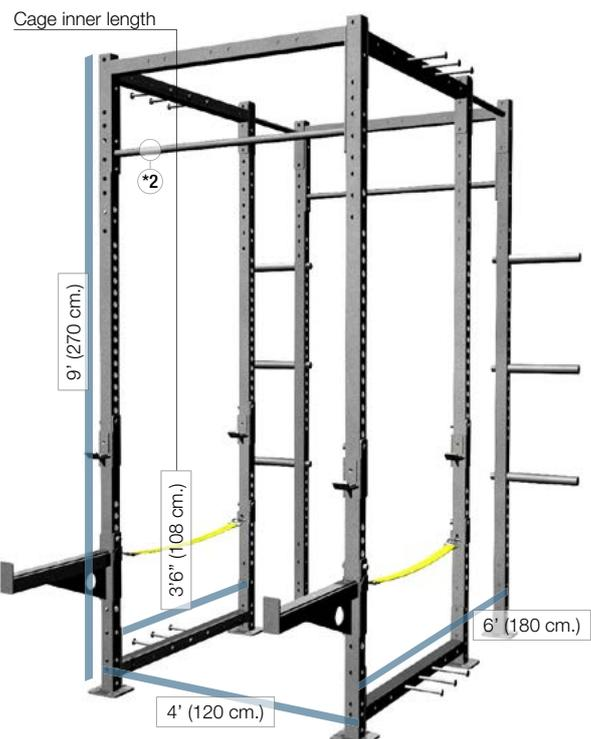



MAGNUM SERIES - XRIG™ STATIONS

RKXFIT17MS MAGNUM SERIES - XRIG™ - Big Boy Rack 4'x 6' x 9'

- w/Power Lifting Cage
- MAGNUM SERIES - XRIG™ - 9' Basic Upright (270 cm.) - 3.15" x 3.15" x 8 Gauge (8 x 8 cm. x 4 mm.) Oversize Steel Tube - x6PCs
- XRIG™ - 4' Basic Pull-Up frame (104 cm.) - M.S. (to be used with Magnum Series Rack)x2PCs
- XRIG™ - Power Bands Pegs Cross Member (to be used with Power Lifting Cage)x4PCs
- XRIG™ - Back Cross Member MS (to be used with RKXFIT17MS - BIG BOY - POWER LIFTING CAGE)x2PCs
- XRIG™ - Plates Sleeve - M.S. (to be used with Magnum Series Uprights)x6PCs
- MAGNUM SERIES - XRIG™ - Safety Strap Anchoring Tool - 8 Gauge (4 mm. steel thickness)x2PCs
- XRIG™ - 2"x55" Nylon Safety Strap w/HD Carabiner (Max.Load 1200 Kg.) (for XRIG POWER LIFTING CAGE)x2PCs
- MAGNUM SERIES - XRIG™ - Safety Spotter Arm - 8 Gauge (4 mm. steel thickness)x2PCs
- MAGNUM SERIES - XRIG™ - Bar J-Rack - 8 Gauge (4 mm. steel thickness)x4PCs

WEIGHT (Kg./Lbs)	L (cm.)	W (cm.)	H (cm.)
241 / 531	122	182	270

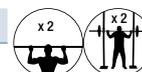

- Material: Powder coated steel - Color: Matte black
- Steel tubes size: 80x80x4 mm. + 32x4 mm. round tubes.

⚠ Should you got an XFIT Rack already, it can be upgraded to the Powerlifting Cage by using the "Powerlifting Cage-rack upgrade kit (VSXFIT17)".

- *2 - Pull-Up heights: 6'10"-7'6"-8'3" (only w/12' Uprights)
- Can be switched with: Double Cross Member (VSXFIT22/23)/Muscle-Up (VSXFIT28/21/36/37) /Offset Pull-Up Frame (VSAXFIT01/06)/Offset Pull-Up Bar (VSAXFIT35/36)
- Pull-Up heights: 8'74"-6'10"

XRIG™ configurations come disassembled.

ALL XRIG™ PRE-SET CONFIGS CAN BE FULLY CUSTOMIZED OR UPGRADED UP TO CUSTOMER'S REQUIREMENTS.

Cage inner length

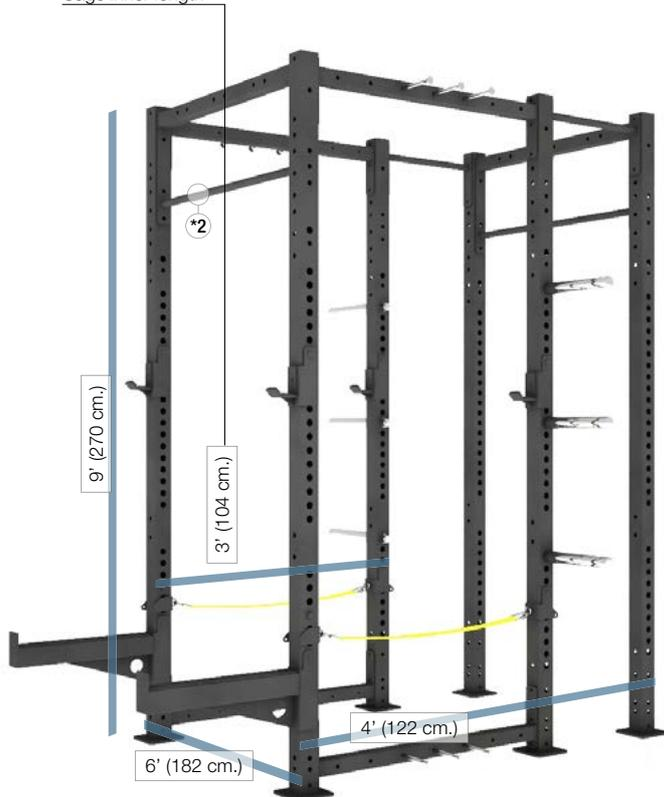

XRIG™ STATIONS

RKXFIT18 XRIG™ - RACK 4'x6'x9' - Wall Mounted - w/Power Lifting Cage

- XRIG™ - 9' Basic Upright (270 cm.)x4PCs
- XRIG™ - 4' Basic Pull-Up frame (108 cm.)x1PC
- XRIG™ - Power Bands Pegs Cross Member (To be used with Power Lifting Cage)x4PCs
- XRIG™ - Back Cross Member (to be used with Power Lifting Cage)x2PCs
- XRIG™ - Plates Sleeve - x6PCs
- XRIG™ - 2"x55" Nylon Safety Strap w/HD Carabiner (Max.Load 1200 Kg.) (to be used with Power Lifting Cage)x2PCs
- XRIG™ - Safety Strap Anchoring Tool - (to be used with Power Lifting Cage)x4PCs
- XRIG™ - Safety Spotter Arm - x2PCs
- XRIG™ - Bar J-Rack - x4PCs

WEIGHT (Kg./Lbs)	L (cm.)	W (cm.)	H (cm.)
188 / 414	120	180	270



- Material: Powder coated steel - Color: Matte black
- Steel tubes size: 60x60x3.5 mm. + 32x4 mm. round tubes.

⚠ Should you got an XFIT Rack already, it can be upgraded to the Powerlifting Cage by using the "Powerlifting Cage-rack upgrade kit (VSXFIT17)".

- *2 - Pull-Up heights: 6'10"-7'6"-8'3" (only w/12' Uprights)
- Can be switched with: Double Cross Member (VSXFIT22/23)/Muscle-Up (VSXFIT28/21/36/37) /Offset Pull-Up Frame (VSAXFIT01/06)/Offset Pull-Up Bar (VSAXFIT35/36)
- Pull-Up heights: 8'74"-6'10"

XRIG™ configurations come disassembled.

ALL XRIG™ PRE-SET CONFIGS CAN BE FULLY CUSTOMIZED OR UPGRADED UP TO CUSTOMER'S REQUIREMENTS.

Cage inner length



XRIG™ STATIONS

XRIG™ STATIONS

RKXFIT19 XRIG™ - RIG + RACK 10'x 6' x 9' - w/Power Lifting Cage

- XRIG™ - 9' Basic Upright (270 cm.)x8PCs
- XRIG™ - 4' Basic Pull-Up frame (108 cm.)x2PCs
- XRIG™ - 6' Basic Pull-Up frame (168 cm.)x2PCs
- XRIG™ - 6' English Ladder Side-Bar (180 cm.)x1PC
- XRIG™ - Power Bands Pegs Cross Member (To be used with Power Lifting Cage)x4PCs
- XRIG™ - Back Cross Member (to be used with Power Lifting Cage)x2PCs
- XRIG™ - Plate Sleeve - x6PCs
- XRIG™ - 2"x55" Nylon Safety Strap w/HD Carabiner (Max.Load 1200 Kg.) (to be used with Power Lifting Cage)x2PCs
- XRIG™ - Safety Strap Anchoring Tool - (to be used with Power Lifting Cage)x4PCs
- XRIG™ - Safety Spotter Arm - x2PCs
- XRIG™ - Bar J-Rack - x4PCs

WEIGHT (Kg./Lbs)	L (cm.)	W (cm.)	H (cm.)				
329 / 725	300	180	270	x8	x1	x1	x2

- Material: Powder coated steel - Color: Matte black
 - Steel tubes size: 60x60x3.5 mm. + 32x4 mm. round tubes.

⚠ Should you got an XFIT Rack already, it can be upgraded to the Powerlifting Cage by using the "Powerlifting Cage-rack upgrade kit (VSXFIT17)".

*2 - Pull-Up heights: 6'10"-7'6"-8'3" (only w/12' Uprights)
 - Can be switched with: Double Cross Member (VSXFIT22/23)/Muscle-Up (VSXFIT28/21/36/37) /Offset Pull-Up Frame (VSXFIT01/06)/Offset Pull-Up Bar (VSXFIT35/36)
 - Pull-Up heights: 8'74"-6'10"

*3 The English Ladder Side Bar can be bolted at 8.74' (265 cm.) or 6'10" (207 cm.) off the ground.

XRIG™ configurations come disassembled.

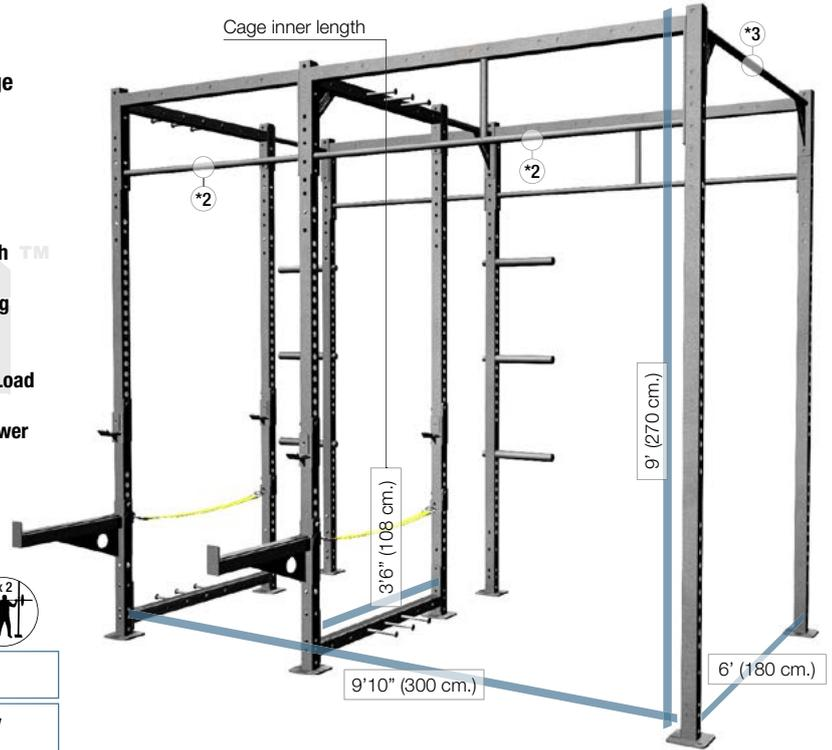

ALL XRIG™ PRE-SET CONFIGS CAN BE FULLY CUSTOMIZED OR UPGRADED UP TO CUSTOMER'S REQUIREMENTS.



XRIG™ STATIONS

RKXFIT20 XRIG™ - OCTAGONAL WORKOUT STATION 15'3" x 14'8" x 10'8"

- XRIG™ - 9' Basic Upright (270 cm.)x8PCs
- XRIG™ - 4' Offset Pull-Up Frame (108 cm.)x1PC
- XRIG™ - 6' Basic Pull-Up frame (168 cm.)x2PCs
- XRIG™ - 4' Offset Pull-Up Frame (108 cm.)x2PCs
- XRIG™ - 6' Offset Wing Ladder (168 cm.)x1PC
- XRIG™ - Short Corner Bar - x3PCs
- XRIG™ - Short Corner Bar for Boxing Bag Arm mounting - x1PC
- XRIG™ - 11' Junction Bar - x2PCs
- XRIG™ - 4' Ladder Bar - x10PCs
- XRIG™ - Dip Horns - x1PC
- XRIG™ - Step-Up Platform - x1PC
- XRIG™ - Safety Spotter Arm - x2PCs
- XRIG™ - Bar J-Rack - x4PCs
- XRIG™ - Boxing Bag Arm - x1PC
- XRIG™ - Back-Bone-Like Boxing Bag (100 cm. length -36 cm. dia. - 30 Kg.) - Carbon-look "BTEX" Fabric - 2IM antifire class certified - Black Color (Chains, Swivel hook and Carabiner included)x1PC
- XRIG™ - Wall Ball Target - x1PC
- XRIG™ - Core Trainer Fulcrum - x2PCs
- XRIG™ - Training Rope Anchoring Ring - x2PCs
- XRIG™ - Carabiner Anchoring Tool - x2PCs

WEIGHT (Kg./Lbs)	L (cm.)	W (cm.)	H (cm.)
583 / 1285	465	446	326



- Material: Powder coated steel - Color: Matte black
 - Steel tubes size: 60x60x3.5 mm. + 32x4 mm. round tubes.

*2 - Pull-Up heights: 6'10"-7'6"-8'3" (only w/12' Uprights)
 - Can be switched with: Double Cross Member (VSXFIT22/23)/Muscle-Up (VSXFIT28/21/36/37)
 /Offset Pull-Up Frame (VSXFIT01/06)/Offset Pull-Up Bar (VSXFIT35/36)
 - Pull-Up heights: 8'74"-6'10"

XRIG™ configurations come disassembled.

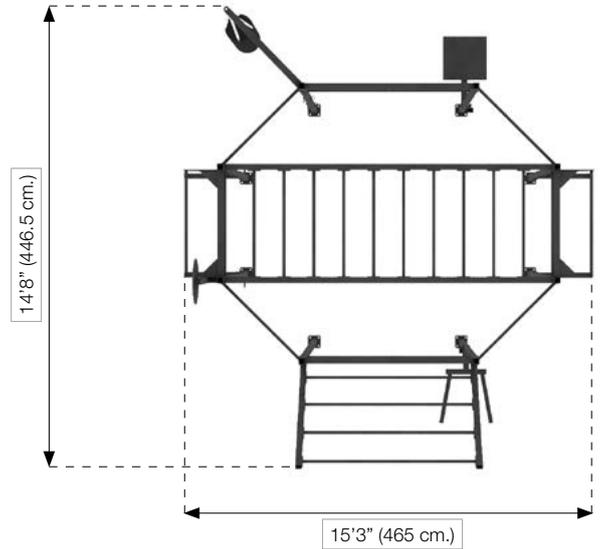

ALL XRIG™ PRE-SET CONFIGS CAN BE FULLY CUSTOMIZED OR UPGRADED UP TO CUSTOMER'S REQUIREMENTS.



XRIG™ STATIONS

RKXFIT21 XRIG™ - OCTAGONAL TEAM WORKOUT STATION

26'8" x 21'5" x 12'

- XRIG™ - 9' Basic Upright (270 cm.) x 16PCs
- XRIG™ - 12' Basic Upright (360 cm.) x 4PCs
- XRIG™ - 4' Basic Pull-Up frame (108 cm.) x 2PCs
- XRIG™ - 6' Basic Pull-Up frame (168 cm.) x 2PCs
- XRIG™ - 4' Offset Pull-Up Frame (108 cm.) x 2PCs
- XRIG™ - 6' English Ladder Side-Bar (168 cm.) x 8PCs
- XRIG™ - 6' Junction Bar (168 cm.) x 2PCs
- XRIG™ - Short Corner Bar - x4PCs
- XRIG™ - Long Corner Bar - x7PCs
- XRIG™ - Long Corner Bar for Boxing Bag Arm mounting - x1PC
- XRIG™ - 11' Junction Bar - x2PCs
- XRIG™ - 4' Ladder Bar - x10PCs
- XRIG™ - Dip Horns - x1PCs
- XRIG™ - Step-Up Platform - x1PC
- XRIG™ - Safety Spotter Arm - x2PCs
- XRIG™ - Bar J-Rack - x4PCs
- XRIG™ - Boxing Bag Arm - x1PC
- XRIG™ - Back-Bone-Like Boxing Bag (100 cm. length - 36 cm. dia. - 30 Kg.) - Carbon-look "BTEX" Fabric - 2IM antifire class certified - Black Color (Chains, Swivel hook and Carabiner included) x1PC
- XRIG™ - Wall Ball Target - x1PC
- XRIG™ - Core Trainer Fulcrum - x2PCs
- XRIG™ - Training Rope Anchoring Ring - x2PCs
- XRIG™ - Carabiner Anchoring Tool - x2PCs

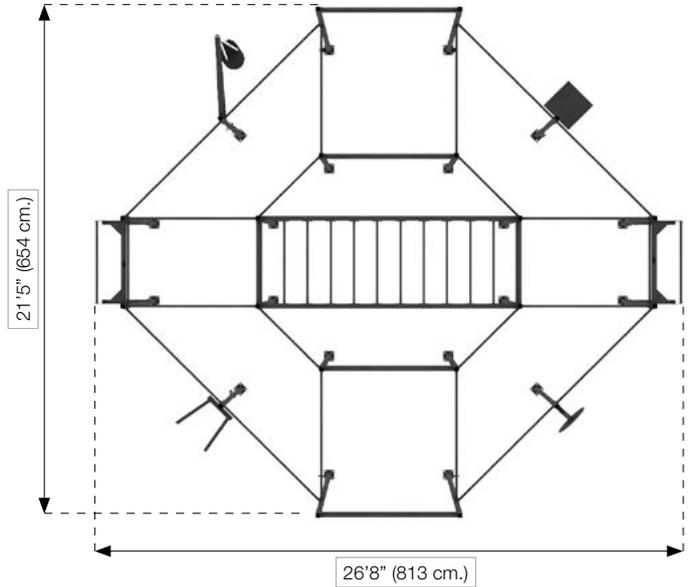

WEIGHT (Kg./Lbs)	L (cm.)	W (cm.)	H (cm.)				
992.5 / 2188	813	654	366				

- Material: Powder coated steel - Color: Matte black
 - Steel tubes size: 60x60x3.5 mm. + 32x4 mm. round tubes.

*2 - Pull-Up heights: 6'10" - 7'6" - 8'3" (only w/12' Uprights)
 - Can be switched with: Double Cross Member (VSXFIT22/23)/Muscle-Up (VSXFIT28/21/36/37)
 /Offset Pull-Up Frame (VSAXFIT01/06)/Offset Pull-Up Bar (VSAXFIT35/36)
 - Pull-Up heights: 8'74" - 6'10"

XRIG™ configurations come disassembled.

ALL XRIG™ PRE-SET CONFIGS CAN BE FULLY CUSTOMIZED OR UPGRADED UP TO CUSTOMER'S REQUIREMENTS.



XRIG™ STATIONS

RKXFIT22 XRIG™ - CONTEST RIG - 10 ATHLETES x 5 SPECIALTIES

- XRIG™ - 9' Basic Upright (270 cm.)x11PCs
- XRIG™ - 12' Basic Upright (360 cm.)x22PCs
- XRIG™ - 6' Xenios USA Laser Cut Logo Panel (168 cm.)x5PCs
- XRIG™ - 6' Base Crossmember (180 cm.)x16PCs
- XRIG™ - 4' English Ladder Bar (108 cm.)x11PCs
- XRIG™ - 6' Junction Bar (168 cm.)x41PCs
- XRIG™ - 4' Junction Bar (108 cm.)x11PCs
- XRIG™ - Basic Upright Extension kit + 52.7" (134 cm.)x6KIT
- 1.5" x 20' Natural Fiber Climbing Rope - 38 mm. x 6 m. (rope eyelet included)x10PCs
- XRIG™ - HandStand Board Kit - x10KIT
- XRIG™ - Athlete Lane Marker Dish (w/magnets)x10PCs
- XRIG™ - Junction Bar Anchoring Tool for Rings and Rope w/carabiner and swivels - x25BOX
- 1.25" Gymnastic Wood Ring (32mm.) grip - 300 Kg. Tested - x20BOX
- 16.4' Heavy duty Strap Anchor w/cam-buckle - (5 m.)x10BOX
- 6' Competition Strap for Gymnastic Rings w/carabiners - (185 cm.)x10BOX
- XRIG™ - 6' Offset Pull-Up Bar (168 cm.)x20PCs
- XRIG™ - Offset Double Wall Ball Target - x5PCs

WEIGHT (Kg./Lbs)	L (cm.)	W (cm.)	H (cm.)
837.5 / 1846	1140	342	500

- Material: Powder coated steel - Color: Matte black
 - Steel tubes size: 60x60x3.5 mm. + 32x4 mm. round tubes.

*2 - Pull-Up heights: 6'10"-7'6"-8'3" (only w/12' Uprights)
 - Can be switched with: Double Cross Member (VSXFIT22/23)/Muscle-Up (VSXFIT28/21/36/37)
 /Offset Pull-Up Frame (VSXFIT01/06)/Offset Pull-Up Bar (VSXFIT35/36)
 - Pull-Up heights: 8'74"-6'10"

Configuration for 10 athletes. The here in represented stands for 1 athlete only.

XRIG™ configurations come disassembled.

ALL XRIG™ PRE-SET CONFIGS CAN BE FULLY CUSTOMIZED OR UPGRADED UP TO CUSTOMER'S REQUIREMENTS.

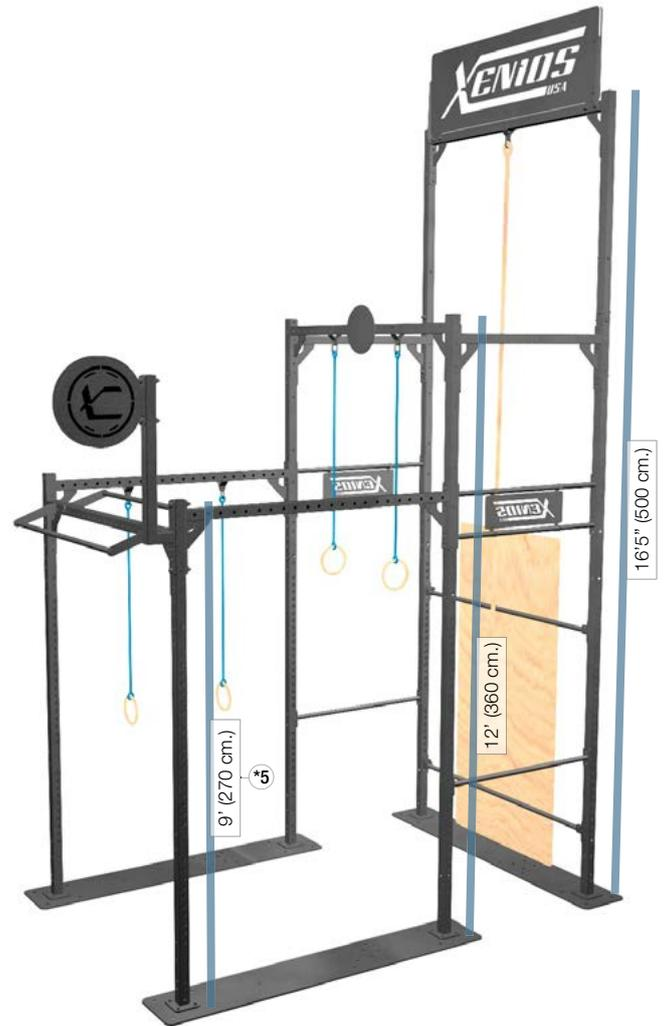

1 STATION = 1 ATHLETE LANE

- PULL-UP / MUSCLE-UP WOD
- ANY GYM RINGS WOD
- CLIMBING ROPE WOD
- HAND STAND BOARD WOD
- WALL BALL WOD

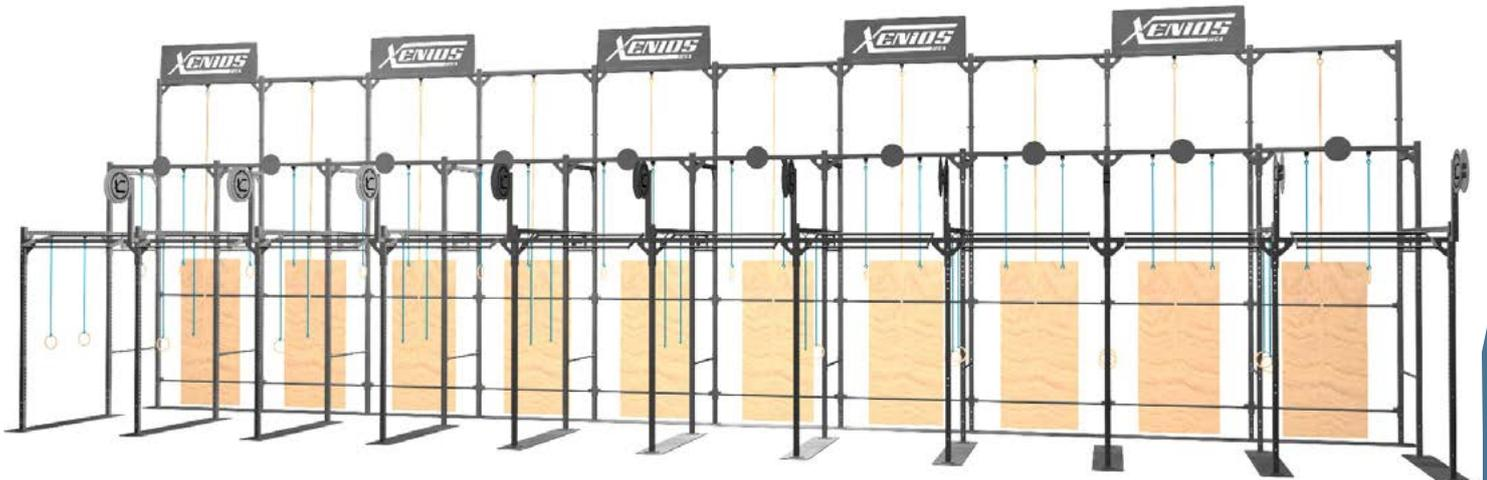

XRIG™ STATIONS

RKXFIT23 XRIG™ - CALISTHENICS PLAYGROUND

- XRIG™ - 9' Basic Upright (270 cm.)x9PCs
- XRIG™ - 6' English Ladder Side-Bar (168 cm.)x1PC
- XRIG™ - 6' English Ladder Bar (168 cm.)x2PCs
- XRIG™ - 6' Muscle-Up Bar (168 cm.)x3PCs
- XRIG™ - 4' English Ladder Bar (108 cm.)x11PCs
- XRIG™ - 4' Pull-Up Double Crossmember (108 cm.)x2PCs
- XRIG™ - 11' Junction Bar - x2PCs
- XRIG™ - 4' Vertical Ladder Kit (118 cm.)x1KIT
- XRIG™ - 3" Strongmen Pull-Up Marble (8 cm.)x4PCs
- XRIG™ - 5" Strongmen Pull-Up Marble (13 cm.)x4PCs
- Calisthenics Parallel Bars - x1KIT
- XRIG™ - 3' Base Crossmember (90 cm.)x2PCs

1'9" (55 cm.)



7'10" (240 cm.)

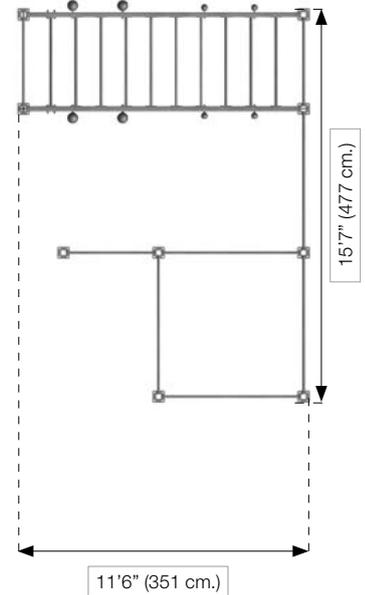

11'6" (351 cm.)

15'7" (477 cm.)

WEIGHT (Kg./Lbs)	L (cm.)	W (cm.)	H (cm.)				
458 / 1009	477	351	270				

- Material: Powder coated steel - Color: Matte black
 - Steel tubes size: 60x60x3.5 mm. + 32x4 mm. round tubes.

XRIG™ configurations come disassembled.

ALL XRIG™ PRE-SET CONFIGS CAN BE FULLY CUSTOMIZED OR UPGRADED UP TO CUSTOMER'S REQUIREMENTS.



5' (153 cm.)

9' (270 cm.)



XRIG™ STATIONS

RKXFIT24 XRIG™ - CALISTHENICS PLAYGROUND ADVANCED

- XRIG™ - 9' Basic Upright (270 cm.)x11PCs
- XRIG™ - 6' English Ladder Side-Bar (168 cm.)x1PC
- XRIG™ - 6' English Ladder Bar (168 cm.)x2PCs
- XRIG™ - 6' Muscle-Up Bar (168 cm.)x6PCs
- XRIG™ - 4' English Ladder Bar (108 cm.)x10PCs
- XRIG™ - 4' Pull-Up Double Crossmember (108 cm.)x2PCs
- XRIG™ - 11' Junction Bar - x2PCs
- XRIG™ - 4' Vertical Ladder Kit (118 cm.)x1KIT
- XRIG™ - 6' Offset Wing Ladder - 4 steps (180 cm.)x1KIT
- XRIG™ - Offset Calisthenics Parallel Bars
- Attachment - Rig Front mounted - Double Dip - x1KIT
- XRIG™ - 3" Strongmen Pull-Up Marble (8 cm.)x4PCs
- XRIG™ - 5" Strongmen Pull-Up Marble (13 cm.)x4PCs

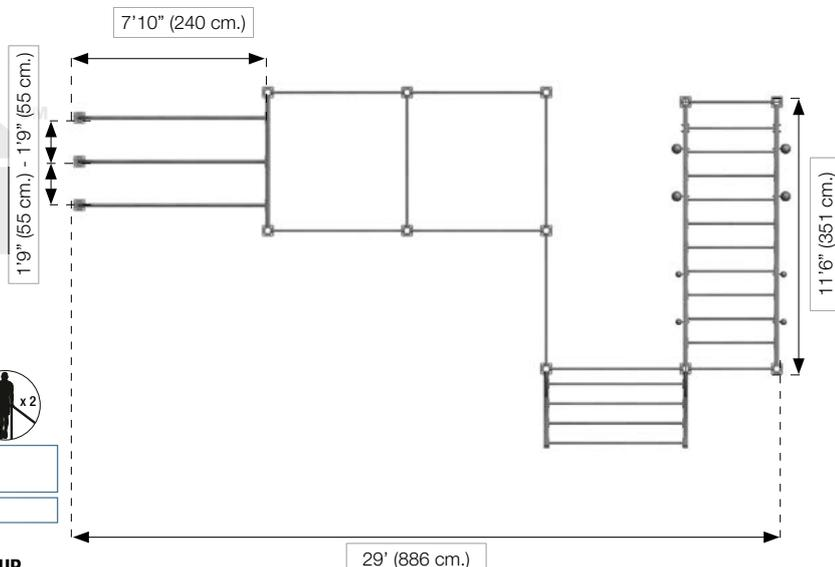

WEIGHT (Kg./Lbs)	L (cm.)	W (cm.)	H (cm.)				
500 / 1102	886	351	326				

- Material: Powder coated steel - Color: Matte black
 - Steel tubes size: 60x60x3.5 mm. + 32x4 mm. round tubes.

XRIG™ configurations come disassembled.

ALL XRIG™ PRE-SET CONFIGS CAN BE FULLY CUSTOMIZED OR UPGRADED UP TO CUSTOMER'S REQUIREMENTS.



XRIG™ STATIONS

RKXFIT25 XRIG™ - STREET WORKOUT CAGE

- XRIG™ - 9' Basic Upright (270 cm.)x4PCs
- XRIG™ - 6' Muscle-Up Bar (168 cm.)x2PCs
- XRIG™ - 6' Pull-Up Double Crossmember (108 cm.)x2PCs
- XRIG™ - 6' Vertical Ladder Kit (168 cm.)x1PC
- XRIG™ - Offset Calisthenics Parallel Bars Attachment - Rig - Front mounted - Double Dip - x1PC

WEIGHT (Kg./Lbs)	L (cm.)	W (cm.)	H (cm.)	 x 4	 x 4	 x 2	 x 2
197 / 434	424.5	189	270				

- Material: Powder coated steel - Color: Matte black
 - Steel tubes size: 60x60x3.5 mm. + 32x4 mm. round tubes.

XRIG™ configurations come disassembled.

ALL XRIG™ PRE-SET CONFIGS CAN BE FULLY CUSTOMIZED OR UPGRADED UP TO CUSTOMER'S REQUIREMENTS.

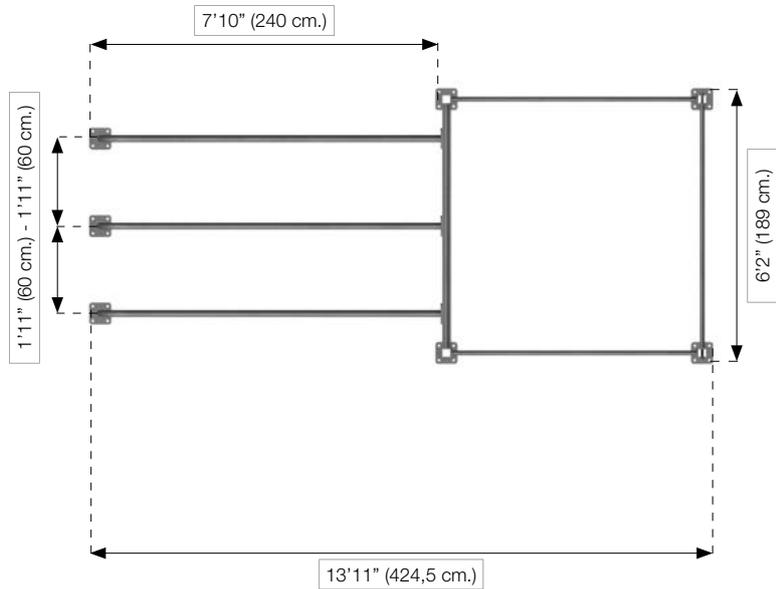

XRIG™ STATIONS

RKXFIT26 XRIG™ - STREET WORKOUT TEAM CAGE

- XRIG™ - 9' Basic Upright (270 cm.)x8PCs
- XRIG™ - 6' Muscle-Up Bar (168 cm.)x8PCs
- XRIG™ - 6' Pull-Up Double Crossmember (108 cm.)x2PCs
- XRIG™ - 6' Offset Wing Ladder - 4 steps (180 cm.)x1PC
- XRIG™ - Offset Calisthenics Parallel Bars Attachment - Rig Front mounted - Double Dip - x1PC

WEIGHT (Kg./Lbs)	L (cm.)	W (cm.)	H (cm.)				
317 / 698	537	424.5	326				

- Material: Powder coated steel - Color: Matte black
 - Steel tubes size: 60x60x3.5 mm. + 32x4 mm. round tubes.

XRIG™ configurations come disassembled.

ALL XRIG™ PRE-SET CONFIGS CAN BE FULLY CUSTOMIZED OR UPGRADED UP TO CUSTOMER'S REQUIREMENTS.

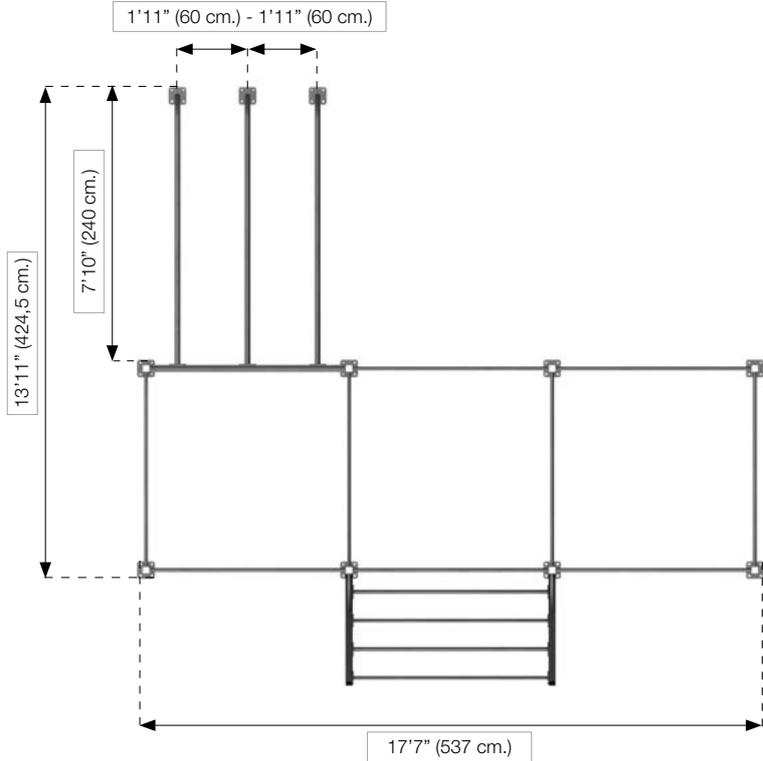

XRIG™ STATIONS

RKXFIT27 XRIG™ - STREET WORKOUT & POWER LIFTING CAGE

- XRIG™ - 9' Basic Upright (270 cm.)x6PCs
- XRIG™ - 6' English Ladder Side-Bar (168 cm.)x1PC
- XRIG™ - 4' English Ladder Bar (168 cm.)x5PCs
- XRIG™ - 4' Muscle-Up Bar (108 cm.)x2PCs
- XRIG™ - 4' Pull-Up Double Crossmember (108 cm.)x2PCs
- XRIG™ - 6' Junction Bar (168 cm.)x2PCs
- XRIG™ - 4' Vertical Ladder Kit (118 cm.)x1KIT
- XRIG™ - Bar J-Rack - x2PCs
- XRIG™ - Safety Spotter Arm - x2PCs
- XRIG™ - Plates Sleeve - x8PCs

WEIGHT (Kg./Lbs)	L (cm.)	W (cm.)	H (cm.)	
286 / 630	273.5	245.8	270	x4

- Material: Powder coated steel - Color: Matte black
- Steel tubes size: 60x60x3.5 mm. + 32x4 mm. round tubes.

XRIG™ configurations come disassembled.

ALL XRIG™ PRE-SET CONFIGS CAN BE FULLY CUSTOMIZED OR UPGRADED UP TO CUSTOMER'S REQUIREMENTS.

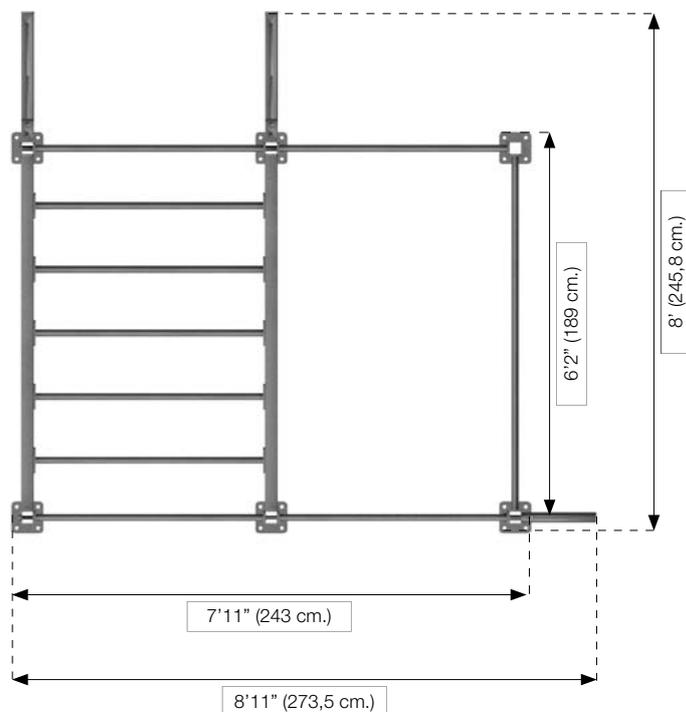

XRIG™ STATIONS

RKXFIT28 XRIG™ - STREET WORKOUT PRO CAGE

- XRIG™ - 9' Basic Upright (270 cm.)x9PCs
- XRIG™ - 12' Basic Upright (360 cm.)x2PCs
- XRIG™ - 6' Muscle-Up Bar (168 cm.)x5PCs
- XRIG™ - 6' English Ladder Bar (168 cm.)x10PCs
- XRIG™ - 6' Basic Pull-Up frame (168 cm.)x2PCs
- XRIG™ - 6' Junction Bar (168 cm.)x7PCs
- XRIG™ - Offset Gym Rings Station - x1PCs
- XRIG™ - XRIG™ - Junction Bar Anchoring Tool for Rings and Rope w/carabiners and swivel - x4PCs
- XRIG™ - 6' Offset Wing Ladder - 4 steps (180 cm.) - x1KIT
- XRIG™ - Offset Calisthenics Parallel Bars Attachment - Rig Front mounted - Double Dip - x2KIT
- XRIG™ - 6' Offset Pull-Up Bar (137 cm.)x2PCs
- XRIG™ - Plates Sleeve - x8PCs
- XRIG™ - Dip Horns - x1PC
- XRIG™ - Step-Up Platform - x1PC
- XRIG™ - 5" Strongmen Pull-Up Marble (13 cm.)x4PCs
- XRIG™ - 3" Strongmen Pull-Up Marble (8 cm.)x4PCs
- XRIG™ - Front-grip Pull-up Handle - x2PCs
- Gymnastic-1.25 Wood Ring 1.25" (32mm. grip) thick - 300 Kg. Tested - x2PAIR
- 16.4' Heavy duty Strap Anchor w/cam-buckle - (500 cm.)x2PAIR

WEIGHT (Kg./Lbs)	L (cm.)	W (cm.)	H (cm.)			
588 / 1296	1296	363	366			

- Material: Powder coated steel - Color: Matte black
 - Steel tubes size: 60x60x3.5 mm. + 32x4 mm. round tubes.
 XRIG™ configurations come disassembled.

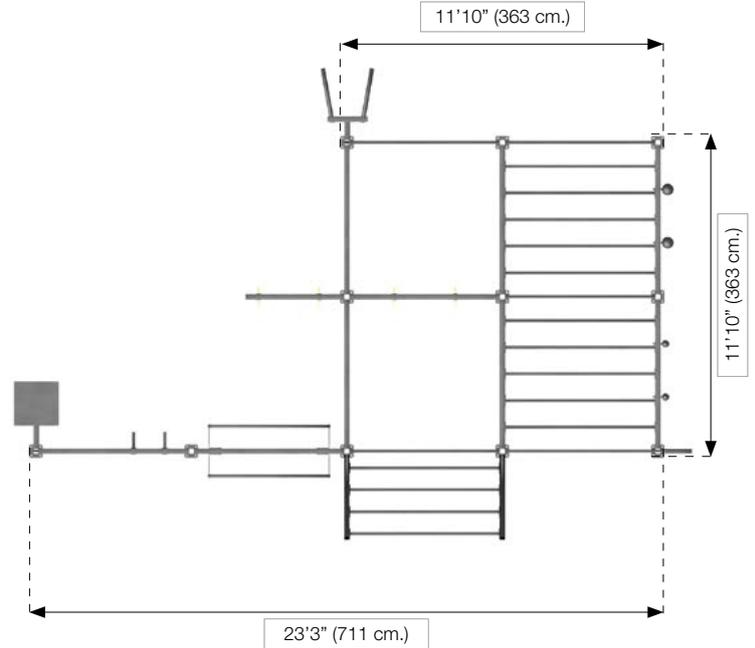

ALL XRIG™ PRE-SET CONFIGS CAN BE FULLY CUSTOMIZED OR UPGRADED UP TO CUSTOMER'S REQUIREMENTS.

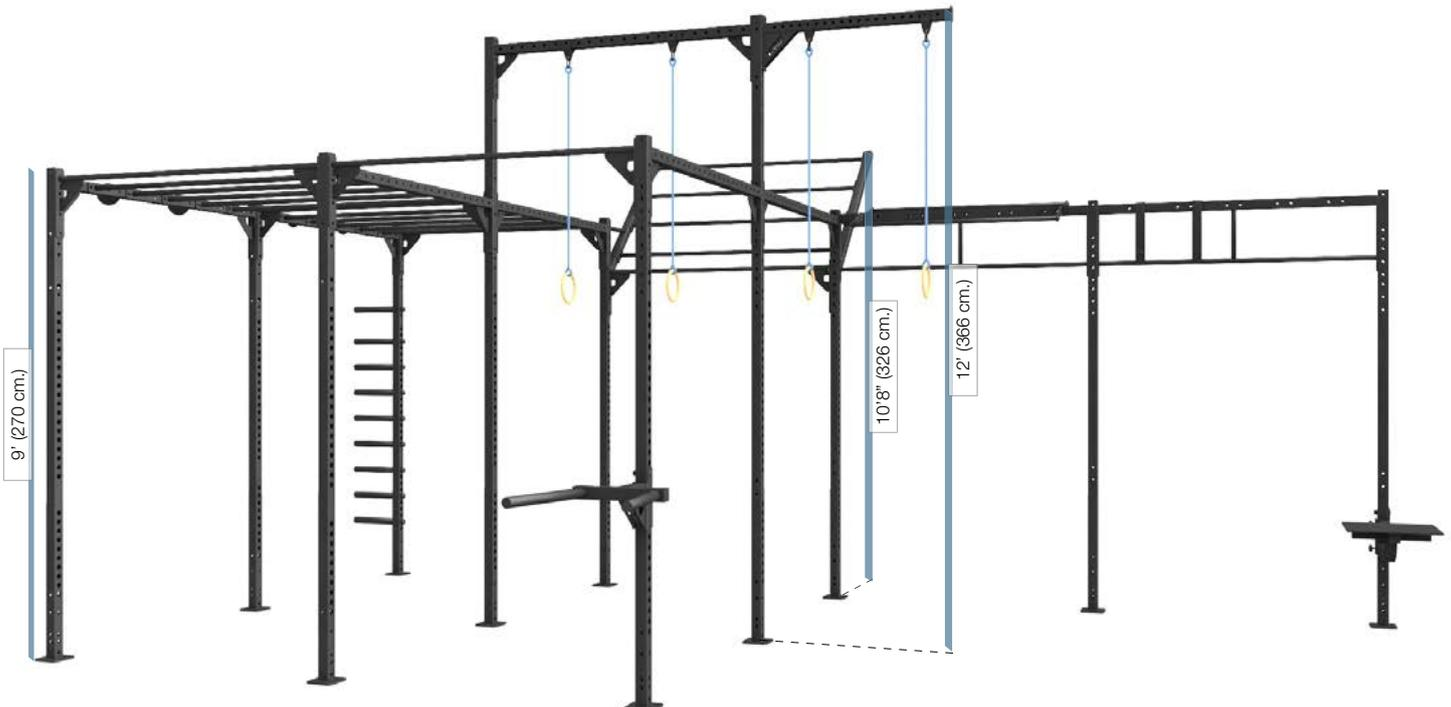

XRIG™ STATIONS

RKXFIT29 XRIG™ - STREET WORKOUT PATH

- XRIG™ - 9' Basic Upright (270 cm.)x16PCs
- XRIG™ - 6' English Ladder Side-Bar (168 cm.)x2PCs
- XRIG™ - 6' English Ladder Bar (168 cm.)x16PCs
- XRIG™ - 4' Muscle-Up Bar (108 cm.)x4PCs
- XRIG™ - 6' Muscle-Up Bar (168 cm.)x2PCs
- XRIG™ - 4' Pull-Up Double Crossmember (108 cm.)x1PC
- XRIG™ - 6' Junction Bar (168 cm.)x5PCs
- XRIG™ - 4' Vertical Ladder Kit (118 cm.)x1KIT
- XRIG™ - Offset Calisthenics Parallel Bars Attachment - Rig Front mounted - Double Dip - x2KIT
- XRIG™ - 6' Offset Pull-Up Bar (137 cm.)x2PCs

WEIGHT (Kg./Lbs)	L (cm.)	W (cm.)	H (cm.)				
654 / 1441	1350	537	270				

- Material: Powder coated steel - Color: Matte black
 - Steel tubes size: 60x60x3.5 mm. + 32x4 mm. round tubes.
 XRIG™ configurations come disassembled.

ALL XRIG™ PRE-SET CONFIGS CAN BE FULLY CUSTOMIZED OR UPGRADED UP TO CUSTOMER'S REQUIREMENTS.

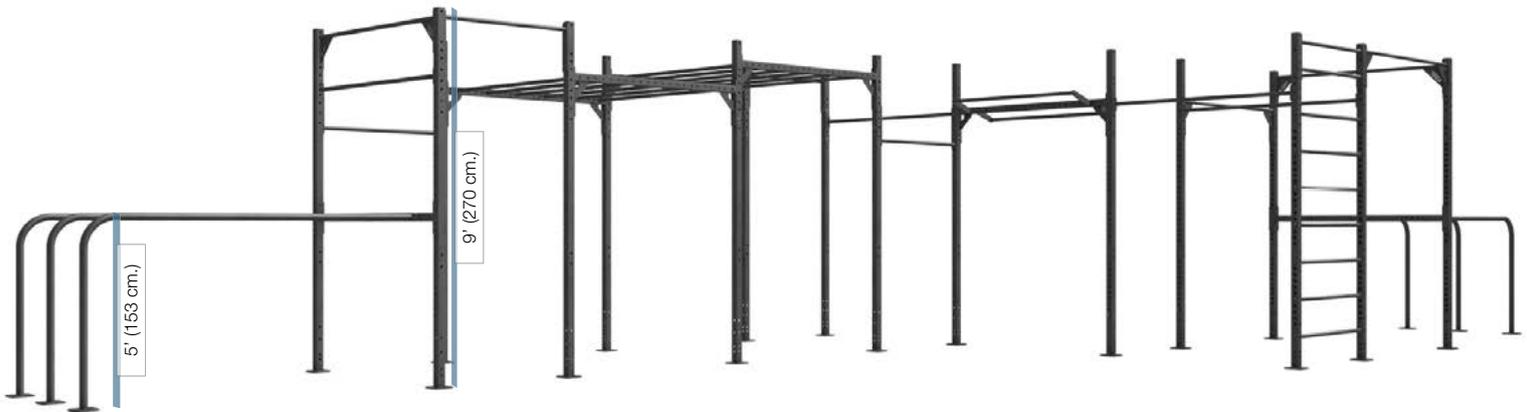
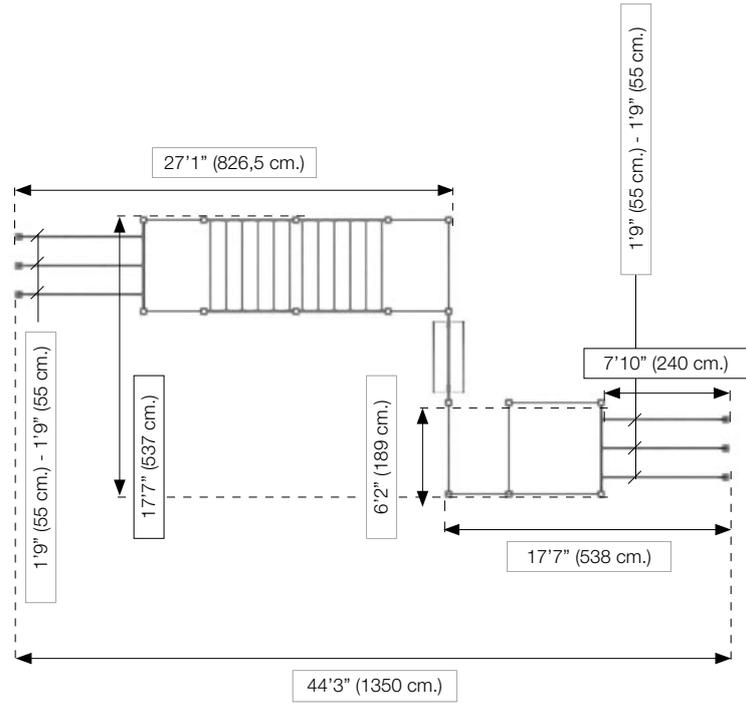

XRIG™ - PARTS AND OPTIONS

VSFXFIT17 XRIG™ - Power Lifting Cage - Upgrade Kit for XRIG™ RACK Configs (Stand Alone / Wall Mounted)

- XRIG™ - 9' Basic Upright (270 cm.)x2PCs
- XRIG™ - Power Bands Pegs Cross Member (to be used with Power Lifting Cage)x4PCs
- XRIG™ - Back Cross Member (to be used with Power Lifting Cage)x2PCs
- XRIG™ - Plates Support Sleeve - x6PCs
- XRIG™ - 2"x55" Nylon Safety Strap w/HD Carabiner (Max.Load 1200 Kg.) (for XRIG™ Power Lifting Cage)x2PCs
- XRIG™ - Hook for 2"x55" Nylon Safety Strap w/HD Carabiner (Max.Load 1200 Kg.) (for XRIG™ Power Lifting Cage)x4PCs
- XRIG™ - Safety Spotter Arm - x2PCs
- XRIG™ - Bar J-Rack - x2PCs

WEIGHT (Kg./Lbs)	L (cm.)	W (cm.)	H (cm.)				
127 / 280	120	120	270				

- Material: Powder coated steel - Color: Matte black
 - Steel tubes size: 60x60x3.5 mm. + 32x4 mm. round tubes.



VSFXFIT39 XRIG™ - Offset Power Lifting Cage - Upgrade Kit for XRIG™ RACK Configs (Stand Alone / Wall Mounted)

- XRIG™ - 9' Basic Upright (270 cm.) - x2PCs
- XRIG™ - Power Bands Pegs Cross Member (to be used with Power Lifting Cage) - x4PCs
- XRIG™ - Back Cross Member (to be used with Power Lifting Cage)- x2PCs
- XRIG™ - Plates Support Sleeve - x6PCs
- XRIG™ - 2"x55" Nylon Safety Strap w/HD Carabiner (Max.Load 1200 Kg.) (for XRIG™ Power Lifting Cage) - x2PCs
- XRIG™ - Hook for 2"x55" Nylon Safety Strap w/HD Carabiner (Max.Load 1200 Kg.) (for XRIG™ Power Lifting Cage) - x4PCs
- XRIG™ - Safety Spotter Arm - x2PCs
- XRIG™ - Bar J-Rack - x2PCs

WEIGHT (Kg./Lbs)	L (cm.)	W (cm.)	H (cm.)				
127 / 280	120	120	270				

- Material: Powder coated steel - Color: Matte black
 - Steel tubes size: 60x60x3.5 mm. + 32x4 mm. round tubes.



XRIG™ - PARTS AND OPTIONS

VSFXFIT03 XRIG™ - 9' Basic Upright

WEIGHT (Kg./Lbs)	L (cm.)	W (cm.)	H (cm.)
40 / 88	15	15	270

- Material: Powder coated steel - Color: Matte black
- Steel tubes size: 60x60x3.5 mm. - Base: 15x15x1 cm.
- Come either as a pair or as a pc, according to customers' needs.



PRE-DRILLED BASE TO BE SCREWED-IN TO CONCRETE

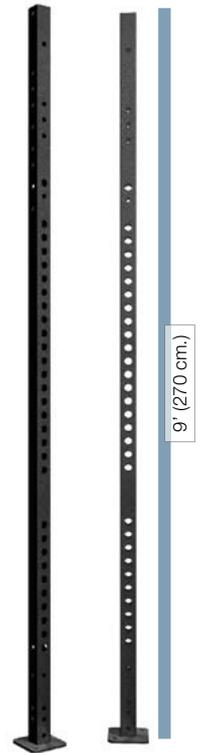

VSFXFIT03MS MAGNUM SERIES - XRIG™ - 9' Basic Upright (270 cm.) - 3.15" x 3.15" x 8 Gauge (8 x 8 cm. x 4 mm.) Oversize Steel Tube

WEIGHT (Kg./Lbs)	L (cm.)	W (cm.)	H (cm.)
50 / 110	30	30	271

- Material: Powder coated steel - Color: Matte black
- Steel tubes size: 80x80x4 mm. - Base: 15x15x1 cm.

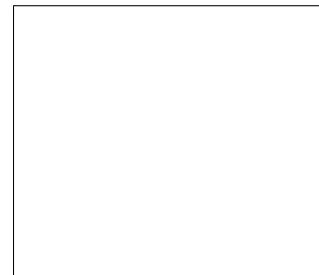

9' (271 cm.)



XRIG™ - PARTS AND OPTIONS

VSFxFIT16 XRIG™ - 12' Basic Upright

WEIGHT (Kg./Lbs)	L (cm.)	W (cm.)	H (cm.)
50 / 110	15	15	366

- Material: Powder coated steel - Color: Matte black
- Steel tubes size: 60x60x3.5 mm. - Base: 15x15x1 cm.
- Come either as a pair or as a pc, according to customers' needs.



PRE-DRILLED BASE TO BE SCREWED-IN TO CONCRETE

12' (366 cm.)

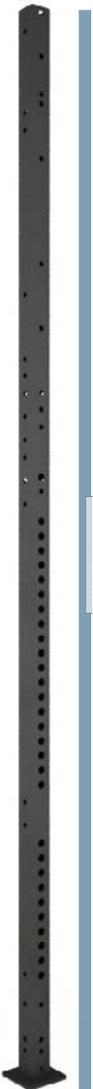
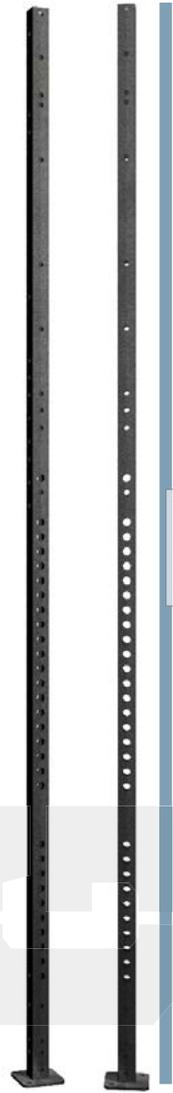

12' (366 cm.)



VSFxFIT16MS MAGNUM SERIES - XRIG™ - 12' Basic Upright (366 cm.) - 3.15" x 3.15" x 8 - Gauge (8 x 8 cm. x 4 mm.) Oversize Steel Tube

WEIGHT (Kg./Lbs)	L (cm.)	W (cm.)	H (cm.)
60 / 132	30	30	366

- Material: Powder coated steel - Color: Matte black
- Steel tubes size: 80x80x4 mm. - Base: 30x30x1 cm.

XRIG™ - PARTS AND OPTIONS

VSFxFIT35 XRIG™ - Basic Upright Extension kit +52.7" (134 cm.)

WEIGHT (Kg./Lbs)	L (cm.)	W (cm.)	H (cm.)
18 / 39	134	30	271

- Material: Powder coated steel - Color: Matte black
- Steel tubes size: 60x60x3 mm. - Base: 15x15x1 cm.
- Come either as a pair or as a pc, according to customers' needs.

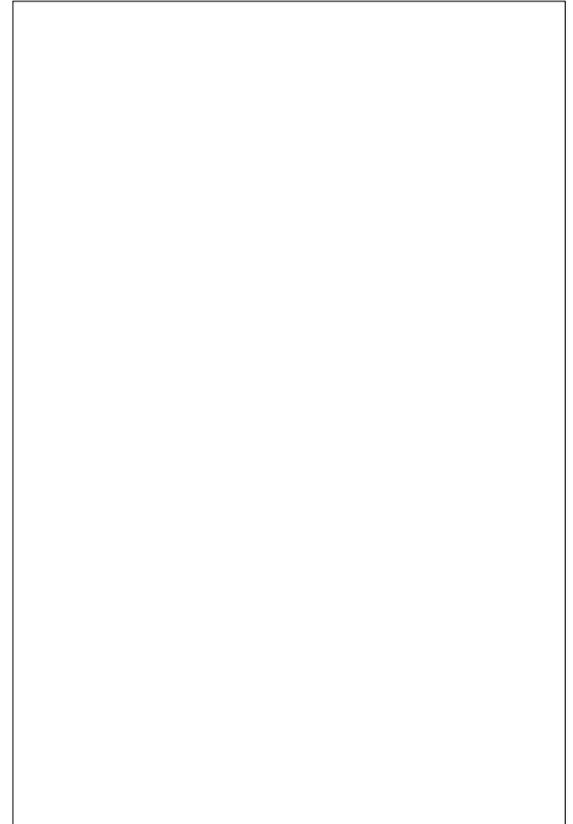

VSFxFIT35MS MAGNUM SERIES - XRIG™ - Basic Upright Extension kit +52.7" (134 cm.) - 3.15" x 3.15" x 8 Gauge (8 x 8 cm. x 4 mm.) Oversize Steel Tube

WEIGHT (Kg./Lbs)	L (cm.)	W (cm.)	H (cm.)
22 / 48	134	-	-

- Material: Powder coated steel - Color: Matte black
- Steel tubes size: 80x80x4 mm. - Base: 15x15x1 cm.
- Come either as a pair or as a pc, according to customers' needs.

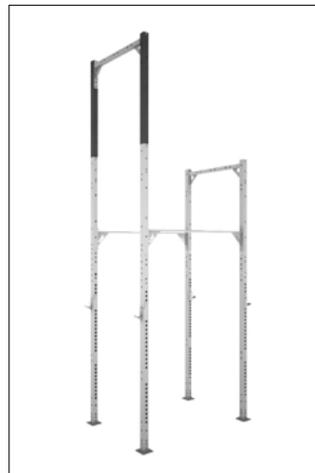

XRIG™ - PARTS AND OPTIONS

VSFXFIT34 XRIG™ - 16.6' Climbing Rope Tower Set

- XRIG™ - Basic Upright Extension kit + 52.7" (134 cm.) - x2PCs
- XRIG™ - 6' Junction Bar (168 cm.)
- Junction Bar Anchoring Tool for Rings and Rope c/carabiners - x2PCs

WEIGHT (Kg./Lbs)	L (cm.)	W (cm.)	H (cm.)
38 / 84	170	6	134

- Material: Powder coated steel - Color: Matte black
 - Steel tubes size: 60x60x3.5 mm.

⚠ Rope is not included.

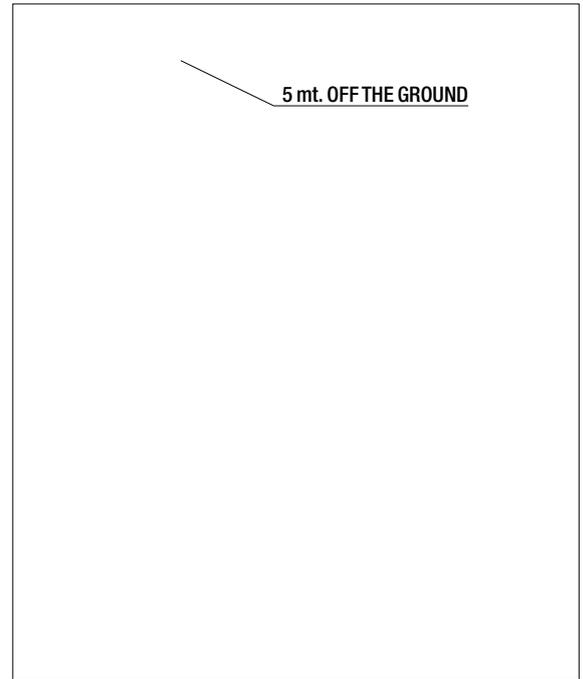

TM



VSFXFIT34MS MAGNUM SERIES - XRIG™ - 16.5' Climbing Rope Tower Kit (500 cm - 3.15" x 3.15" x 8 Gauge (8 x 8 cm. x 4 mm.) Oversize Steel Tube

- MAGNUM SERIES - XRIG™ - Basic Upright Extension kit +52.7" (134 cm.)
 - 3.15" x 3.15" x 8 Gauge (8 x 8 cm. x 4 mm.) Oversize Steel Tube - x1KIT
- XRIG™ - 6' Junction Bar (168 cm.) - x1PCs
- XRIG™ - Junction Bar Anchoring Tool for Rings and Rope w/carabiners and swivel - x2PCs

WEIGHT (Kg./Lbs)	L (cm.)	W (cm.)	H (cm.)
38 / 84	170	6	134

- Material: Powder coated steel - Color: Matte black
 - Steel tubes size: 60x60x3.5 mm.

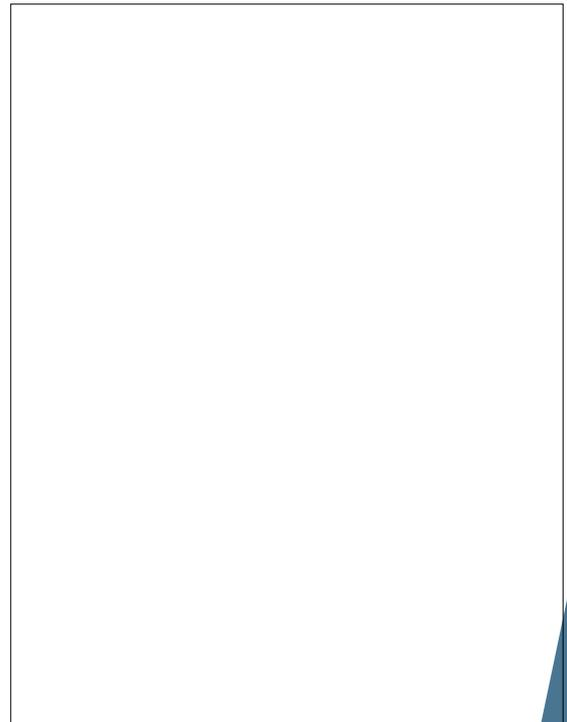
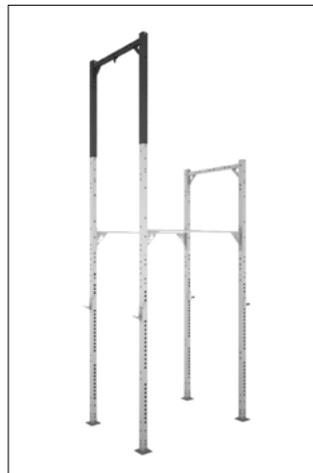

XRIG™ - PARTS AND OPTIONS

VSFXFIT24 XRIG™ - 4' English Ladder Short Bar

WEIGHT (Kg./Lbs)	L (cm.)	W (cm.)	H (cm.)
4 / 9	108	6	12

- Material: Powder coated steel - Color: Matte black
- Steel tubes size: 32x4 mm. round.



VSFXFIT14

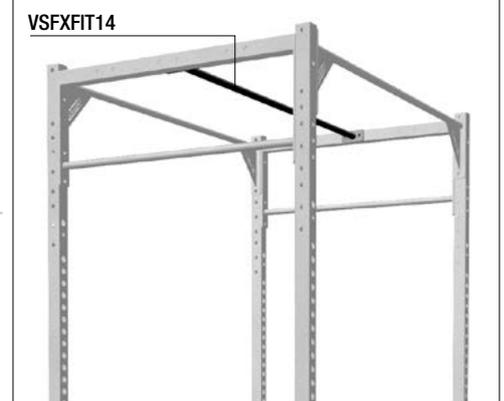

VSFXFIT14 XRIG™ - 6' English Ladder Bar

WEIGHT (Kg./Lbs)	L (cm.)	W (cm.)	H (cm.)
5 / 11	168	12	32

- Material: Powder coated steel - Color: Matte black
- Steel tubes size: 32x4 mm. round.



VSFXFIT06 XRIG™ - 6' Asymmetric English Ladder Bar

WEIGHT (Kg./Lbs)	L (cm.)	W (cm.)	H (cm.)
5 / 11	168	26	12

- Material: Powder coated steel - Color: Matte black
- Steel tubes size: 32x4 mm. round.



VSFXFIT63 XRIG™ - English Ladder Bar Shim (1 cm.)

WEIGHT (Kg./Lbs)	L (cm.)	W (cm.)	H (cm.)
1 / 2	12	6	1

- Material: Powder coated steel - Color: Matte black
- Steel tubes size: 32x4 mm round.
- M.S. (to be used with English Ladder Bars or Wing Ladder Bars mounted on Magnum Series Configs)

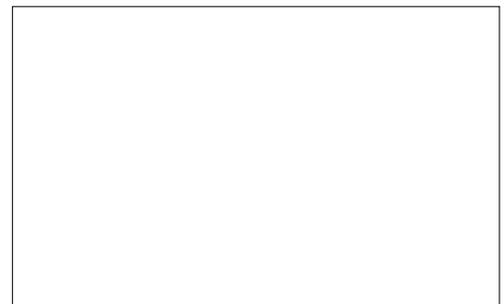

XRIG™ - PARTS AND OPTIONS

VSFXFIT15 XRIG™ - 6' English Ladder Side-Bar

WEIGHT (Kg./Lbs)	L (cm.)	W (cm.)	H (cm.)
9.5 / 21	168	6	31

- Material: Powder coated steel - Color: Matte black
- Steel tubes size: 32x4 mm round.



VSFXFIT31 XRIG™ - 6' English Ladder Side-Bar w/Speal Finishing

WEIGHT (Kg./Lbs)	L (cm.)	W (cm.)	H (cm.)
9.5 / 21	168	6	31

- Material: Powder coated steel - Color: Matte black - speal
- Steel tubes size: 32x4 mm round.

⚠ Speal steel bar may early get rusted. Frequently maintenance is duly required.

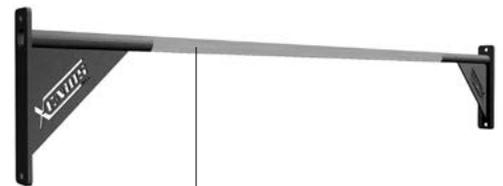

VSFXFIT33 XRIG™ - 4' Compact English Ladder Side Bar

WEIGHT (Kg./Lbs)	L (cm.)	W (cm.)	H (cm.)
6.5 / 14	108	6	31

- Material: Powder coated steel - Color: Matte black
- Steel tubes size: 32x4 mm round.



VSFXFIT13 XRIG™ - 4' Compact Pull-Up Bar

WEIGHT (Kg./Lbs)	L (cm.)	W (cm.)	H (cm.)
6.5 / 14	120	6	31

- Material: Powder coated steel - Color: Matte black
- Steel tubes size: 32x4 mm round.



XRIG™ - PARTS AND OPTIONS

VSFXFIT04 XRIG™ - 6' Basic Pull-Up frame

WEIGHT (Kg./Lbs)	L (cm.)	W (cm.)	H (cm.)
19 / 42	168	6	48

- Material: Powder coated steel - Color: Matte black
- Steel tubes size: 60x60x3.5 mm. + 32x4 mm round tubes.
- Pull-Up heights: 6'10"-7'6"-8'3" (only w/12' Uprights)

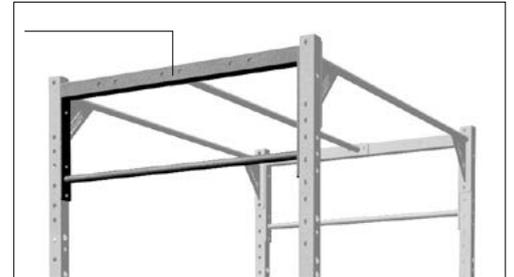

VSFXFIT05 XRIG™ - 4' Basic Pull-Up frame

WEIGHT (Kg./Lbs)	L (cm.)	W (cm.)	H (cm.)
13 / 29	108	6	48

- Material: Powder coated steel - Color: Matte black
- Steel tubes size: 60x60x3.5 mm. + 32x4 mm round tubes.
- Pull-Up heights: 6'10"-7'6"-8'3" (only w/12' Uprights)

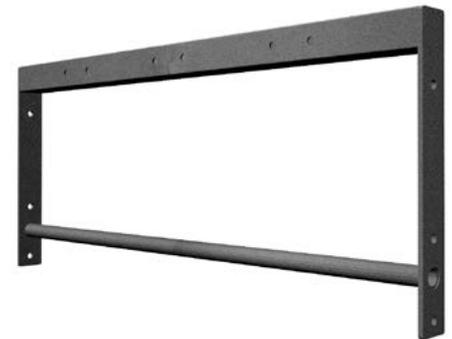

VSFXFIT05MS XRIG™ - 4' Basic Pull-Up frame (104 cm.) - M.S. (to be used with Magnum Series Rack)

WEIGHT (Kg./Lbs)	L (cm.)	W (cm.)	H (cm.)
13 / 29	104	6	48

- Material: Powder coated steel - Color: Matte black
- Steel tubes size: 60x60x3.5 mm. + 32x4 mm round tubes.
- Pull-Up heights: 6'10"-7'6"-8'3" (only w/12' Uprights)



VSFXFIT22 XRIG™ - 4' Pull-Up Double-Crossmember

WEIGHT (Kg./Lbs)	L (cm.)	W (cm.)	H (cm.)
9 / 20	108	6	38

- Material: Powder coated steel - Color: Matte black
- Steel tubes size: 32x4 mm round tubes.
- Pull-Up heights: 6'10"-7'6"-8'3" (only w/12' Uprights)

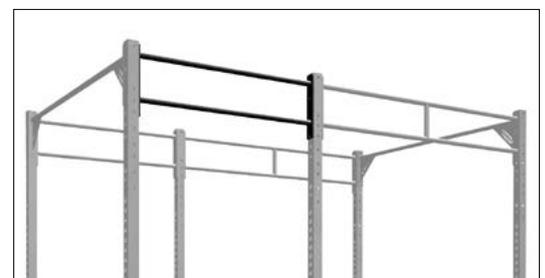

XRIG™ - PARTS AND OPTIONS

VSFXFIT23 XRIG™ - 6' Pull-Up Double-Crossmember

WEIGHT (Kg./Lbs)	L (cm.)	W (cm.)	H (cm.)
12 / 26.5	168	6	38

- Material: Powder coated steel - Color: Matte black
 - Steel tubes size: 32x4 mm round tubes.

- Pull-Up heights: 6'10"-7'6"-8'3" (only w/12' Uprights)

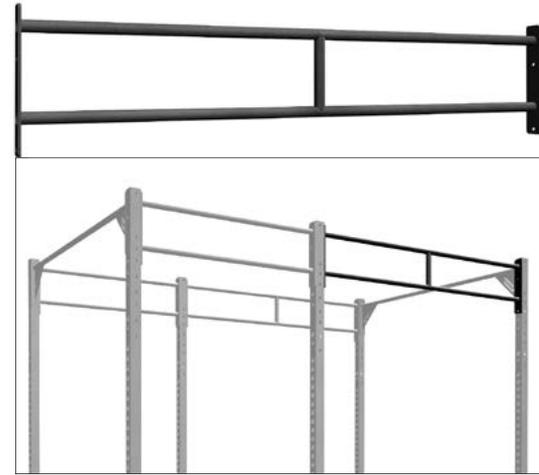

VSFXFIT28 XRIG™ - 4' Muscle-Up Bar

WEIGHT (Kg./Lbs)	L (cm.)	W (cm.)	H (cm.)
5 / 11	108	6	37

- Material: Powder coated steel - Color: Matte black
 - Steel tubes size: 32x4 mm round tubes.

- Pull-Up heights: 7'6"-8'-8'8"-9'5" (only w/12' Uprights)

- Available also with the smoother speal finishing, for perfect muscle-ups (VSFXFIT36)

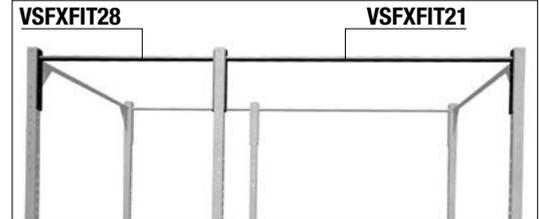

VSFXFIT21 XRIG™ - 6' Muscle-Up Bar

WEIGHT (Kg./Lbs)	L (cm.)	W (cm.)	H (cm.)
6.5 / 14	168	6	37

- Material: Powder coated steel - Color: Matte black
 - Steel tubes size: 32x4 mm round tubes.

- Pull-Up heights: 7'6"-8'-8'8"-9'5" (only w/12' Uprights)

- Available also with the smoother speal finishing, for perfect muscle-ups (VSFXFIT37)



VSFXFIT28MS XRIG™ - 4' Muscle-Up Bar (104 cm.) - M.S. (to be used with Magnum Series Rack)



WEIGHT (Kg./Lbs)	L (cm.)	W (cm.)	H (cm.)
5 / 11	104	6	37

- Material: Powder coated steel - Color: Matte black
 - Steel tubes size: 32x4 mm round tubes.

- Pull-Up heights: 7'6"-8'-8'8"-9'5" (only w/12' Uprights)

- Available also with the smoother speal finishing, for perfect muscle-ups (VSFXFIT36)



VSFXFIT36 XRIG™ - 4' Muscle-Up Bar w/Speal Finishing

WEIGHT (Kg./Lbs)	L (cm.)	W (cm.)	H (cm.)
5 / 11	108	6	37

- Material: Powder coated steel - Color: Matte black - speal
 - Steel tubes size: 32x4 mm round tubes.

- Pull-Up heights: 7'6"-8'-8'8"-9'5" (only w/12' Uprights)

⚠ Speal steel bar may early get rusted. Frequently maintenance is duly required.



VSFXFIT37 XRIG™ - 6' Muscle-Up Bar w/Speal Finishing

WEIGHT (Kg./Lbs)	L (cm.)	W (cm.)	H (cm.)
6.5 / 14	168	6	37

- Material: Powder coated steel - Color: Matte black - speal
 - Steel tubes size: 32x4 mm round tubes.

- Pull-Up heights: 7'6"-8'-8'8"-9'5" (only w/12' Uprights)

⚠ Speal steel bar may early get rusted. Frequently maintenance is duly required.



XRIG™ - PARTS AND OPTIONS

VSAXFIT52 XRIG™ - 12" Strongmen Pull-Up Globe w/carabiner and strap

WEIGHT (Kg./Lbs)	Dia. (cm.)
5.8 / 12.7	30

- Material: Powder coated steel - Color: Matte black - Carabiner and Strap included

12"

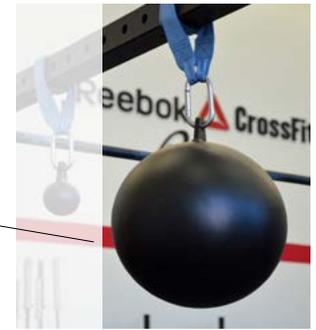

VSAXFIT53 XRIG™ - 5" Strongmen Pull-Up Marble

WEIGHT (Kg./Lbs)	Dia. (cm.)
1.2 / 2.6	13

- Material: Powder coated steel - Color: Matte black - Carabiner and Strap included

5"



VSAXFIT54 XRIG™ - 3" Strongmen Pull-Up Marble

WEIGHT (Kg./Lbs)	Dia. (cm.)
1.2 / 2.6	8

- Material: Powder coated steel - Color: Matte black - Carabiner and Strap included

3"

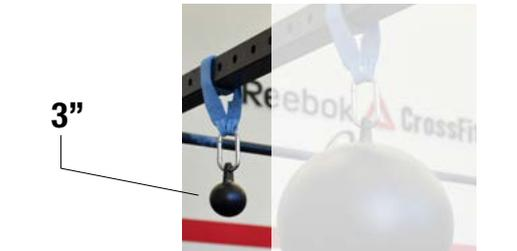

VSAXFIT55 XRIG™ - 3" Strongmen Pull-Up Marble w/carabiner and strap

WEIGHT (Kg./Lbs)	Dia. (cm.)
1.8 / 4	8

- Material: Powder coated steel - Color: Matte black - Carabiner and Strap included

3"



VSFXFIT08 XRIG™ - 6' Top Cross Member

WEIGHT (Kg./Lbs)	L (cm.)	W (cm.)	H (cm.)
18 / 40	168	6	37

- Material: Powder coated steel - Color: Matte black
- Steel tubes size: 32x4 mm round tubes.

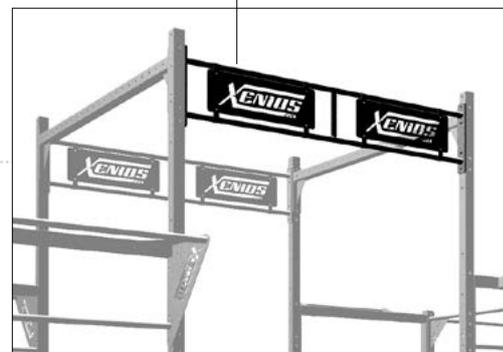
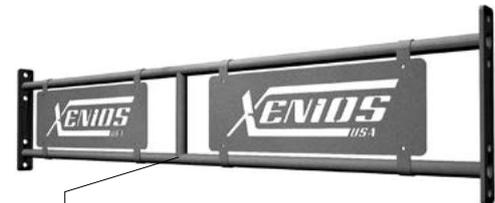

VSFXFIT10 XRIG™ - 4' Top Cross Member

WEIGHT (Kg./Lbs)	L (cm.)	W (cm.)	H (cm.)
18 / 40	108	6	37

- Material: Powder coated steel - Color: Matte black
- Steel tubes size: 32x4 mm round tubes.

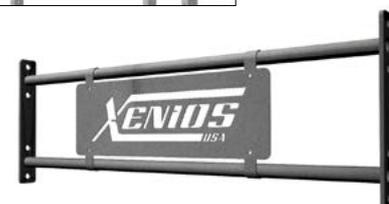

XRIG™ - PARTS AND OPTIONS

VSFXFIT09 XRIG™ - 6' Junction Bar

WEIGHT (Kg./Lbs)	L (cm.)	W (cm.)	H (cm.)
15 / 33	168	6	31

- Material: Powder coated steel - Color: Matte black
- Steel tubes size: 60x60x3.5 mm.

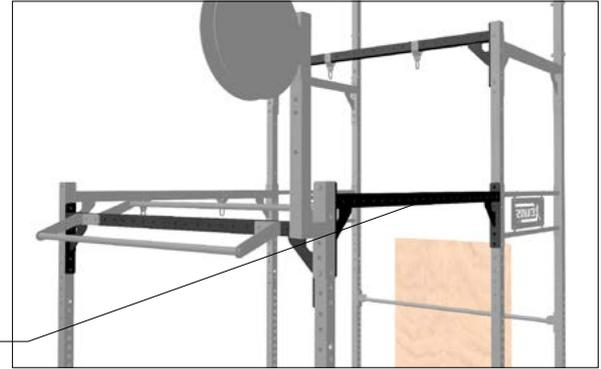

VSFXFIT26 XRIG™- 6' Junction Bar (168 cm.) - Chromed - to be used as a track for VSAXFIT18

WEIGHT (Kg./Lbs)	L (cm.)	W (cm.)	H (cm.)
15 / 33	168	6	31

- Material: Steel - Color: Chromed
- Steel tubes size: 60x60x3.5 mm.

- to be used as a track for VSAXFIT18

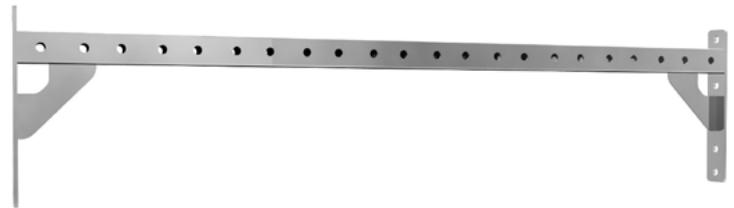

VSFXFIT11 XRIG™ - 4' Junction Bar

WEIGHT (Kg./Lbs)	L (cm.)	W (cm.)	H (cm.)
10 / 22	108	6	31

- Material: Powder coated steel - Color: Matte black
- Steel tubes size: 60x60x3.5 mm.



VSFXFIT11MS XRIG™- 4' Junction Bar (104 cm.) - M.S. (to be used with Magnum Series Rack)



WEIGHT (Kg./Lbs)	L (cm.)	W (cm.)	H (cm.)
10 / 22	104	6	31

- Material: Powder coated steel - Color: Matte black
- Steel tubes size: 60x60x3.5 mm.



VSAXFIT35 XRIG™ - 6' Offset Pull-Up Bar

WEIGHT (Kg./Lbs)	L (cm.)	W (cm.)	H (cm.)
6 / 13	135	23	10

- Material: Powder coated steel - Color: Matte black
- Steel tubes size: 32x4 mm. round.

- Pull-Up heights: 7'8.5"-8'2.4"-8'5.2"-8'11"-9'2"-9'8" (only w/12' Uprights)

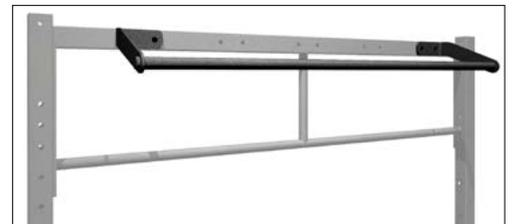

VSAXFIT36 XRIG™ - 4' Offset Pull-Up Bar

WEIGHT (Kg./Lbs)	L (cm.)	W (cm.)	H (cm.)
5 / 11	77	23	10

- Material: Powder coated steel - Color: Matte black
- Steel tubes size: 32x4 mm. round.

- Pull-Up heights: 7'8.5"-8'2.4"-8'5.2"-8'11"-9'2"-9'8" (only w/12' Uprights)

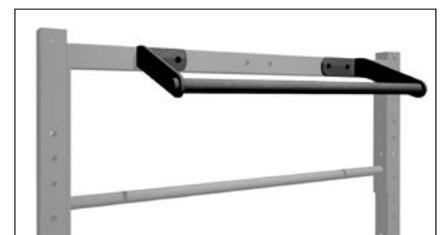

XRIG™ - PARTS AND OPTIONS

VSAXFIT01 XRIG™ - 6' Offset Pull-Up Frame

WEIGHT (Kg./Lbs)	L (cm.)	W (cm.)	H (cm.)
45 / 99	168	40	48

- Material: Powder coated steel - Color: Matte black
 - Steel tubes size: 60x60x3.5 mm. + 32x4 mm round tubes.

- Pull-Up heights: 7'9.9"-7'11.3"-7'6.6"-8'8.3"-8'3"-9'5" (only w/12' Uprights)



VSAXFIT06 XRIG™ - 4' Offset Pull-Up Frame

WEIGHT (Kg./Lbs)	L (cm.)	W (cm.)	H (cm.)
40 / 88	108	40	48

- Material: Powder coated steel - Color: Matte black
 - Steel tubes size: 60x60x3.5 mm. + 32x4 mm round tubes.

- Pull-Up heights: 7'9.9"-7'11.3"-7'6.6"-8'8.3"-8'3"-9'5" (only w/12' Uprights)



VSAXFIT06MS XRIG™ - 4' Offset Pull-Up Frame (104 cm.) - M.S. (to be used with Magnum Series Rack)



WEIGHT (Kg./Lbs)	L (cm.)	W (cm.)	H (cm.)
38 / 83	104	40	48

- Material: Powder coated steel - Color: Matte black
 - Steel tubes size: 60x60x3.5 mm. + 32x4 mm round tubes.

- Pull-Up heights: 7'9.9"-7'11.3"-7'6.6"-8'8.3"-8'3"-9'5" (only w/12' Uprights)



VSAXFIT02 XRIG™ - 6' Offset Wing Ladder - 4 steps

WEIGHT (Kg./Lbs)	L (cm.)	W (cm.)	H (cm.)
46 / 101.5	136	180	120

- Material: Powder coated steel - Color: Matte black
 - Steel tubes size: 60x60x3.5 mm. + 32x4 mm round tubes.

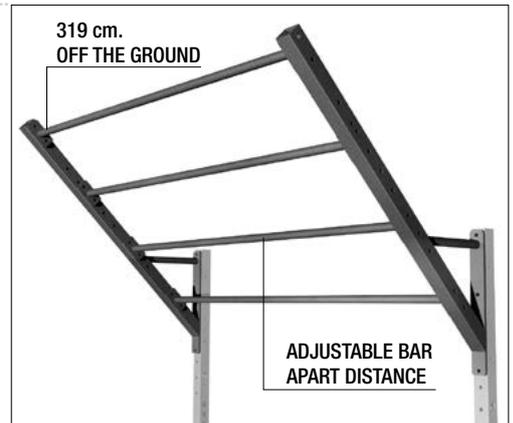

VSAXFIT07 XRIG™ - 4' Offset Wing Ladder - 4 steps

WEIGHT (Kg./Lbs)	L (cm.)	W (cm.)	H (cm.)
29.5 / 65	136	120	120

- Material: Powder coated steel - Color: Matte black
 - Steel tubes size: 60x60x3.5 mm. + 32x4 mm round tubes.



XRIG™ - PARTS AND OPTIONS

VSFXFIT25 XRIG™ - Short Corner Bar

WEIGHT (Kg./Lbs)	L (cm.)	W (cm.)	H (cm.)
5 / 11	112	10	27

- Material: Powder coated steel - Color: Matte black
- Steel tubes size: 32x4 mm round tubes.



VSFXFIT27 XRIG™ - Long Corner Bar (175 cm.)

WEIGHT (Kg./Lbs)	L (cm.)	W (cm.)	H (cm.)
8 / 18	175.5	10	27

- Material: Powder coated steel - Color: Matte black
- Steel tubes size: 32x4 mm round tubes.

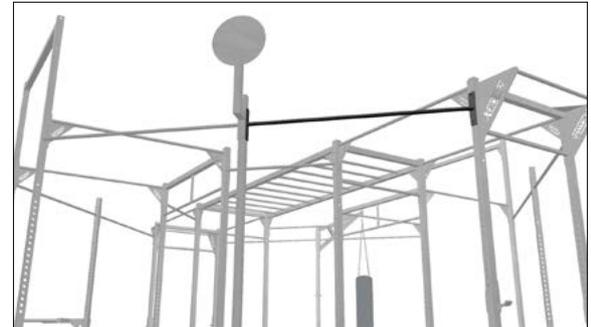

VSFXFIT29 XRIG™ - 11' Junction Bar

WEIGHT (Kg./Lbs)	L (cm.)	W (cm.)	H (cm.)
20 / 44	330	6	31

- Material: Powder coated steel - Color: Matte black
- Steel tubes size: 60x60x3.5 mm.

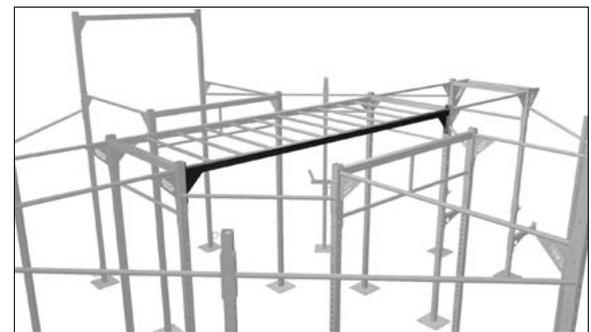

VSFXFIT30 XRIG™ - 4' Ladder Bar

WEIGHT (Kg./Lbs)	L (cm.)	W (cm.)	H (cm.)
4 / 9	108	6	12

- Material: Powder coated steel - Color: Matte black
- Steel tubes size: 32x4 mm round tubes.



XRIG™ - PARTS AND OPTIONS

VSFXFIT12 XRIG™- 6' Base Crossmember

WEIGHT (Kg./Lbs)	L (cm.)	W (cm.)	THICK. (cm.)
50 / 110	208	34	1

- Material: Powder coated steel - Color: Matte black

⚠ VSFXFIT03/16 are not included.

VSFXFIT38 XRIG™ - 4' Base Crossmember

WEIGHT (Kg./Lbs)	L (cm.)	W (cm.)	THICK. (cm.)
40 / 88	148	34	1

- Material: Powder coated steel - Color: Matte black

⚠ VSFXFIT03/16 are not included.

VSFXFIT40 XRIG™ - 3' Base Crossmember (90 cm.)

WEIGHT (Kg./Lbs)	L (cm.)	W (cm.)	THICK. (cm.)
30 / 66	90	34	1

- Material: Powder coated steel - Color: Matte black

VSFXFIT41 XRIG™ - Paraller Bars 6' Base Cross Member (180 cm.)

WEIGHT (Kg./Lbs)	L (cm.)	W (cm.)	THICK. (cm.)
45 / 99	154	34	1

- Material: Powder coated steel - Color: Matte black

VSAXFIT03 XRIG™ - Dip Horns

WEIGHT (Kg./Lbs)	L (cm.)	W (cm.)	H (cm.)
9.5 / 21	70	61	29

- Material: Powder coated steel - Color: Matte black

VSAXFIT03MS MAGNUM SERIES - XRIG™ - Dip Horns - 8 Gauge (4 mm. steel thickness)

WEIGHT (Kg./Lbs)	L (cm.)	W (cm.)	H (cm.)
9.5 / 21	70	61	29

- Material: Powder coated steel - Color: Matte black

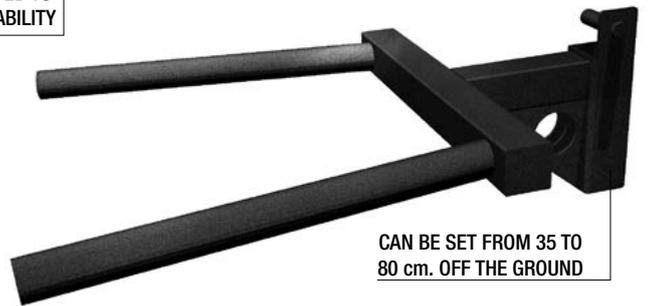
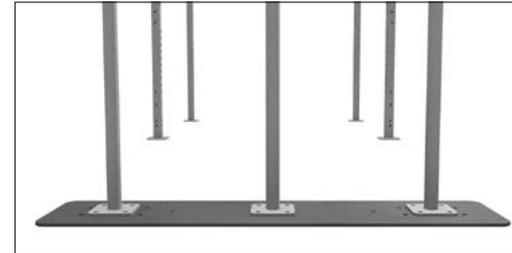
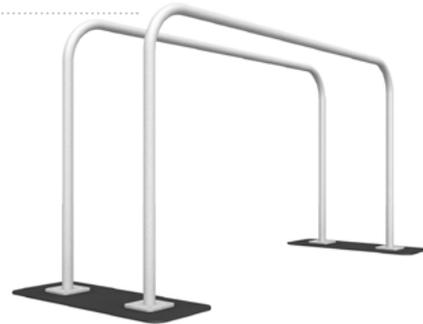
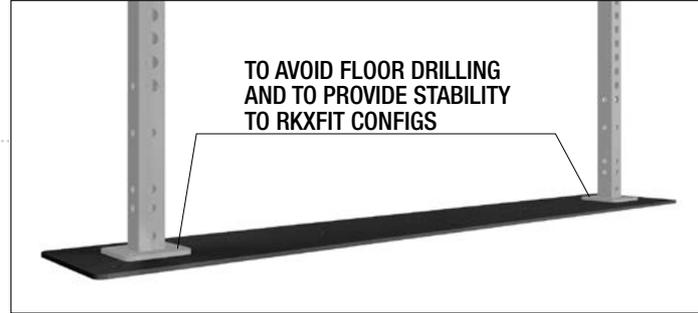

XRIG™ - PARTS AND OPTIONS

XRIG™ - PARTS AND OPTIONS

VSAXFIT04 XRIG™ - Step-Up Platform

WEIGHT (Kg./Lbs)	L (cm.)	W (cm.)	H (cm.)
35 / 77	82	50	29

- Material: Powder coated steel - Color: Matte black

 KNOB-BOLT EQUIPPED TO PROVIDE MORE STABILITY

ANTI-SLIP EPDM PAD



CAN BE SET FROM 35 TO 80 cm. OFF THE GROUND

VSAXFIT15 XRIG™ - Core Trainer Fulcrum

WEIGHT (Kg./Lbs)	L (cm.)	W (cm.)	H (cm.)
2.2 / 4.8	12	6	15

- Material: Powder coated steel - Color: Matte black

⚠ Core Trainer is not included.

⚠ Sold as a pair.



VSAXFIT08 XRIG™ - Bar J-Rack

WEIGHT (Kg./Lbs)	L (cm.)	W (cm.)	H (cm.)
4.8 / 10.5	17	9	22

- Material: Powder coated steel - Color: Matte black - Max Load: 500 kg.



NYLON PADS



VSAXFIT08MS MAGNUM SERIES - XRIG™ - Bar J-Rack - 8 Gauge (4 mm. steel thickness)

WEIGHT (Kg./Lbs)	L (cm.)	W (cm.)	H (cm.)
4.8 / 10.5	17	9	22

- Material: Powder coated steel - Color: Matte black - Max Load: 500 kg.



VSAXFIT09 XRIG™ - Safety Spotter Arm

WEIGHT (Kg./Lbs)	L (cm.)	W (cm.)	H (cm.)
28 / 62	66	9	29

- Material: Powder coated steel - Color: Matte black - Max Load: 500 kg.



NYLON PADS



VSAXFIT09MS MAGNUM SERIES - XRIG™ - Safety Spotter Arm - 3.15" x 3.15" x 8 Gauge (8 x 8 cm. x 4 mm.) Oversize Steel Tube

WEIGHT (Kg./Lbs)	L (cm.)	W (cm.)	H (cm.)
20 / 44	66	9	29

- Material: Powder coated steel - Color: Matte black - Max Load: 500 kg.



XRIG™ - PARTS AND OPTIONS

VSAXFIT10 XRIG™ - Plates Storage Sleeve

WEIGHT (Kg./Lbs)	L (cm.)	W (cm.)	H (cm.)
4 / 9	43	6.5	14

- Material: Powder coated steel - Color: Matte black - Max Load: 300 kg.
 - Steel tubes size: 60x60x3.5 mm.

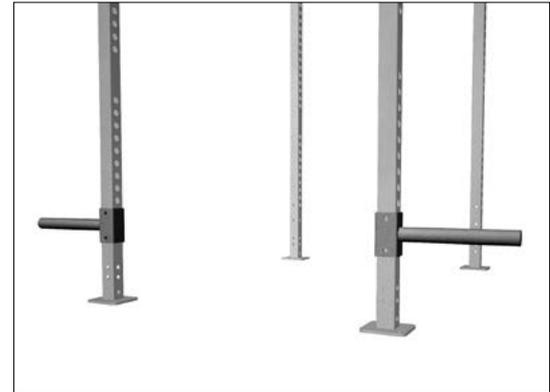

VSAXFIT10MS MAGNUM SERIES - XRIG™ - Plates Storage Sleeve - 8 Gauge (4 mm. steel thickness)

WEIGHT (Kg./Lbs)	L (cm.)	W (cm.)	H (cm.)
10 / 22	43	9	14

- Material: Powder coated steel - Color: Matte black - Max Load: 300 kg.
 - Steel tubes size: 80x80x4 mm.

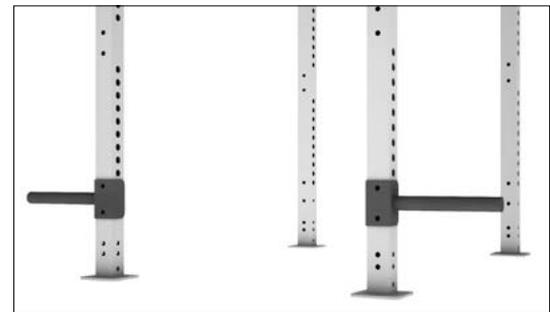

VSAXFIT30 XRIG™ - Plates Sleeve

WEIGHT (Kg./Lbs)	L (cm.)	DIA. (mm.)	H (cm.)
1.7 / 3.7	44	48	-

- Material: Powder coated steel - Color: Matte black - Max Load: 300 kg.
 - Steel tubes size: 60x60x3.5 mm.

⚠ VSFXFIT03/16 are not included.

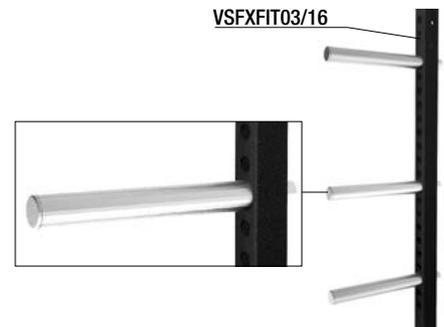

VSAXFIT30MS XRIG™ - Plates Sleeve - M.S. (to be used with Magnum Series Uprights)

WEIGHT (Kg./Lbs)	L (cm.)	DIA. (mm.)	H (cm.)
1.7 / 3.7	44	48	-

- Material: Powder coated steel - Color: Matte black - Max Load: 300 kg.
 - Steel tubes size: 80x80x4 mm.

⚠ VSFXFIT03/16 are not included.

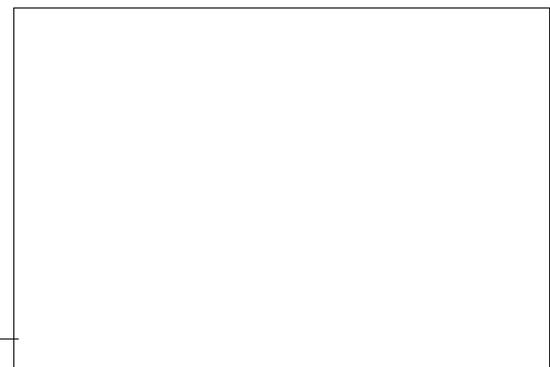

XRIG™ - PARTS AND OPTIONS

VSAXFIT29 XRIG™ - Safety Strap Anchoring Tool - (to be used with XRIG™ Power Lifting Cage configs)

WEIGHT (Kg./Lbs)	L (cm.)	W (cm.)	H (cm.)
2 / 4.4	11	9	12

- Material: Powder coated steel - Color: Matte black

⚠ VSAXFIT31 is not included.



VSAXFIT31 XRIG™ - 2"x55" (5x105 cm.) Nylon Safety Strap w/HD Carabiner (Max.Load 1200 Kg.)- (to be used with XRIG™ Power Lifting Cage configs)

WEIGHT (Kg./Lbs)	L (cm.)	W (cm.)	H (cm.)
0.5 / 1.1	110	5	-

- Material: Nylon - Color: Black - Max Load: 180 kg.

VSAXFIT29MS XMAGNUM SERIES - XRIG™ - Safety Strap Anchoring Tool - 8 Gauge (4 mm. steel thickness) - (to be used with XRIG™ Power Lifting Cage Magnum Series)

WEIGHT (Kg./Lbs)	L (cm.)	W (cm.)	H (cm.)
2 / 4.4	11	9	12

- Material: Powder coated steel - Color: Matte black

⚠ VSAXFIT31 is not included.

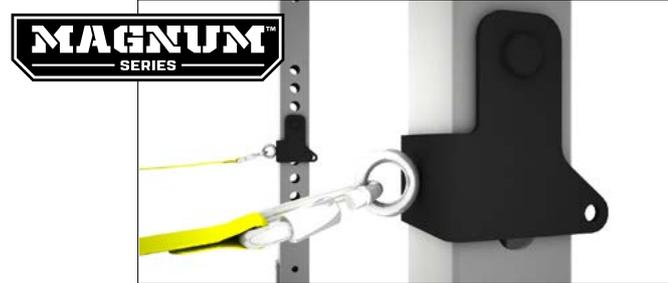

VSAXFIT11 XRIG™ - Power Band Pegs Arm

WEIGHT (Kg./Lbs)	L (cm.)	W (cm.)	H (cm.)
12 / 26.5	72	22	14

- Material: Powder coated steel - Color: Matte black



VSAXFIT11MS MAGNUM SERIES - XRIG™ - Power Band Pegs Arm - 8 Gauge - 3.15" x 3.15" x 8 Gauge (8 x 8 cm. x 4 mm.) Oversize Steel Tube

WEIGHT (Kg./Lbs)	L (cm.)	W (cm.)	H (cm.)
12 / 26.5	72	22	14

- Material: Powder coated steel - Color: Matte black

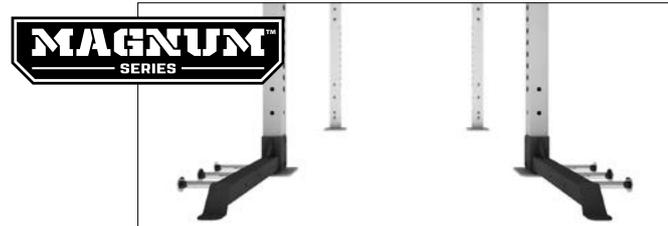

VSAXFIT20 XRIG™ - Carabiner Anchoring Tool

WEIGHT (Kg./Lbs)	L (cm.)	W (cm.)	H (cm.)
0.4 / 0.9	8	5	14

- Material: Powder coated steel - Color: Matte black

SAFETY STEEL PIN
W/ LOCKING SPRING

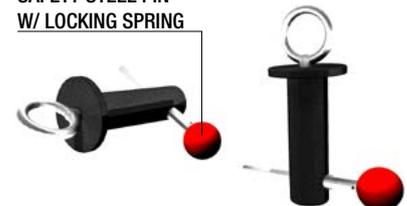

VSAXFIT17 XRIG™ - Training Rope Anchoring Ring

WEIGHT (Kg./Lbs)	L (cm.)	W (cm.)	H (cm.)
0.4 / 0.9	13	6	20

- Material: Powder coated steel - Color: Matte black



XRIG™ - PARTS AND OPTIONS

VSAXFIT21 XRIG™ - Vertical Power Band Hook

WEIGHT (Kg./Lbs)	L (cm.)	W (cm.)	H (cm.)
2.5 / 5.5	15	9	7

- Material: Powder coated steel - Color: Matte black



VSAXFIT19 XRIG™ - Horizontal Power Band Hook

WEIGHT (Kg./Lbs)	L (cm.)	W (cm.)	H (cm.)
2.5 / 5.5	11	8.5	9

- Material: Powder coated steel - Color: Matte black



VSAXFIT32 XRIG™ - Junction Bar Anchoring Tool for Rings and Rope w/carabiners and swivel

WEIGHT (Kg./Lbs)	L (cm.)	W (cm.)	H (cm.)
5.2 / 11.5	10	16	15

- Material: Powder coated steel - Color: Matte black

⚠️ VSFXFIT09 and VSCBRP01 are not included.

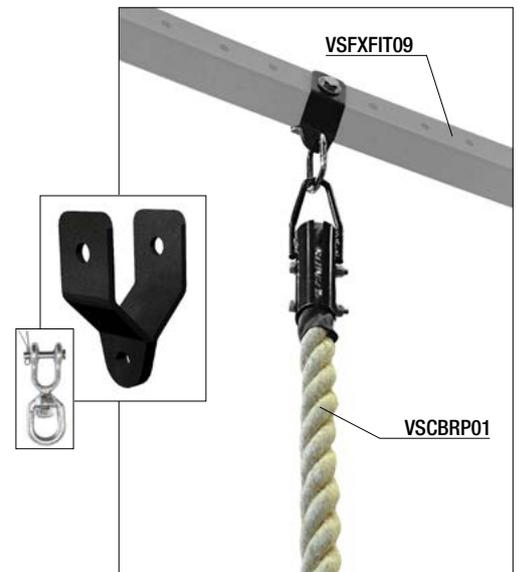

VSAXFIT14 XRIG™ - Front-grip Pull-up Handle

WEIGHT (Kg./Lbs)	L (cm.)	W (cm.)	H (cm.)
2 / 4.4	25	6	41

- Material: Powder coated steel - Color: Matte black



XRIG™ - PARTS AND OPTIONS

VSAXFIT13 XRIG™ - Wall Ball Target

WEIGHT (Kg./Lbs)	L (cm.)	W (cm.)	H (cm.)
8 / 17.6	100	45	16.5

- Material: Powder coated steel - Color: Matte black
- Steel tubes size: 60x60x3.5 mm.



VSAXFIT43 XRIG™ - Offset Double Wall Ball Target

WEIGHT (Kg./Lbs)	L (cm.)	W (cm.)	H (cm.)
25 / 55	54	6	85

- Material: Powder coated steel - Color: Matte black
- Steel tubes size: 60x60x3.5 mm.



VSAXFIT44 XRIG™ - HandStand Board Kit

- XRIG™ - HandStand Board Kit - Hardware (6' RIG or 4' RACK mounting) - x1KIT
- XRIG™ - HandStand Wood Board (250 cm. x 118 cm. x 1.8 cm.) - x1PCs

WEIGHT (Kg./Lbs)	L (cm.)	H (cm.)	THICK. (cm.)
20 / 44	100	210	1.8

- Material: Plywood - Color: Wood
- Equipped w/hardware for 6' RIG and 4' RACK



XRIG™ - PARTS AND OPTIONS

VSAXFIT57 XRIG™ - Offset Calisthenics Parallel Bars Attachment - Corner Mounted

WEIGHT (Kg./Lbs)	L (cm.)	W (cm.)	H (cm.)
35 / 77	230	56	125

- Material: Powder coated steel - Color: Matte black
- Steel tubes size: 48x48x3.5 mm.



VSAXFIT58 XRIG™ - Offset Calisthenics Parallel Bars Attachment - Rack Front mounted

WEIGHT (Kg./Lbs)	L (cm.)	W (cm.)	H (cm.)
35 / 77	230	120	125

- Material: Powder coated steel - Color: Matte black
- Steel tubes size: 48x48x3.5 mm.



VSAXFIT59 XRIG™ - Offset Calisthenics Parallel Bars Attachment - Rig Front mounted - Double Dip

WEIGHT (Kg./Lbs)	L (cm.)	W (cm.)	H (cm.)
70 / 154	230	180	125

- Material: Powder coated steel - Color: Matte black
- Steel tubes size: 48x48x3.5 mm.



VSAXFIT26 XRIG™ - 39" Short Pull-Up Bar

WEIGHT (Kg./Lbs)	L (cm.)	W (cm.)	H (cm.)
6 / 13	100	6	31

- Material: Powder coated steel - Color: Matte black
- Steel tubes size: 32x4 mm round tubes.

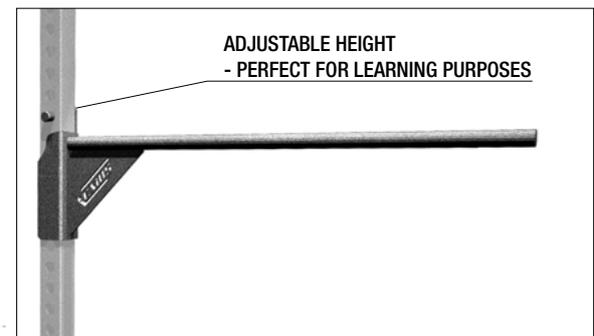

XRIG™ - PARTS AND OPTIONS

VSAXFIT47 XRIG™ - 6' Learning Pull-Up Bar

WEIGHT (Kg./Lbs)	L (cm.)	W (cm.)	H (cm.)
8 / 17.6	166	6	15

- Material: Powder coated steel - Color: Matte black
- Steel tubes size: 32x4 mm round tubes.



VSAXFIT49 XRIG™ - 4' Vertical Ladder Kit (7 steps)

WEIGHT (Kg./Lbs)	L (cm.)	W (cm.)	H (cm.)
35 / 77	108	-	-

- Material: Powder coated steel - Color: Matte black
- Steel tubes size: 32x4 mm round tubes.



VSAXFIT64 XRIG™ - 6' Vertical Ladder Kit (168 cm.)

WEIGHT (Kg./Lbs)	L (cm.)	W (cm.)	H (cm.)
35 / 77	168	-	-

- Material: Powder coated steel - Color: Matte black
- Steel tubes size: 32x4 mm round tubes.



VSAXFIT60 XRIG™ - Bleech Wood Swedish Ladder Rig-Mounting Kit (to be used with PSSLW01)

WEIGHT (Kg./Lbs)	L (cm.)	W (cm.)	H (cm.)
12 / 26	178	18.5	17.5

- Material: Powder coated steel - Color: Matte black
- Steel tubes size: 60x60x3.5 mm.



XRIG™ - PARTS AND OPTIONS

VSAXFIT61 XRIG™ - Bleech Wood Swedish Ladder Rack-Mounting Kit (to be used with PSSLW02)

WEIGHT (Kg./Lbs)	L (cm.)	W (cm.)	H (cm.)
8 / 16	108	19	17.5

- Material: Powder coated steel - Color: Matte black
- Steel tubes size: 60x60x3 mm.



VSAXFIT16 XRIG™ - Boxing Bag Arm

WEIGHT (Kg./Lbs)	L (cm.)	W (cm.)	H (cm.)
15 / 33	100	10	92

- Material: Powder coated steel - Color: Matte black
- Steel tubes size: 60x60x3.5 mm.

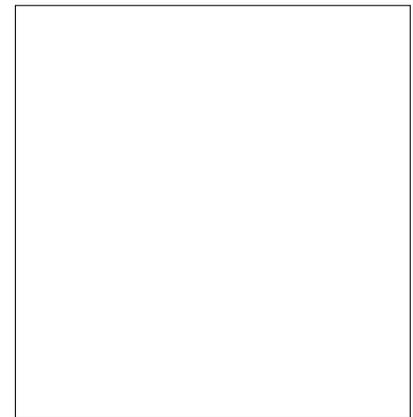

VSAXFIT33 XRIG™ - Side Offset Support

WEIGHT (Kg./Lbs)	L (cm.)	W (cm.)	H (cm.)
10 / 22	81.5	15	120

- Material: Powder coated steel - Color: Matte black
- Steel tubes size: 60x60x3 mm. - Special for outdoor un-even ground

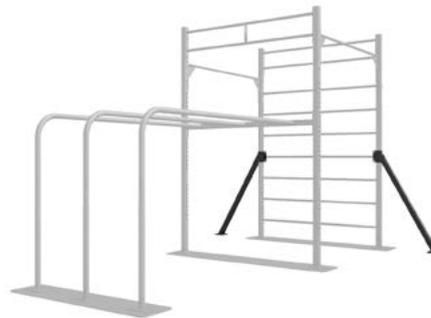

PRE-DRILLED
TO BE SCREWED-IN
TO CONCRETE

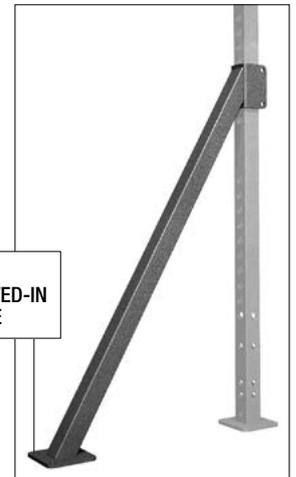

VSAXFIT34 XRIG™ - Offset Gym Rings Station

WEIGHT (Kg./Lbs)	L (cm.)	W (cm.)	H (cm.)
7 / 15.5	110	6	31

- Material: Powder coated steel - Color: Matte black
- Steel tubes size: 60x60x3.5 mm.



XRIG™ - PARTS AND OPTIONS

VSAXFIT24 XRIG™ - Wing Ladder Reverse Connection - (to be used to build the RKXFIT10 config)

WEIGHT (Kg./Lbs)	L (cm.)	W (cm.)	H (cm.)
6 / 13	23	6.5	34

- Material: Powder coated steel - Color: Matte black
- To be used to build the RKXFIT10 config

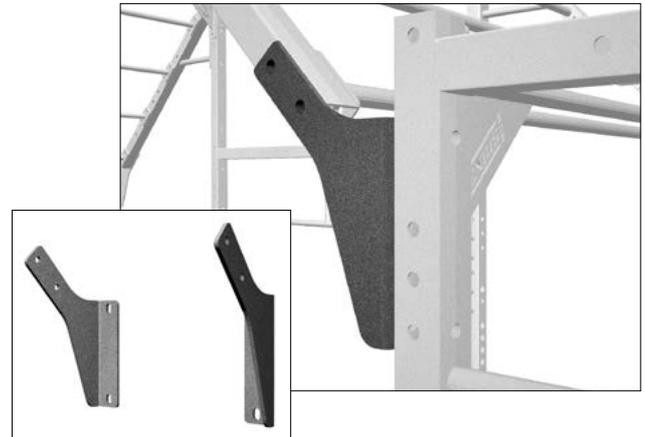

VSAXFIT18 XRIG™ - 360° Revolving Pull-Up Handle

WEIGHT (Kg./Lbs)	L (cm.)	W (cm.)	H (cm.)
4 / 8.8	15	7	25

- Material: Powder coated steel - Color: Matte black
- To be used with VSFXFIT26

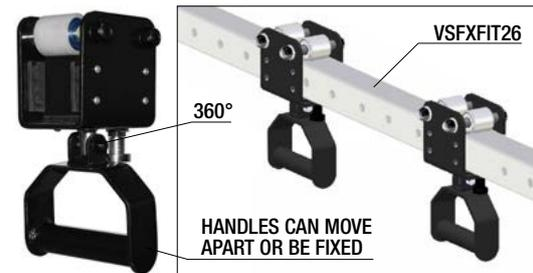

VSAXFIT25 XRIG™ - 6' x 12' Cargo Net

WEIGHT (Kg./Lbs)	L (cm.)	W (cm.)	H (cm.)
30 / 66	360	210	-

- Material: Nylon - Color: Matte black
- Rope diameter: 18 mm.

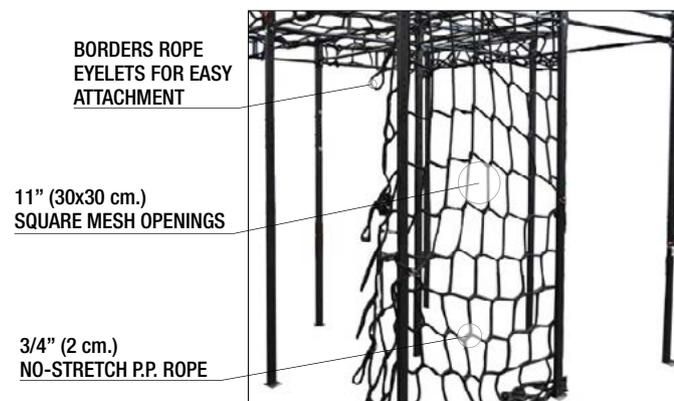

XRIG™ - PARTS AND OPTIONS

VSAXFIT45 XRIG™ - 6' Xenios USA Laser Cut Logo Panel

WEIGHT (Kg./Lbs)	L (cm.)	W (cm.)	THICK. (cm.)
20 / 44	168	50	2

- Material: Powder coated steel - Color: Matte black

VSAXFIT46 XRIG™ - Athlete Lane Marker Dish (w/magnet)

VSAXFIT63 XRIG™ - 30" Xenios USA Vertical Laser Cut Logo Panel (73 cm.)

WEIGHT (Kg./Lbs)	L (cm.)	W (cm.)	H (cm.)
3 / 6	30	6	73

- Material: Powder coated steel - Color: Matte black

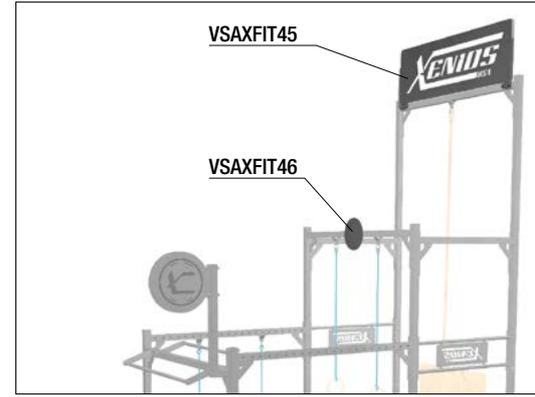
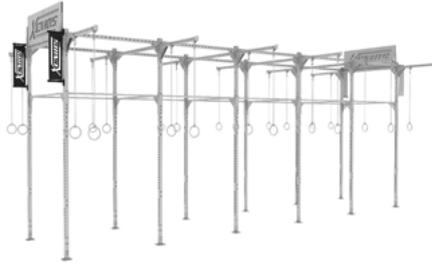

XRIG™ - PARTS AND OPTIONS

VSAXFIT62 XRIG™ - Safety Dome for Uprights (to be used with VSFXFIT03,06,41)

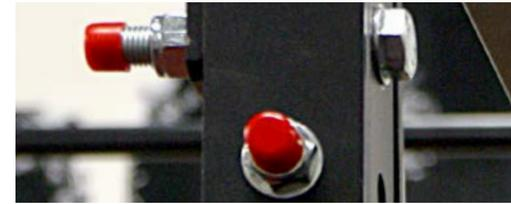

VSAXFIT27 XRIG™ - Concrete screwing set

⚠ Special concrete screwing bolts feature 11 cm. length. They are suitable for concrete floorings. Ask for custom solutions if needed.

VSAXFIT28 XRIG™ - Wall Mounting set

⚠ Special wall mounting bolts feature 8.7 cm. length. They are suitable for concrete or solid bricks walls. Ask for custom solutions if needed.

VSAXFIT37 XRIG™ - Wall Mounting set

- 2 steel bolts w/special expanders for empty bricks

⚠ Special wall mounting bolts feature 8.7 cm. length. They are suitable for concrete or solid bricks walls. Ask for custom solutions if needed.

VSAXFIT38 XRIG™ - Anti-theft Nut

- Special for outdoor uses

VSAXFIT50 XRIG™ - 9' and 12' Basic Upright Zinc Plated Steel Shim - 0,2 cm.

VSAXFIT51 XRIG™ - 9' and 12' Basic Upright Zinc Plated Steel Shim - 0,5 cm.

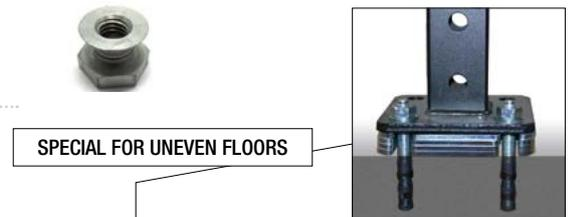
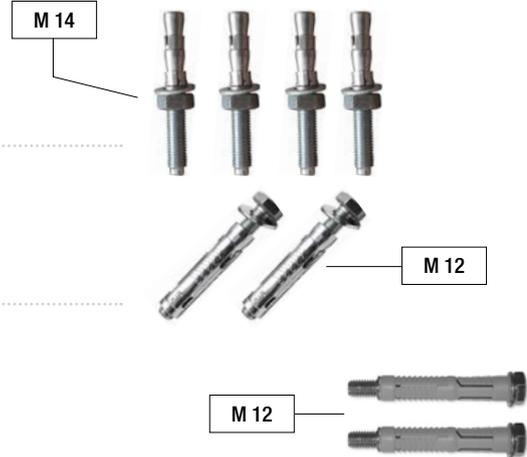

RE-HAB AND MOBILITY

RE-HAB AND MOBILITY

VSAXFIT48K

Crossover Workout Kit

- XRIG™ and RACK option - Carabiner Anchoring Tool x2PCs
- 24" Strap anchor w/ring - (60 cm.) x2PCs
- Crossover Workout - 3 Lbs x 47" XLight Elastic Tube w/handle x2PCs
- Length: 120 cm. - Resistance: 1.5 Kg.
- Crossover Workout - 5 Lbs x 47" Light Elastic Tube w/handle x2PCs
- Length: 120 cm. - Resistance: 2.5 Kg.
- Crossover Workout - 7 Lbs x 47" Medium Elastic Tube w/handle x2PCs
- Length: 120 cm. - Resistance: 3,5 Kg.
- Crossoverworkout Kit Nylon Carry Bag x1PC



XSMUEST11

Crossover Workout - 3 Lbs x 47" XLight Elastic Tube

- Length: 100 cm. - Resistance: 1.5 Kg.



XSMUEST12

Crossover Workout - 5 Lbs x 47" Light Elastic Tube

- Length: 100 cm. - Resistance: 2.5 Kg.



XSMUEST13

Crossover Workout - 7 Lbs x 47" Medium Elastic Tube

- Length: 100 cm. - Resistance: 3.5 Kg.



XSMUEST14

Crossover Workout - 12 Lbs x 47" Heavy Elastic Tube w/handle

- Length: 115 cm. - Resistance: 5.5 Kg.



CROSSOVER
WORKOUT™



XRIG™ - PARTS AND OPTIONS

VSAXFIT22 XRIG™ - Back-Bone-Like Boxing Bag

WEIGHT (Kg./Lbs)	L (cm.)	W (cm.)	H (cm.)
30 / 110	-	-	100

- Material: Leather - Color: Black
- Diameter: 30 cm. - Carbon-look "BTEX" Fabric - 2IM antfire class certified
- Chains, Swivel hook and Carabiner included

SPECIAL
BACK-BONE-LIKE
INNER CONSTRUCTION

CARBON LOOK



VSAXFIT23/23



VSAXFIT23 XRIG™ - Back-Bone-Like Boxing Bag

WEIGHT (Kg./Lbs)	L (cm.)	W (cm.)	H (cm.)
50 / 110	-	-	100

- Material: Leather - Color: Black
- Diameter: 30 cm. - Carbon-look "BTEX" Fabric - 2IM antfire class certified
- Chains, Swivel hook and Carabiner included

XSXFITMAT01 Crash Mat - 6.6' x 3.3' x 2" with handles

WEIGHT (Kg./Lbs)	L (cm.)	W (cm.)	H (cm.)
2 / 4.5	200	100	5

- Anti-slip bottom side - Density 80° - Sanitized "BTEX" Coated - Color: Blue
- Can fit XFit RIG and RACK



XSXFITMAT02 Crash Mat - 6.6' x 3.3' x 8" with handles

WEIGHT (Kg./Lbs)	L (cm.)	W (cm.)	H (cm.)
10 / 22	200	100	20

- Anti-slip bottom side - Density 16° - Sanitized "BTEX" Coated - Color: Blue
- Can fit XFit RIG and RACK



XSXFITMAT03 Crash Mat - 6.6' x 3.3' x 19.5" with handles

WEIGHT (Kg./Lbs)	L (cm.)	W (cm.)	H (cm.)
20 / 44	200	100	50

- Anti-slip bottom side - Density 16° - Sanitized "BTEX" Coated - Color: Blue
- Can fit XFit RIG and RACK





DPK
REACTION TIME

HARD WORK
IS NOW FUN
HARD FUN

Reebok

XENIOS

162

XENIOS
USA
162

162

XENIOS

XENIOS
USA

#TO BE XENIOS USA

XENIOS USA® T-SHIRT

**XENIOS USA® T-SHIRT
COACH**

**XENIOS USA® T-SHIRT
ATHLETE**

XENIOS USA® HOODIE



XENIOS USA® BRACELETS



#TO BE XENIOS USA

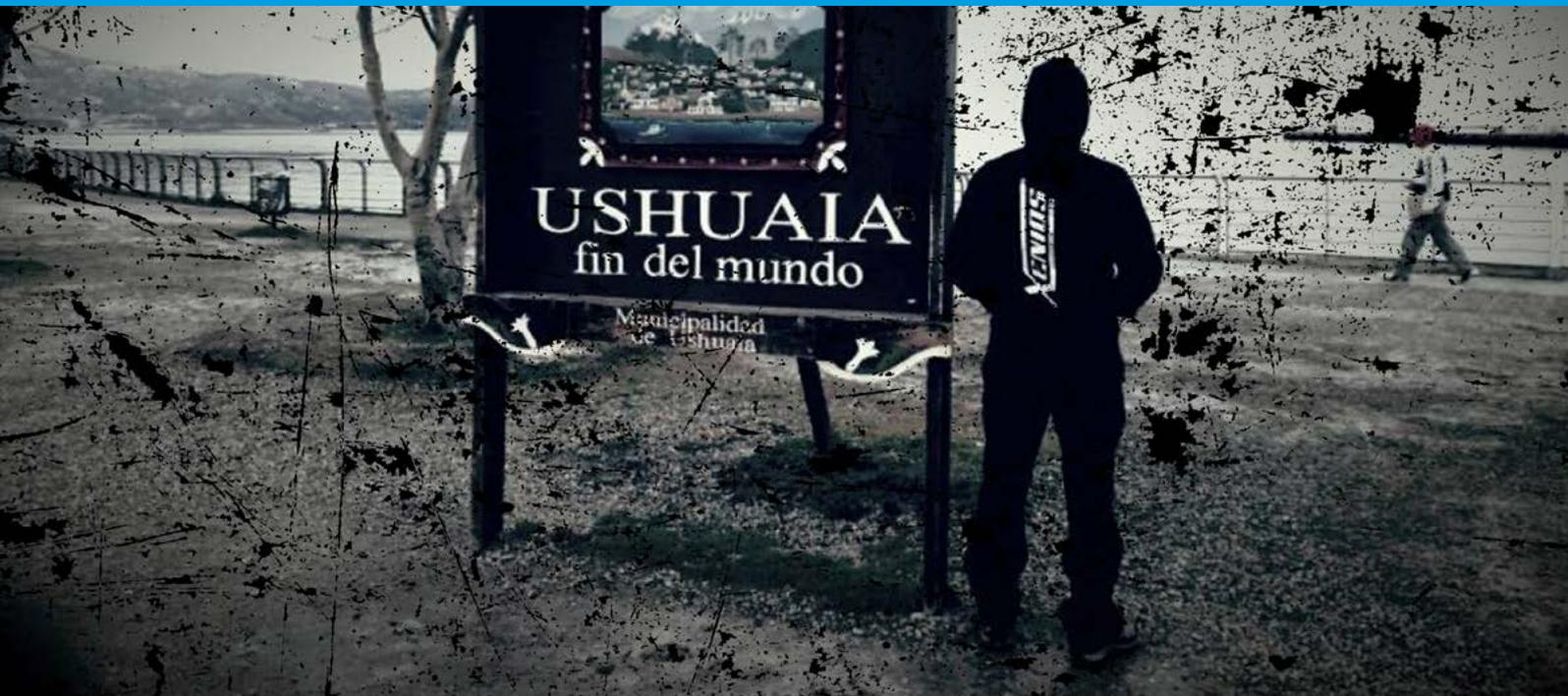

XENIOS USA WARRANTY

Thanks for choosing a Xenios USA product!

Xenios USA® products, except for what mentioned in written for some special items*, carry a limited two years warranty against breakages and damages, just for the original owner (who need to prove his status by having the original purchase document). Xenios USA® warranty's rights are not transferable. Xenios USA® warranty time-frame starts from the date of purchase of each product. As stated on to the original purchase document.

Xenios USA® products carry a limited 30 days warranty against evident by-factory manufacturing defects, for the original owner. Should any defects be present on items' delivery, due to problems occurred during shipment, evidenced by a damaged and/or mishandled packaging, warranty will be effective just if the delivery was checked and accepted by the recipient by following the goods-checking rules. The delivery and goods-checking rules sheet is always attached to the shipped parcel/s. A copy of the same can be anyway downloaded from our website: www.xeniosusa.com

Xenios USA® warranty doesn't provide to the customers any product returning right but in case of evident breakages and/or damages of the same. Any product returning policy will be stated and ruled by each Xenios USA® Dealer and/or Re-seller according to his own Country Laws and Regulations about the consumers' rights care.

Xenios USA LLC or one of its International Licensers, Agents and/or Dealers (local and/or international), in case of any warranty intervention, will repair or replace the damaged and/or broken items, previously returned by the customers, at their own, so to be inspected by Xenios USA LLC or one of his International Licensers, Agents and/or Dealers (local and/or international), in order to evaluate the validity of the warranty terms. Xenios USA LLC, its International Licensers, Agents and/or Dealers will not be bound by further purchaser's own Country laws and regulations on products' warranty, unless they are issued by the same Country from where goods are invoiced and/or shipped.

Xenios USA® products are not guaranteed against any kind of damage and/or breakage and/or consequence, resulting from an improper use and/or a misuse, and/or a mishandling, misapplication, alteration or modification, and/or abuse of them and/or a shortage of care and maintenance (Please refer also to the "Safety and Usage Guide" and "Care and Maintenance Guide" for the Xenios USA® products. Both can be downloaded from our website www.xeniosusa.com). Xenios USA® Warranty will not cover any damage occurred to properties and/or persons and/or animals, during the assembling and/or installing procedures of the Xenios USA® products (made by the users) and/or while they are used. Any Xenios USA® product carry its own User and Assembly Manual (where required by the kind of the item), along with the Warranty Card, where special warranties about the assembling, installing and use of the same product are mentioned on. The Xenios USA® products are training tools and they need to be used for such purpose. They are not a toy and so children should always use the same being looked after by adults. Xenios USA® always recommend to use any workout tools under the guide of expert trainers and just by keep being checked-up by a physician on a regular basis.

Xenios USA® warranty doesn't cover the considered standard wear consequences, (as mere example: chipping or fading out of painting and/or colors and/or chrome-finishing is considered normal wear by the use).

Xenios USA® warranty validity is always subjected to the previous inspection of the damaged and/or broken products, by Xenios USA LLC or one of his International Licensers, Agents and/or Dealers. Xenios USA® Warranty doesn't cover costs of removal and/or transportation for the Xenios USA® products sent by the customers to be inspected (just when needed).

In case of any failure or breakage of any Xenios USA® product, which may be covered under warranty, a formal warranty claim should be submitted to Xenios USA LLC, through the warranty form, at www.xeniosusa.com or directly at one of the Xenios USA® international Licensers, Agents and/or Dealers from where the product was bought.

Xenios USA LLC reserves the right to make changes on the design and/or materials and/or features and/or sizes of any Xenios USA® product, without any formal notice. Xenios USA® warranty will not cover any claim for products' specs and/or feature and/or outlook differences compare with the ones published on to any Xenios USA® marketing mean.

The here above Warranty rules are not applicable to the Dealers and Re-sellers purchases that will be ruled by the relevant Laws and regulations about wholesalers' business kind.

CARE, MAINTENANCE, SAFETY AND USAGE

All Xenios USA® products must be periodically inspected and maintained for longer lifespan, to avoid any kind of earlier wearing and to make sure products keep being safe for users. For a proper care of all the Xenios USA® products, please refer to our web site, www.xeniosusa.com, where all the care and maintenance guides can be downloaded from. Warranty will void in case of unproper care and maintenance of Xenios USA® products. Xenios USA® recommends to follow all safety and usage instructions before to use any Xenios USA® product. Safety and usage guides can be downloaded at www.xeniosusa.com. Any Xenios USA® product carry a user and assembly manual (when required by the kind of the item), along with a warranty cards. Xenios USA LLC recommends/to carefully read them before to install, assembly and use any product.

A daily basis inspection and maintenance of the Xenios USA® products will let them last longer and it will also avoid any kind of damage and/or personal injury by using them. Xenios USA LLC or his international licensers, agents and/or dealer will not be responsible for any kind of damage and/or personal injuries caused by the use of a careless or maintenance-less product.

Xenios USA® reserves the right to change product design, construction materials and specifications at any time without notice. While every effort has been made to ensure that all graphic representations and descriptions of goods available from Xenios USA® correspond to the actual goods, Xenios USA® and/or its dealers and/or its international agents are not responsible for any variations from these descriptions. Error & omissions excepted. Some of the products could not be available within all countries.





© XENIOS USA LLC – NY (USA) all rights reserved. The use and the copy of all the contents are not allowed, without the authorization of XENIOS USA LLC.

XENIOS USA® trademark and all the Registered Design Patents are owned by and used under the license from XENIOS USA LLC – NY (USA)



www.xenios.usa.com Follow Us on: **WWW.GLOBALFITNESS.ES**